

 **HONDA**

**OWNER'S MANUAL
USO E MANUTENZIONE
MANUAL DEL PROPIETARIO**



CB1300/S/A/SA

Honda CB1300/S/A/SA

OWNER'S MANUAL

USO E MANUTENZIONE

MANUAL DEL PROPIETARIO

IMPORTANT INFORMATION

- **OPERATOR AND PASSENGER**

This motorcycle is designed to carry the operator and one passenger. Never exceed the maximum weight capacity as shown on the accessories and loading label.

- **ON-ROAD USE**

This motorcycle is designed to be used only on the road.

- **READ THIS OWNER'S MANUAL CAREFULLY**

Pay special attention to the safety messages that appear throughout the manual. These messages are fully explained in the "A Few Words About Safety" section which appears before the Contents page.

This manual should be considered a permanent part of the motorcycle and should remain with the motorcycle when resold.

Honda CB1300/S/A/SA OWNER'S MANUAL

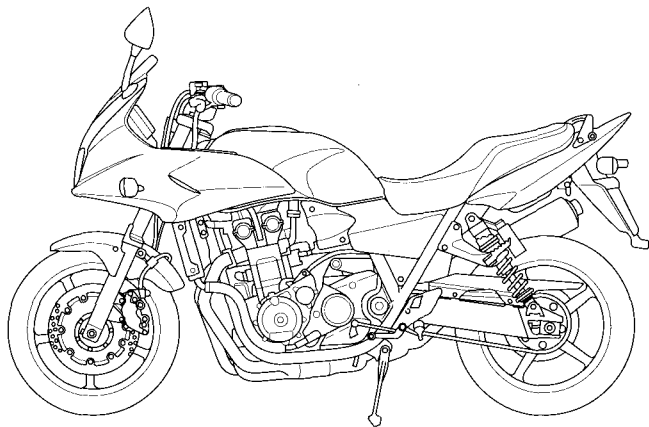

All information in this publication is based on the latest production information available at the time of approval for printing. Honda Motor Co.,Ltd. reserves the right to make changes at any time without notice and without incurring any obligation.

No part of this publication may be reproduced without written permission.

WELCOME

The motorcycle presents you a challenge to master the machine, a challenge to adventure. You ride through the wind, linked to the road by a vehicle that responds to your commands as no other does. Unlike an automobile, there is no metal cage around you. Like an airplane, a pre-ride inspection and regular maintenance are essential to your safety. Your reward is freedom.

To meet the challenges safely, and to enjoy the adventure fully, you should become thoroughly familiar with this owner's manual **BEFORE YOU RIDE THE MOTORCYCLE**.

As you read this manual, you will find information that is preceded by a **NOTICE** symbol. This information is intended to help you avoid damage to your motorcycle, other property, or the environment.

When service is required, remember that your Honda dealer knows your motorcycle best. If you have the required mechanical "know-how" and tools, your dealer can supply you with an official Honda Shop Manual to help you perform many maintenance and repair tasks.

Pleasant riding, and thank you for choosing a Honda !

- The following codes in this manual indicate each country.
- The illustrations herein are based on the CB1300SA type.

CB1300

BR	Brazil	II BR	(BR Type II)
ED	European direct sales		
U	Australia New Zealand		
SI	Singapore		

CB1300S

U	Australia New Zealand	II U	(U Type II)
---	--------------------------	------	-------------

CB1300A

BR	Brazil	II BR	(BR Type II)
F	France	VII UK	(UK Type VII)
ED	European direct sales		

CB1300SA

F	France	VIII E	(UK Type VII)
ED	European direct sales	VIII E	(UK Type VIII)
U	Australia New Zealand	III F	(F Type III)
		III ED	(ED Type III)
SI	Singapore	II U	(U Type II)
KO	Korea	II SI	(SI Type II)

- The specifications may vary with each locale.

A FEW WORDS ABOUT SAFETY

Your safety, and the safety of others, is very important. And operating this motorcycle safely is an important responsibility.

To help you make informed decisions about safety, we have provided operating procedures and other information on labels and in this manual. This information alerts you to potential hazards that could hurt you or others.

Of course, it is not practical or possible to warn you about all hazards associated with operating or maintaining a motorcycle. You must use your own good judgment.

You will find important safety information in a variety of forms, including:

- **Safety Labels** — on the motorcycle.
- **Safety Messages** — preceded by a safety alert symbol  and one of three signal words: **DANGER, WARNING, or CAUTION.**

These signal words mean:

▲ DANGER

You **WILL** be **KILLED** or **SERIOUSLY HURT** if you don't follow instructions.

▲ WARNING

You **CAN** be **KILLED** or **SERIOUSLY HURT** if you don't follow instructions.

▲ CAUTION

You **CAN** be **HURT** if you don't follow instructions.

- **Safety Headings** — such as Important Safety Reminders or Important Safety Precautions.
- **Safety Section** — such as Motorcycle Safety.
- **Instructions** — how to use this motorcycle correctly and safely.

This entire manual is filled with important safety information — please read it carefully.

OPERATION

page

1 MOTORCYCLE SAFETY

- 1 IMPORTANT SAFETY INFORMATION
- 2 PROTECTIVE APPAREL
- 4 LOAD LIMITS AND GUIDELINES

8 PARTS LOCATION

- 14 INSTRUMENTS AND INDICATORS

47 MAJOR COMPONENTS

(Information you need to operate this motorcycle)

- 47 SUSPENSION
- 52 HANDLEBAR POSITION
- 53 BRAKES
- 56 CLUTCH
- 58 COOLANT
- 61 FUEL
- 64 ENGINE OIL
- 65 TUBELESS TYRES

page

71 ESSENTIAL INDIVIDUAL COMPONENTS

- 71 IGNITION SWITCH
- 72 KEYS
- 74 IMMOBILIZER SYSTEM (HISS)
- 77 RIGHT HANDLEBAR CONTROLS
- 79 LEFT HANDLEBAR CONTROLS

page

80 FEATURES

(Not required for operation)

- 80 STEERING LOCK
- 81 SEAT
- 82 HELMET HOLDER
- 83 DOCUMENT BAG
- 84 CENTER COMPARTMENT
- 85 STORAGE COMPARTMENT FOR
U-SHAPED ANTI-THEFT LOCK
- 86 RIGHT POCKET
- 87 LEFT POCKET
- 88 SIDE COVERS
- 89 LOWER COWL
- 90 LEFT SIDE COWL
- 91 FUEL TANK MAINTENANCE
POSITION
- 93 HEADLIGHT AIM VERTICAL
ADJUSTMENT
- 94 CLIP

page

96 OPERATION

- 96 PRE-RIDE INSPECTION
- 98 STARTING THE ENGINE
- 102 RUNNING-IN
- 103 RIDING
- 105 BRAKING
- 108 PARKING
- 109 ANTI-THEFT TIPS

MAINTENANCE

page		page	
110	MAINTENANCE	150	BRAKE PAD WEAR
110	THE IMPORTANCE OF MAINTENANCE	152	BATTERY
111	MAINTENANCE SAFETY	155	FUSE REPLACEMENT
112	SAFETY PRECAUTIONS	158	BRAKELIGHT SWITCH ADJUSTMENT
113	MAINTENANCE SCHEDULE	159	BULB REPLACEMENT
116	TOOL KIT		
117	SERIAL NUMBERS	166	CLEANING
118	COLOUR LABEL (Except BR type)	170	STORAGE GUIDE
119	ENGINE OIL	170	STORAGE
126	CRANKCASE BREATHERS	172	REMOVAL FROM STORAGE
128	SPARK PLUGS		
131	THROTTLE OPERATION	173	TAKING CARE OF THE UNEXPECTED
132	COOLANT		
133	AIR CLEANER	174	SPECIFICATIONS
134	DRIVE CHAIN		
141	DRIVE CHAIN SLIDER	178	CATALYTIC CONVERTERS
142	FRONT AND REAR SUSPENSION INSPECTION		
143	SIDE STAND		
144	WHEEL REMOVAL		

MOTORCYCLE SAFETY

IMPORTANT SAFETY INFORMATION

Your motorcycle can provide many years of service and pleasure – if you take responsibility for your own safety and understand the challenges that you can meet on the road.

There is much that you can do to protect yourself when you ride. You'll find many helpful recommendations throughout this manual. Following are a few that we consider to be most important.

Always Wear a Helmet

It's a proven fact: helmets significantly reduce the number and severity of head injuries. So always wear an approved motorcycle helmet and make sure your passenger does the same. We also recommend that you wear eye protection, sturdy boots, gloves, and other protective gear (page 2).

Make Yourself Easy to See

Some drivers do not see motorcycles because they are not looking for them. To make yourself more visible, wear bright reflective clothing, position yourself so other drivers can see you, signal before turning or changing lanes, and use your horn when it will help others notice you.

Ride Within Your Limits

Pushing the limits is another major cause of motorcycle accidents. Never ride beyond your personal abilities or faster than conditions warrant. Remember that alcohol, drugs, fatigue and inattention can significantly reduce your ability to make good judgements and ride safely.

Don't Drink and Ride

Alcohol and riding don't mix. Even one drink can reduce your ability to respond to changing conditions, and your reaction time gets worse with every additional drink. So don't drink and ride, and don't let your friends drink and ride either.

Keep Your Bike in Safe Condition

For safe riding, it's important to inspect your motorcycle before every ride and perform all recommended maintenance. Never exceed load limits, and only use accessories that have been approved by Honda for this motorcycle. See page 4 for more details.

PROTECTIVE APPAREL

For your safety, we strongly recommend that you always wear an approved motorcycle helmet, eye protection, boots, gloves, long pants, and a long-sleeved shirt or jacket whenever you ride. Although complete protection is not possible, wearing proper gear can reduce the chance of injury when you ride.

Following are suggestions to help you choose proper gear.

WARNING

Not wearing a helmet increases the chance of serious injury or death in a crash.

Be sure you and your passenger always wear a helmet, eye protection and other protective apparel when you ride.

Helmets and Eye Protection

Your helmet is your most important piece of riding gear because it offers the best protection against head injuries. A helmet should fit your head comfortably and securely. A bright-coloured helmet can make you more noticeable in traffic, as can reflective strips.

An open-face helmet offers some protection, but a full-face helmet offers more. Always wear a face shield or goggles to protect your eyes and help your vision.

Additional Riding Gear

In addition to a helmet and eye protection, we also recommend:

- Sturdy boots with non-slip soles to help protect your feet and ankles.
- Leather gloves to keep your hands warm and help prevent blisters, cuts, burns and bruises.
- A motorcycle riding suit or jacket for comfort as well as protection. Bright-coloured and reflective clothing can help make you more noticeable in traffic. Be sure to avoid loose clothes that could get caught on any part of your motorcycle.

LOAD LIMITS AND GUIDELINES

Your motorcycle has been designed to carry you and one passenger. When you carry a passenger, you may feel some difference during acceleration and braking. But so long as you keep your motorcycle well-maintained, with good tyres and brakes, you can safely carry loads within the given limits and guidelines.

However, exceeding the weight limit or carrying an unbalanced load can seriously affect your motorcycle's handling, braking and stability. Non-Honda accessories, improper modifications, and poor maintenance can also reduce your safety margin.

The following pages give more specific information on loading, accessories and modifications.

Loading

How much weight you put on your motorcycle, and how you load it, are important to your safety. Anytime you ride with a passenger or cargo you should be aware of the following information.

WARNING

Overloading or improper loading can cause a crash and you can be seriously hurt or killed.

Follow all load limits and other loading guidelines in this manual.

Load Limits

Following are the load limits for your motorcycle:

Maximum weight capacity:

188 kg (415 lbs)

Includes the weight of the rider, passenger, all cargo and all accessories

Maximum cargo weight:

27 kg (60 lbs)

CB1300S/SA

Putting too much weight in individual storage compartments can also affect stability and handling. So be sure to stay within the limits given below:

Maximum weight:

in right pocket

0.5 kg (1.0 lbs)

in left pocket

0.5 kg (1.0 lbs)

The weight of added accessories will reduce the maximum cargo weight you can carry.

Loading Guidelines

Your motorcycle is primarily intended for transporting you and a passenger. You may wish to secure a jacket or other small items to the seat when you are not riding with a passenger.

If you wish to carry more cargo, check with your Honda dealer for advice, and be sure to read the information regarding accessories on page 6.

Improperly loading your motorcycle can affect its stability and handling. Even if your motorcycle is properly loaded, you should ride at reduced speeds and never exceed 130 km/h (80 mph) when carrying cargo.

Follow these guidelines whenever you carry a passenger or cargo:

- Check that both tyres are properly inflated (page 65).
- If you change your normal load, you may need to adjust the front suspension (page 47) and the rear suspension (page 49).
- To prevent loose items from creating a hazard, make sure that all cargo is securely tied down before you ride away.
- Place cargo weight as close to the center of the motorcycle as possible.
- Balance cargo weight evenly on both sides.

Accessories and Modifications

Modifying your motorcycle or using non-Honda accessories can make your motorcycle unsafe. Before you consider making any modifications or adding an accessory, be sure to read the following information.

WARNING

Improper accessories or modifications can cause a crash in which you can be seriously hurt or killed.

Follow all instructions in this owner's manual regarding accessories and modifications.

Accessories

We strongly recommend that you use only Honda Genuine Accessories that have been specifically designed and tested for your motorcycle. Because Honda cannot test all other accessories, you must be personally responsible for proper selection, installation and use of non-Honda accessories. Check with your dealer for assistance and always follow these guidelines:

- Make sure the accessory does not obscure any lights, reduce ground clearance and banking angle, limit suspension travel or steering travel, alter your riding position or interfere with operating any controls.
- Be sure electrical equipment does not exceed the motorcycle's electrical system capacity (page 177). A blown fuse can cause a loss of lights or engine power.

- Do not pull a trailer or sidecar with your motorcycle. This motorcycle was not designed for these attachments, and their use can seriously impair your motorcycle's handling.

Modifications

We strongly advise you not to remove any original equipment or modify your motorcycle in any way that would change its design or operation. Such changes could seriously impair your motorcycle's handling, stability and braking, making it unsafe to ride.

Removing or modifying your lights, mufflers, emission control system or other equipment can also make your motorcycle illegal.

PARTS LOCATION

CB1300S/SA

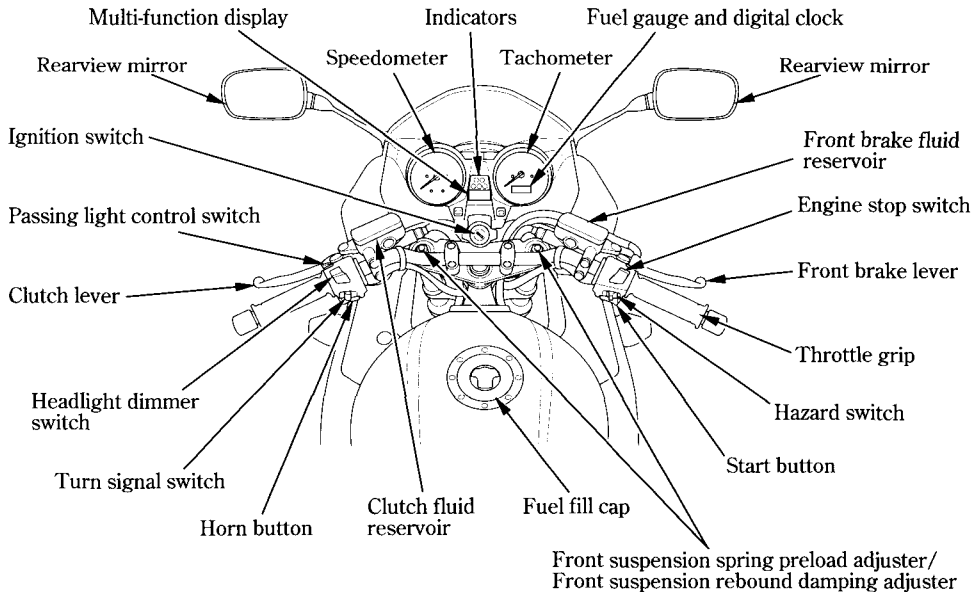

CB1300/A

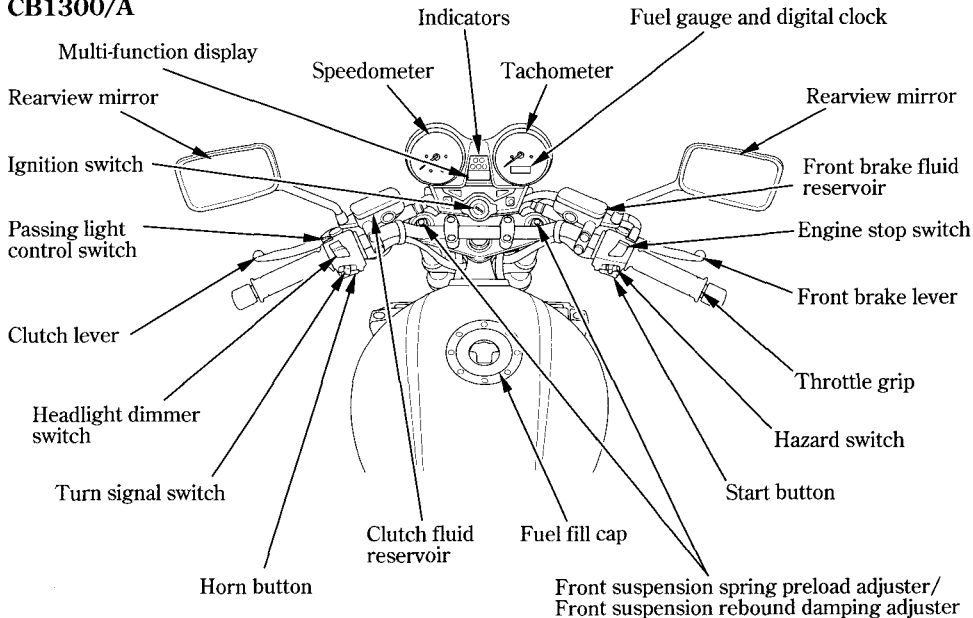

CB1300S/SA

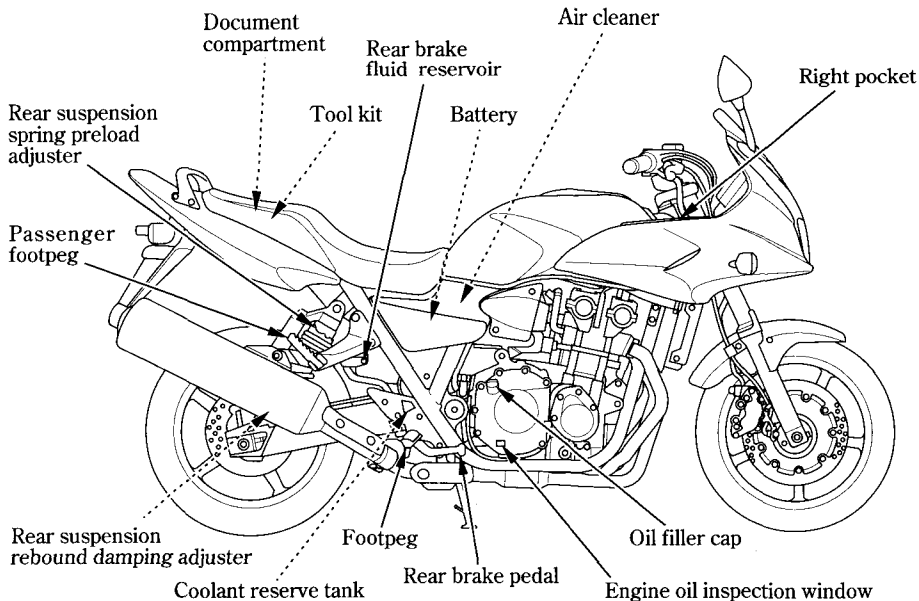

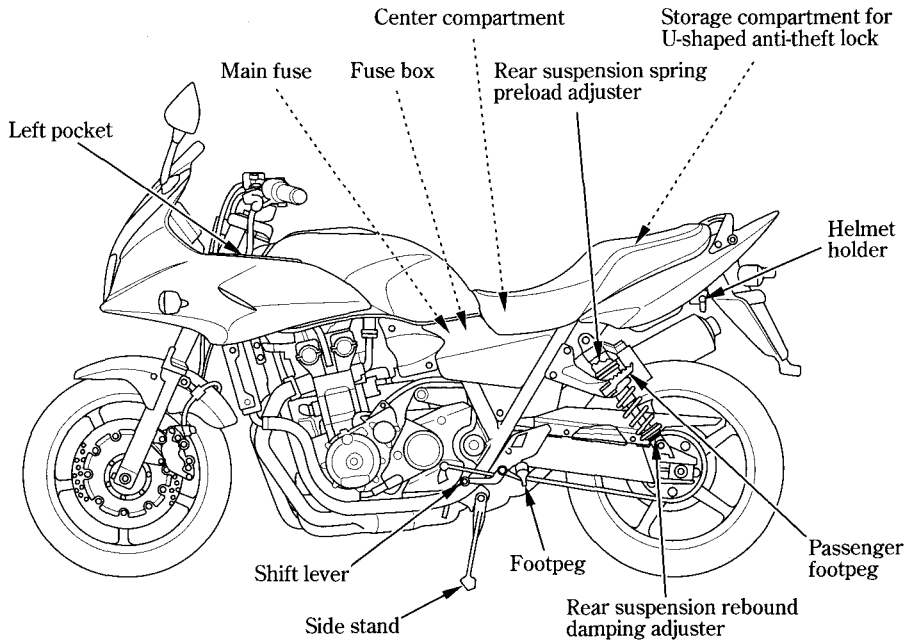

CB1300/A

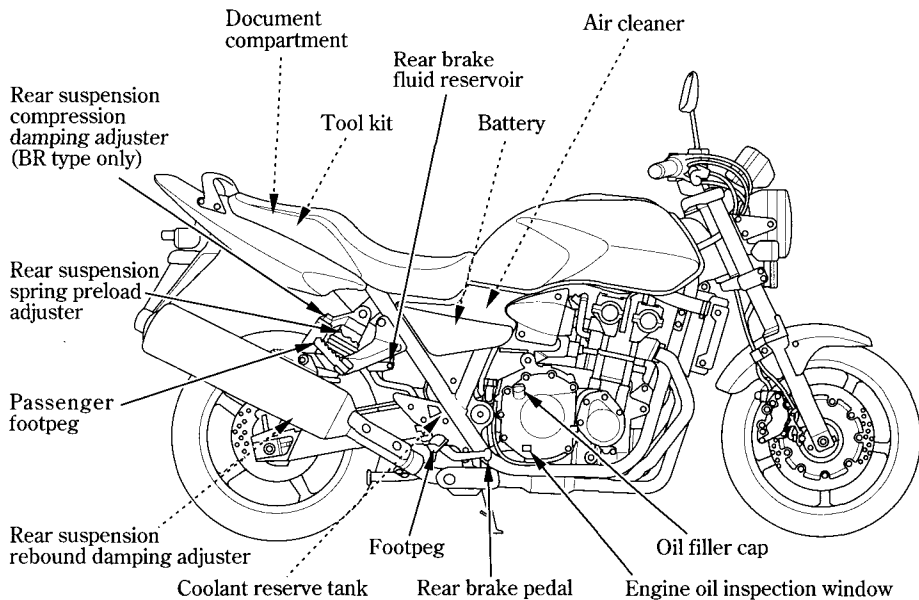

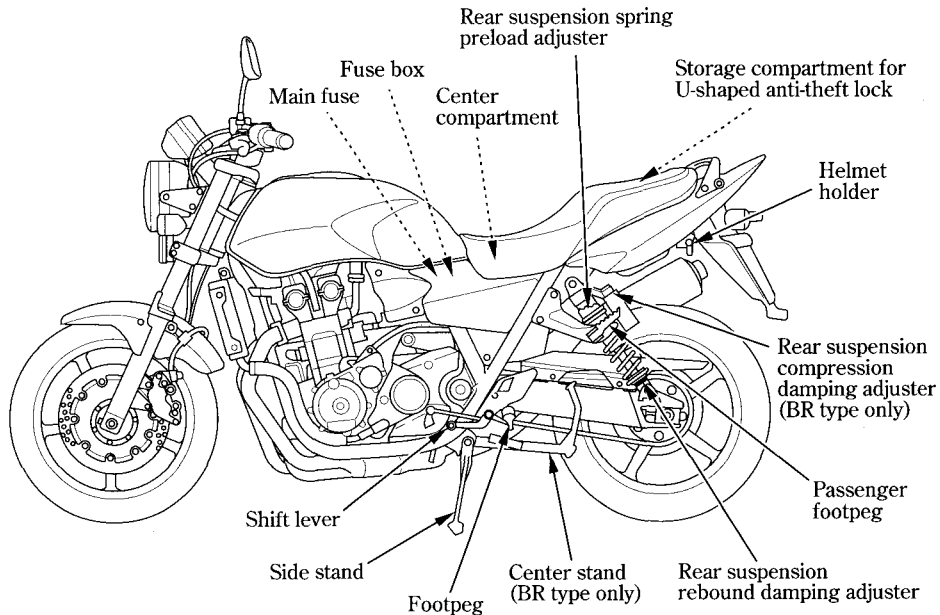

INSTRUMENTS AND INDICATORS CB1300S/SA

The indicators are contained in the instrument panel. Their functions are described in the tables on the following pages.

- (1) Tachometer
- (2) Tachometer red zone
- (3) Fuel gauge and digital clock
- (4) Right turn signal indicator
- (5) Right control button
- (6) Left turn signal indicator
- (7) Left control button
- (8) Multi-function display
- (9) Immobilizer system (HISS) indicator
- (10) Anti-lock Brake System (ABS) indicator (CB1300SA)
- (11) Speedometer
- (12) PGM-FI malfunction indicator lamp (MIL)
- (13) Low oil pressure indicator
- (14) Neutral indicator

- (15) High beam indicator
- (16) High coolant temperature indicator

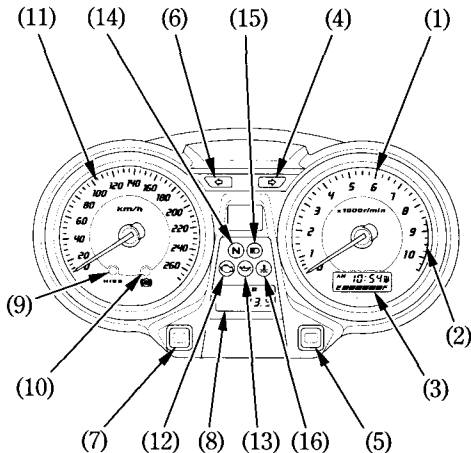

CB1300/A

- (1) Tachometer
- (2) Tachometer red zone
- (3) Fuel gauge and digital clock
- (4) Right turn signal indicator
- (5) Right control button
- (6) Left turn signal indicator
- (7) Left control button
- (8) Multi-function display
- (9) Immobilizer system (HISS) indicator
- (10) Anti-lock Brake System (ABS) indicator (CB1300A)
- (11) Speedometer
- (12) PGM-FI malfunction indicator lamp (MIL)
- (13) Low oil pressure indicator
- (14) Neutral indicator
- (15) High beam indicator
- (16) High coolant temperature indicator

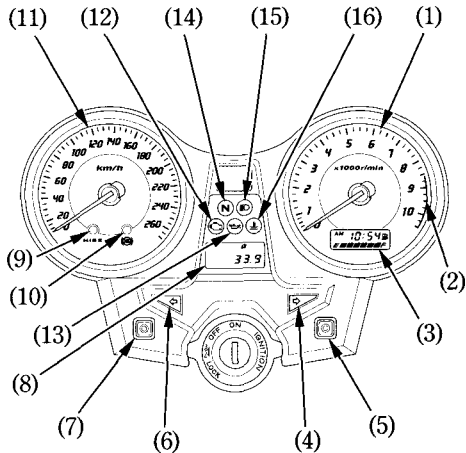



(Ref.No.) Description	Function
(1) Tachometer	Shows engine revolutions per minute. The tachometer needle will swing to the maximum scale on the dial once when the ignition switch is turned ON.
(2) Tachometer red zone	Never allow the tachometer needle to enter the red zone, even after the engine has been broken in. NOTICE Running the engine beyond recommended maximum engine speed (the beginning of the tachometer red zone) can damage the engine.
(3) Fuel gauge and digital clock	Shows approximate fuel supply available (page 43). Shows hour and minute (page 45).
(4) Right turn signal indicator (green)	Flashes when the right turn signal operates.

(Ref.No.) Description	Function
(5) Right control button	Use this button for the following purposes. <ul style="list-style-type: none"> ● To select display mode ● To set the scheduled date ● To start and pause the stopwatch ● To set mileage countdown ● To adjust time
(6) Left turn signal indicator (green)	Flashes when the left turn signal operates.
(7) Left control button	Use this button for the following purposes. <ul style="list-style-type: none"> ● To select display mode ● To reset tripmeter ● To set the scheduled date ● To reset the stopwatch ● To set mileage countdown ● To adjust time ● To switch blinking of the immobilizer system (HISS) indicator

(Ref.No.) Description	Function
(8) Multi-function display (Display mode 1)	The display includes the following functions; This display shows the initial display (page 24).
Odometer	Shows accumulated mileage (page 26).
Tripmeter 1 and 2	Shows mileage per trip (page 26).
Air temperature meter	Shows air temperature (page 28).
Coolant temperature meter	Shows coolant temperature (page 29).

(Ref.No.) Description	Function
(8) Multi-function display (Display mode 2)	The display includes the following functions; This display shows the initial display (page 24).
DAYS	Shows scheduled date (page 32).
Stopwatch	Shows stopwatch (page 35).
Mileage Countdown	Shows subtraction mileage (page 37).
TODAY	Shows the current days and mileage (page 40).

(Ref.No.) Description	Function
<p>(9) Immobilizer system (HISS) indicator (red)</p>	<p>This indicator lights for a few seconds when the ignition switch is turned ON and the engine stop switch is at  (RUN). It will then go off if the properly-coded key has been inserted. If an improperly-coded key has been inserted, the indicator will remain on and the engine will not start (page 74).</p> <p>When the blinking function of this indicator is valid and the ignition switch is OFF, it keeps blinking for 24 hours (page 74).</p>
<p>(10) Anti-lock Brake System (ABS) indicator (amber) (CB1300A/SA)</p>	<p>This indicator normally comes on when the ignition switch is turned ON, and goes off after you ride the motorcycle at speed above 10 km/h (6 mph). If there is a problem with the Anti-lock Brake System, this indicator flashes and remains on (page 107).</p>

(Ref.No.) Description	Function
(11) Speedometer	<p>Shows riding speed.</p> <p>This shows your speed in kilometers per hour (km/h) and/or miles per hour (mph) depending on the type.</p> <p>The speedometer needle will swing to the maximum scale on the dial once when the ignition switch is turned ON.</p>
(12) PGM-FI malfunction indicator lamp (MIL) (amber)	<p>Lights when there is any abnormality in the PGM-FI (Programmed Fuel Injection) system. Should also light for a few seconds and then go off when the ignition switch is turned ON and engine stop switch is at  (RUN).</p> <p>If it comes on at any other time, reduce speed and take the motorcycle to your Honda dealer as soon as possible.</p>

(Ref.No.) Description	Function
(13) Low oil pressure indicator (red)	<p>Lights when the engine oil pressure is below normal operating range. Should light when ignition switch is ON and engine is not running. Should go out when the engine starts, except for occasional flickering at or near idling speed when engine is warm.</p> <p>NOTICE</p> <p>Running the engine with insufficient oil pressure may cause serious engine damage.</p>
(14) Neutral indicator (green)	Lights when the transmission is in neutral.
(15) High beam indicator (blue)	Lights when the headlight is on high beam.

(Ref.No.) Description	Function
(16) High coolant temperature indicator (red)	<p>Lights when the coolant is over the specified temperature. If the indicator goes on while riding, stop the engine and check the reserve tank coolant level. Read pages 58 – 60 and do not ride the motorcycle until the problem has been corrected.</p> <p>NOTICE</p> <p>Exceeding maximum running temperature may cause serious engine damage.</p>

Initial Display

When the ignition switch is turned ON, the display will temporarily show all the modes and digital segments so you can make sure the liquid crystal display is functioning properly. (Except digital clock)

The digital clock, tripmeter, DAYS and TODAY will reset if the battery is disconnected.

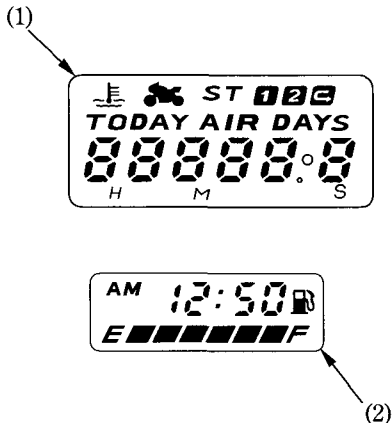

- (1) Multi-function display
- (2) Fuel gauge and digital clock

Multi-function Display

There are two display modes: display mode 1 and display mode 2.

Multi-function display mode 1 includes the following functions:

Odometer

Tripmeter

Air temperature meter

Coolant temperature meter

Multi-function display mode 2 includes the following functions:

DAYS

Stopwatch

Mileage countdown

TODAY

To switch between the display mode 1 and display mode 2, while press and hold the left control button (2), then press and hold the right control button (3) for more than 2 seconds.

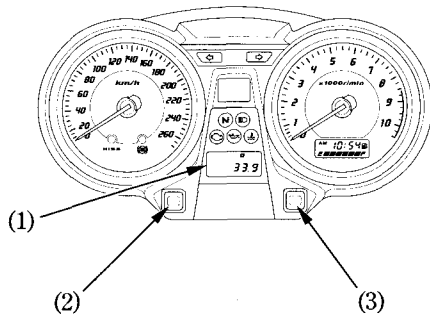

- (1) Multi-function display
- (2) Left control button
- (3) Right control button

Odometer/Tripmeter/Air Temperature Meter/Coolant Temperature Meter (display mode 1)

The display mode 1 has four functions: Odometer, Tripmeter, Air temperature meter and Coolant temperature.

Press the left control button (1) to select “ODO” (Odometer), “TRIP 1” (Tripmeter 1), “TRIP 2” (Tripmeter 2), “Air temperature meter” and “TEMP” (Coolant temperature) mode.

ED/F/U/BR/SI types: Odometer and tripmeter read in kilometers.

E type: Odometer and tripmeter read in miles.

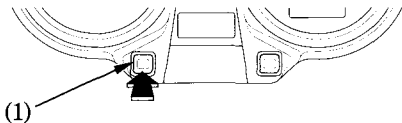

(1) Left control button

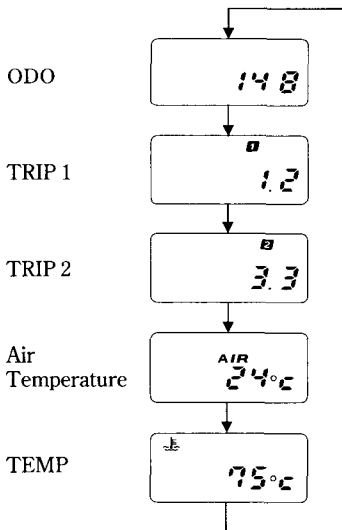

To reset the tripmeter, press and hold the left control button for more than 2 seconds when the display is in the "TRIP 1" or "TRIP 2" mode.

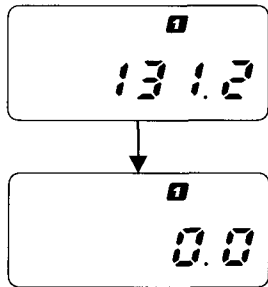

Air Temperature Meter

Air temperature meter (1) shows air temperature digitally.

To select the air temperature mode, push the left control button (2).

Temperature Display

Below -10°C	“— —” is displayed.
Between -10°C and 50°C	Actual air temperature is indicated.
Above 50°C	The display will remain and blink “ 50°C ”.

The temperature sensor is located in the meter. Therefore, the temperature reading can be affected by heat reflection from the road surface, engine heat, and the exhaust from the surrounding traffic. This can cause the temperature reading not to be correct when your speed is under 30 km/h (19 mph).

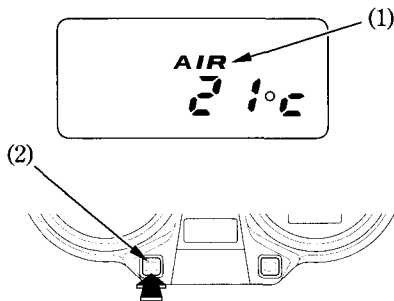

- (1) Air temperature meter
- (2) Left control button

Coolant Temperature Meter

The coolant temperature meter (1) shows coolant temperature digitally.

Temperature Display

Below 34°C	“— —” is displayed.
Between 35°C and 121°C	Actual coolant temperature is indicated.
Between 122°C and 131°C	Actual coolant temperature is indicated and flashed.
Above 132°C	The display will remain on and flash “132°C”.

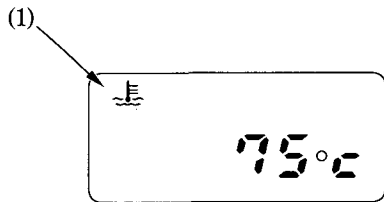

(1) Coolant temperature meter

Overheating Message

When the coolant temperature reaches 122°C , the temperature begins to flash and high coolant temperature indicator (2) flashes.

If this occurs, stop the engine and check the reserve tank coolant level. Read pages 58 – 60 and do not ride the motorcycle until the problem has been corrected.

NOTICE

Exceeding maximum running temperature may cause serious engine damage.

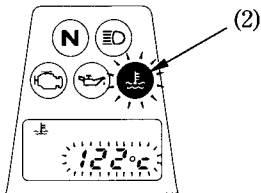

(2) High coolant temperature indicator

DAYS/Stopwatch/Mileage Countdown/ TODAY (display mode 2)

The display mode 2 has four functions:
DAYS, Stopwatch, Mileage countdown and
TODAY.

Push the left control button (1) to select
“DAYS”, “Stopwatch”, “Mileage countdown”
and “TODAY”.

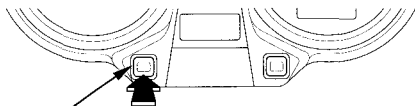

(1)

(1) Left control button

DAYS

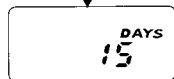

Stopwatch



Mileage
countdown

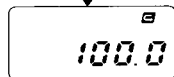

TODAY

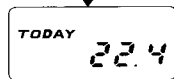

DAYS

DAYS allows you to countdown to a scheduled date in the future.

There are three display mode,

Until the scheduled date:

- The days until the scheduled date is displayed.

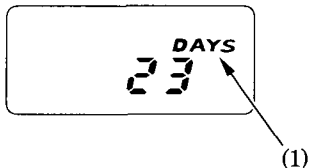

- (1) DAYS display
(2) Icon mark

Scheduled date or passed the scheduled date:

- "0" is displayed and Icon mark (2) will light.

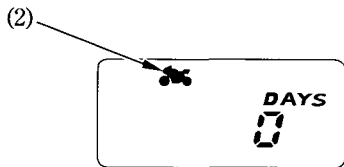

No setting:

- " - - - - - " is displayed.

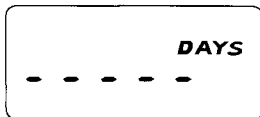

To set scheduled date:

1. Turn the ignition switch ON.
2. Select the DAYS mode.
3. Press the left control button (1) for more than 2 seconds. The display will be set in the adjustment mode with the year display flashing.

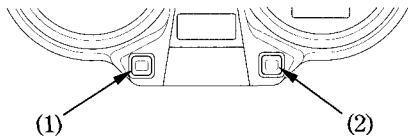
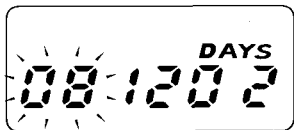

- (1) Left control button
- (2) Right control button

4. To set the year, press the right control button (2) until the desired year appears.
 - Quick setting – press and hold the right control button until the desired year appears.
 - If setting “-” while adjusting year, scheduled date is not set.
5. Press the left control button when the display reaches the desired year. The month display will be flashing.



6. Repeat steps 4 and 5 for the month and day.

If the ignition switch is turned off or no operation is performed for 5 seconds during the adjustment mode, the set date will reset.

When the battery terminal is disconnected:

- If the scheduled date has been set, "0" will be flashing and the Icon mark will be lit until the present date is set (page 40).
- If the scheduled date is not set, " - - - - - " will be displayed.

Stopwatch

The stopwatch will count hours, minutes and seconds.

Stopwatch measurement range:

After measuring 9 hours, 59 minutes, 59.9 seconds, it returns to 0 hours, 0 minutes, 00.0 seconds and will continue counting.

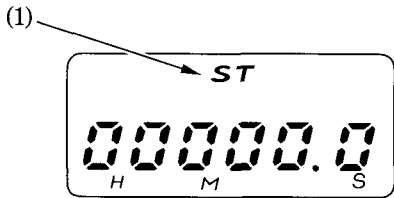

- (1) Stopwatch display
- (2) Right control button

How to measure time:

1. Turn the ignition switch ON.
2. Select the stopwatch mode.
3. To measure, push the right control button (2). While measuring, push the right control button to pause and push it again to resume.

START

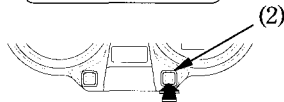

PAUSE

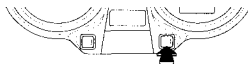

Stopwatch RESET:

Press and hold the left control button (1) for more than 2 seconds when the stopwatch is paused.

PAUSE

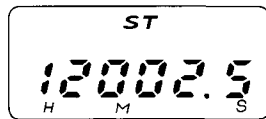

RESET

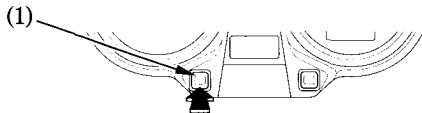

(1) Left control button

Mileage Countdown

In this mode, the mileage will be subtracted from the preset figure. When the mileage exceeds the preset figure, the numeric will flash.



How to set distance:

1. Turn the ignition switch ON.
2. Select the mileage countdown mode.
3. Press and hold the left control button (2) for more than 2 seconds.
 - Display will change to the set distance mode or reset to the initial setting. See following Example page.

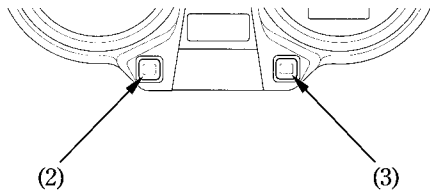

- (1) Mileage countdown display
- (2) Left control button
- (3) Right control button

Example

- If you set the subtraction trip mode and do not travel, you will have to re-enter the trip distance.
- If you set the subtraction trip mode and do not complete the set distance, the subtraction trip mode will reset to the initial setting.

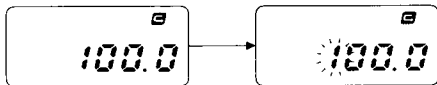

Change to the set distance mode.

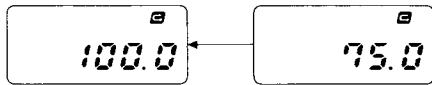

Reset to the initial setting.

4. The preset figure is displayed and the third digit will be flashing.



5. To set the third digit, press the right control button (3) until the desired third digit appears.

- Quick setting – press and hold the right control button until the desired third digit appears.

6. Press the left control button when the display reaches the desired figure. The second digit will be flashing.



7. Repeat steps 5 and 6 for the second and first digits.

If the ignition switch is turned off or no operation is performed for 5 seconds during the adjustment mode, the set digits will reset.

TODAY

Shows the present date for 5 seconds and then shows today's mileage.

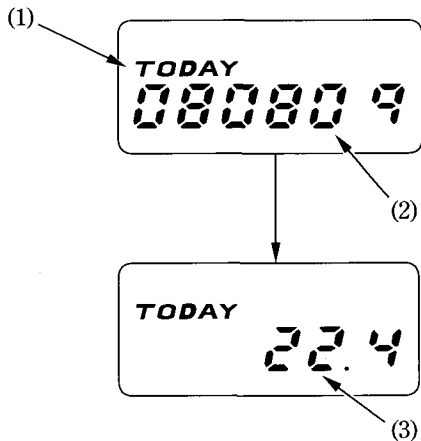

- (1) TODAY display
- (2) Present date
- (3) Today's mileage

How to set date:

1. Turn the ignition switch ON.
2. Select the TODAY mode.
3. During the present date display displayed (for 5 seconds), press and hold the right control button (4) for more than 2 seconds.

The year display will be flashing.

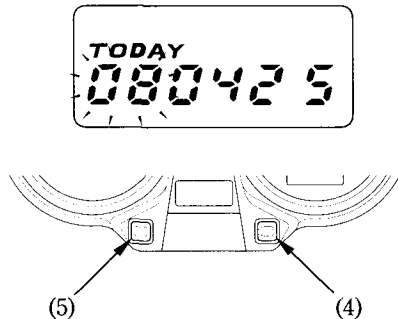

- (4) Right control button
- (5) Left control button

- To set the year, press the right control button until the desired year appears.
 - Quick setting — press and hold the right control button until the desired year appears.
- Press the left control button (5) when the display reaches the desired year. The month display will be flashing.

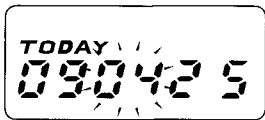

- Repeat steps 4 and 5 for the month and day.

- After finishing the data setting, change over to digital clock setting mode. To set the digital clock. See page 45 .

If the ignition switch is turned off or no operation is performed for 5 seconds during the adjustment mode, the set date will reset.

The present date will reset to "000101" if the battery terminal is disconnected.

Fuel Gauge and Digital Clock

The fuel gauge and digital clock display (1) includes the fuel gauge liquid crystal display (2) and the digital clock (3).

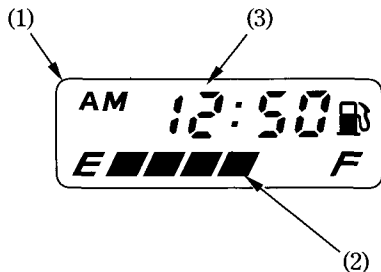

- (1) Fuel gauge and digital clock display
- (2) Fuel gauge liquid crystal display
- (3) Digital clock

Fuel Gauge

The fuel gauge liquid crystal display (1) shows the approximate fuel supply available in a graduated display. When the segment F (2) goes on, the fuel tank capacity including reserve is:

21.0 l (5.55 US gal , 4.62 Imp gal)

When the display flashes as shown in the illustration, fuel will be low and you should refill the tank as soon as possible.

The amount of fuel left in the tank with the vehicle set upright is approximately:

4.0 l (1.06 US gal , 0.88 Imp gal)

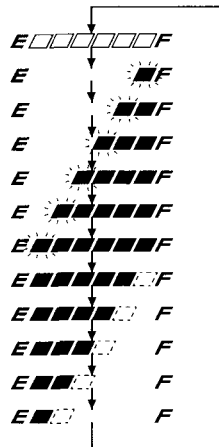
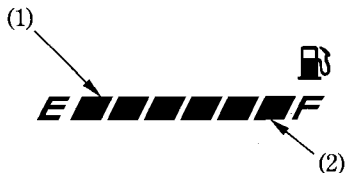

- (1) Fuel gauge liquid crystal display
- (2) Segment F

Fuel Gauge Failure Indication:

If the fuel system has an error, the fuel gauge indicators will be displayed as shown in the illustration.

If this occurs, see your Honda dealer as soon as possible.

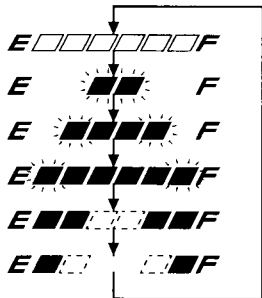

Digital Clock

The digital clock will show hours and minutes up to 11:59 with “AM” and “PM”.

To adjust the time, proceed as follows:

1. Turn the ignition switch ON.
2. Press and hold the right control button (1) for more than 2 seconds. The clock will be set in the adjust mode with the hour flashing.
 - When TODAY present date or Stopwatch is displayed, adjust mode can not be selected.

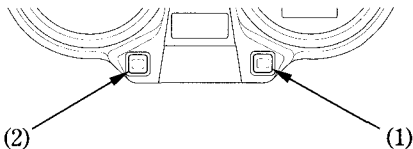

- (1) Right control button
(2) Left control button



3. To set the hour, press the right control button until the desired hour and AM/PM are displayed.
 - Quick setting – press and hold the right control button until the desired hour appears.
4. Press the left control button (2) when the display reaches the desired hour. The minute display will be flashing.

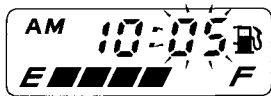

5. To set the minute, press the right control button until the desired minute appears.
 - Quick setting – press and hold the right control button until the desired minute appears.
6. Press the left control button when the display reaches the desired minute.
The display will stop flashing.

If the ignition switch is turned off or no operation is performed for 5 seconds during the time adjustment mode, the clock will be reset.

The clock will be reset AM 1:00 if the battery is disconnected.

MAJOR COMPONENTS

(Information you need to operate this motorcycle)

SUSPENSION

Front Suspension

Spring Preload:

Adjust the spring preload by turning the preload adjuster (1) with the 14 × 17 mm wrench provided in the tool kit (page 116).

Make sure that both fork legs are adjusted to the same position.

To reduce (SOFT) :

Turn the adjuster counterclockwise toward SOFT for a light load and smooth road condition.

To increase (HARD) :

Turn the adjuster clockwise toward HARD for a firmer ride and rough road condition.

Standard Position:

To return to the standard position, turn the adjusters until the fourth groove from the top aligns with the top surface of the fork caps.

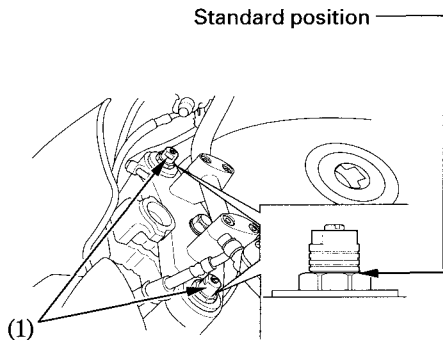

(1) Preload adjuster

Rebound Damping:

To reduce (SOFT) :

Turn the adjuster counterclockwise toward SOFT (S) for a light load and smooth road condition.

To increase (HARD) :

Turn the adjuster clockwise toward HARD (H) for a firmer ride and rough road condition.

To adjust the adjuster to the standard position, proceed as follows :

1. Turn the damping adjuster (1) clockwise until it will no longer turn (lightly seats). This is the full hard setting.
2. The adjuster is set in the standard position when the adjuster is turned counterclockwise approximately 1 1/2 turns so that its punch mark (2) aligns with the reference mark (3).
3. Make sure that both fork legs are adjusted to the same position.

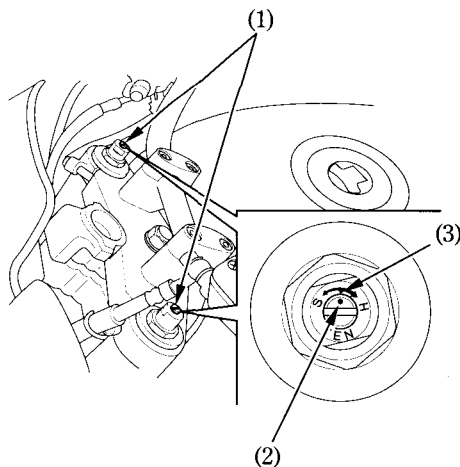

(1) Damping adjuster

(2) Punch mark

(3) Reference mark

Rear Suspension

Rebound Damping:

To reduce (SOFT) :

Turn the adjuster toward SOFT (S) for a light load and smooth road condition.

To increase (HARD) :

Turn the adjuster toward HARD (H) for a firmer ride and rough road condition.

To adjust the adjuster to the standard position, proceed as follows :

1. Turn the damping adjuster (1) toward HARD until it will no longer turn. This is the full hard setting.
2. The adjuster is set in the standard position when the adjuster is turned toward SOFT 10 clicks.
3. Make sure that both shock absorbers are adjusted to the same position.

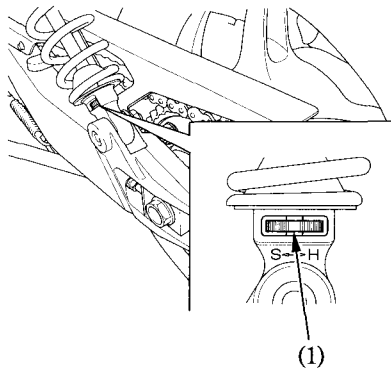

(1) Damping adjuster

Compression Damping:

(BR type only)

The damping adjuster (1) has 4 positions. Align the position numbers (2) on the adjuster dial with the index mark (3).

Position 2 is the standard position.

To reduce the damping (position 1):

Turn the adjuster counterclockwise toward position 1 for a light load and smooth road condition.

To increase the damping (positions 3 and 4):

Turn the adjuster clockwise toward position 3 and 4 for a firmer ride and rough road conditions.

Make sure that both shock absorbers are adjusted to the same position.

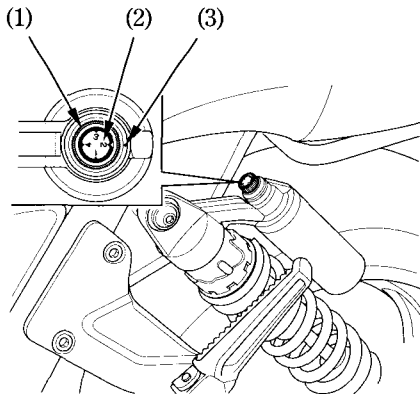

- (1) Damping adjuster
- (2) Position number
- (3) Index mark

Spring Preload:

Each shock absorber (1) has 5 adjustment positions for different load or riding conditions.

Use a pin spanner (2) and extension bar (3) to adjust the rear shocks.

Always adjust the shock absorber position in sequence (1-2-3-4-5 or 5-4-3-2-1).

Attempting to adjust directly from 1 to 5 or 5 to 1 may damage the shock absorber.

Position 1 is for light loads and smooth road conditions. Positions 3 to 5 increase spring preload for a stiffer rear suspension, and can be used when the motorcycle is heavily loaded. Be certain to adjust both shock absorbers to the same position.

Standard position: 2

The rear shock absorber assembly includes a damper unit that contains high pressure nitrogen gas. Do not attempt to disassemble or service the damper; it cannot be rebuilt and must be replaced when worn out. Disposal should only be done by your Honda dealer. The instructions found in this owner's manual are limited to adjustment of

the shock assembly only.

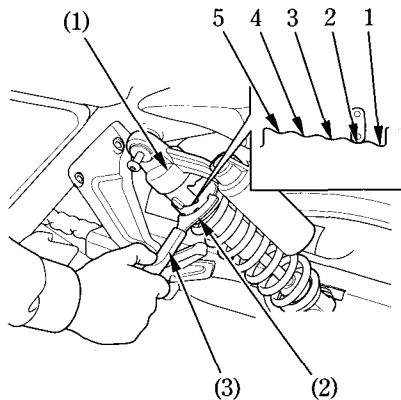

- (1) Shock absorber
- (2) Pin spanner

- (3) Extension bar

HANDLEBAR POSITION

CB1300/A

The handlebar position can be adjusted according to rider preference.

It should be serviced by your Honda dealer.

BRAKES

Both the front and rear brakes are the hydraulic disc types.

As the brake pads wear, the brake fluid level drops.

There are no adjustments to perform, but fluid level and pad wear must be inspected periodically. The system must be inspected frequently to ensure there are no fluid leaks. If the control lever or pedal free travel becomes excessive and the brake pads are not worn beyond the recommended limit (page 150), there is probably air in the brake system and it must be bled. See your Honda dealer for this service.

Front Brake Fluid Level:

With the motorcycle in an upright position, check the fluid level. It should be above the LOWER level mark (1). If the level is at or below the LOWER level mark (1), check the brake pads for wear (page 150).

Worn pads should be replaced. If the pads are not worn, have your brake system inspected for leaks.

The recommended brake fluid is Honda DOT 4 brake fluid from a sealed container, or an equivalent.

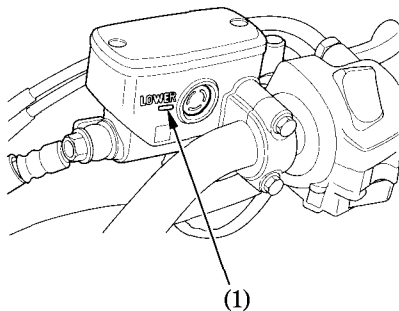

(1) LOWER level mark

Front Brake Lever:

The distance between the tip of the brake lever (1) and the grip can be adjusted by turning the adjuster dial (2) while pushing the lever forward.

Align the numbers (3) on the adjuster dial with the index mark (4).

Apply the brake several times and check for free wheel rotation after the brake lever is released.

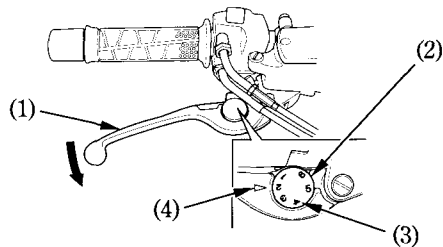

- (1) Brake lever
- (2) Adjuster dial

- (3) Numbers
- (4) Index mark

Other Checks:

Make sure there are no fluid leaks. Check for deterioration or cracks in the hoses and fittings.

Rear Brake Fluid Level:

With the motorcycle in an upright position, check the fluid level. It should be between the UPPER (1) and LOWER (2) level marks. If the level is at or below the LOWER level mark (2), check the brake pads for wear (page 151).

Worn pads should be replaced. If the pads are not worn, have your brake system inspected for leaks.

The recommended brake fluid is Honda DOT 4 brake fluid from a sealed container, or an equivalent.

Other Checks:

Make sure there are no fluid leaks. Check for deterioration or cracks in the hoses and fittings.

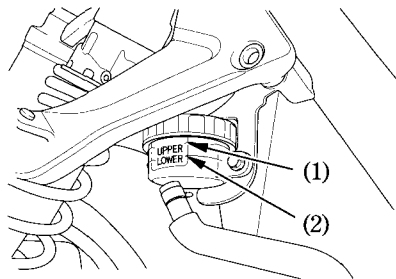

- (1) UPPER level mark
- (2) LOWER level mark

CLUTCH

This motorcycle has a hydraulically actuated clutch. There are no adjustments to perform, but the clutch system must be inspected periodically for fluid level and leakage.

If the motorcycle creeps or stalls when shifted into gear, or if the clutch slips, causing acceleration to lag behind engine speed, there is probably air in the clutch system and it must be bled out. See your Honda dealer for this service.

Fluid Level:

Check that the fluid level is above the LOWER level mark (1) with the motorcycle in an upright position. If the fluid level is near the lower level line, it indicates fluid leakage. See your Honda dealer.

Other Checks:

Make sure there are no fluid leaks. Check for deterioration or cracks in the hoses and fittings.

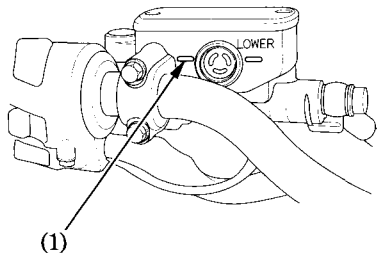

(1) LOWER level mark

Clutch Lever:

The distance between the tip of the clutch lever (1) and the grip can be adjusted by turning the adjuster dial (2).

Turn the adjuster dial while pushing the clutch lever forward.

Align the numbers (3) on the adjuster dial with index mark (4).

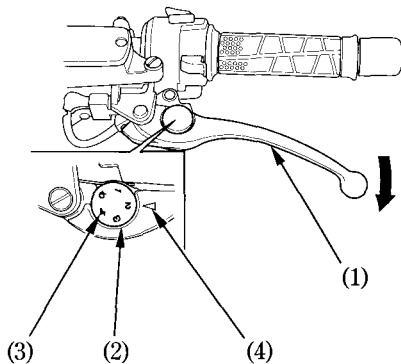

(1) Clutch lever
(2) Adjuster dial

(3) Numbers
(4) Index mark

COOLANT

Coolant Recommendation

< Except SI type >

The owner must properly maintain the coolant to prevent freezing, overheating, and corrosion. Use only high quality ethylene glycol antifreeze containing corrosion protection inhibitors specifically recommended for use in aluminum engines. (SEE ANTIFREEZE CONTAINER LABEL).

Use only low-mineral drinking water or distilled water as a part of the antifreeze solution. Water that is high in mineral content or salt may be harmful to the aluminum engine.

Using coolant with silicate inhibitors may cause premature wear of water pump seals or blockage of radiator passages.

Using tap water may cause engine damage.

The factory provides a 50/50 solution of antifreeze and distilled water in this motorcycle. This coolant solution is recommended for most operating temperatures and provides good corrosion protection. A higher concentration of antifreeze decreases the cooling system performance and is recommended only when additional protection against freezing is needed. A concentration of less than 40/60 (40% antifreeze) will not provide proper corrosion protection. During freezing temperatures, check the cooling system frequently and add higher concentrations of antifreeze (up to a maximum of 60% antifreeze) if required.

<SI type only>

Use only genuine HONDA PRE-MIX COOLANT containing corrosion inhibitors, specifically recommended for aluminum engines when adding or replacing the coolant.

Genuine HONDA PRE-MIX COOLANT is excellent at preventing corrosion and overheating. The effects last for up to 2 years.

The coolant should be inspected and replaced properly by following the maintenance schedule (page 114).

Use any genuine HONDA PRE-MIX COOLANT without diluting with water.

NOTICE

Do not use non-ethylene glycol coolant, tap water, nor mineral water when adding or replacing the coolant.

Use of improper coolant may cause damage, such as corrosions in the engine, blockage of the cooling passage or radiator and premature wear of the water pump seal.

Inspection

The reserve tank is behind the frame.

Check the coolant level in the reserve tank (1) while the engine is at the normal operating temperature with the motorcycle in an upright position. If the coolant level is below the LOWER level mark (2), remove the reserve tank cap (3) and add coolant mixture until it reaches the UPPER level mark (4). Always add coolant to the reserve tank.

Do not attempt to add coolant by removing the radiator cap.

If the reserve tank is empty, or if coolant loss is excessive, check for leaks and see your Honda dealer for repair.

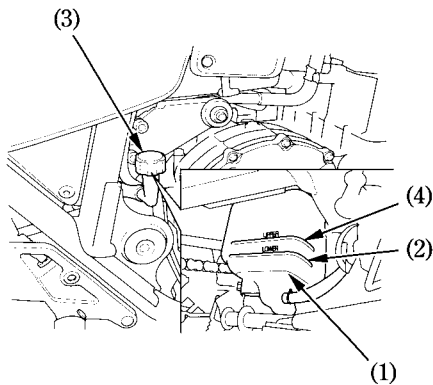

- (1) Reserve tank
- (2) LOWER level mark
- (3) Reserve tank cap
- (4) UPPER level mark

FUEL

Fuel Tank

The fuel tank capacity including the reserve supply is:

21.0 l (5.55 US gal , 4.62 Imp gal)

To open the fuel fill cap (1), insert the ignition key (2) and turn it clockwise. The fuel fill cap is hinged and will lift up.

Do not overfill the tank. There should be no fuel in the filler neck (3).

After refueling, to close the fuel fill cap, push the fuel fill cap into the filler neck until it snaps closed and locks. Remove the key.

⚠ WARNING

Petrol is highly flammable and explosive. You can be burned or seriously injured when handling fuel.

- Stop the engine and keep heat, sparks, and flame away.
- Refuel only outdoors.
- Wipe up spills immediately.

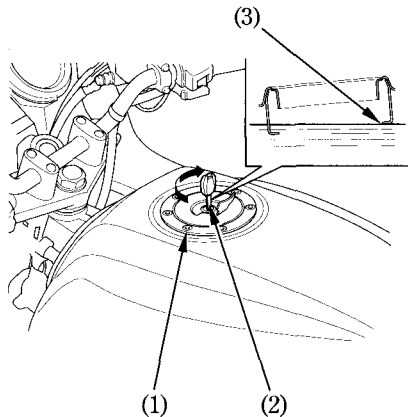

(1) Fuel fill cap
(2) Ignition key

(3) Filler neck

Use unleaded petrol with a research octane number of 91 or higher.

The use of leaded petrol will cause premature damage to the catalytic converters.

NOTICE

If “spark knock” or “pinking” occurs at a steady engine speed under normal load, change brands of petrol. If spark knock or pinking persists, consult your Honda dealer. Failure to do so is considered misuse, and damage caused by misuse is not covered by Honda’s Limited Warranty.

Petrol Containing Alcohol

If you decide to use a petrol containing alcohol (gasohol), be sure it's octane rating is at least as high as that recommended by Honda. There are two types of "gasohol": one containing ethanol, and the other containing methanol. Do not use petrol that contains more than 10 % ethanol. Do not use petrol containing methanol (methyl or wood alcohol) that does not also contain cosolvents and corrosion inhibitors for methanol. Never use petrol containing more than 5 % methanol, even if it has cosolvents and corrosion inhibitors.

< Except BR,SI types >

The use of petrol containing more than 10 % ethanol (or more than 5 % methanol) may:

- Damage the painting of the fuel tank.
- Damage the rubber tubes of the fuel line.
- Cause corrosion of the fuel tank.
- Cause poor drivability.

< BR,SI types >

Fuel system damage or engine performance problems resulting from the use of fuels that contain alcohol is not covered under the warranty. Honda cannot endorse the use of fuels containing methanol since evidence of their suitability is as yet incomplete.

Before buying fuel from an unfamiliar station, try to find out if the fuel contains alcohol. If it does, confirm the type and percentage of alcohol used. If you notice any undesirable operating symptoms while using a petrol that contains alcohol, or one that you think contains alcohol, switch to a petrol that you know does not contain alcohol.

ENGINE OIL

Engine Oil Level Check

Check the engine oil level each day before riding the motorcycle.

The level must be maintained between the upper (1) and lower (2) level marks in the inspection window (3).

1. Start the engine and let it idle for 3–5 minutes. Make sure the low oil pressure indicator goes off. If the indicator light remains on, stop the engine immediately.
2. Stop the engine and hold the motorcycle in an upright position on firm, level ground.

(BR type only)

Stop the engine and put the motorcycle on its center stand on level ground.

3. After 2–3 minutes, check that the oil level is between the upper and lower level marks in the inspection window.
 - If required, clean the inspection window by turning the wiper (4).

4. If required, remove the oil filler cap (5) and add the specified oil (page119) up to the upper level mark. Do not overfill.
5. Reinstall the oil filler cap. Check for oil leaks.

NOTICE

Running the engine with insufficient oil pressure may cause serious engine damage.

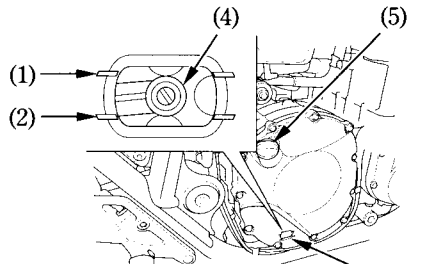

- | | |
|-----------------------|--------------------|
| (1) Upper level mark | (4) Wiper |
| (2) Lower level mark | (5) Oil filler cap |
| (3) Inspection window | |

TUBELESS TYRES

To safely operate your motorcycle, your tyres must be the proper type and size, in good condition with adequate tread, and correctly inflated for the load you are carrying. The following pages give more detailed information on how and when to check your air pressure, how to inspect your tyres for damage, and what to do when your tyres need to be repaired or replaced.

WARNING

Using tyres that are excessively worn or improperly inflated can cause a crash in which you can be seriously hurt or killed.

Follow all instructions in this owner's manual regarding tyre inflation and maintenance.

Air Pressure

Keeping your tyres properly inflated provides the best combination of handling, tread life and riding comfort. Generally, underinflated tyres wear unevenly, adversely affect handling, and are more likely to fail from being overheated.

Overinflated tyres make your motorcycle ride harshly, are more prone to damage from road hazards, and wear unevenly.

We recommend that you visually check your tyres before every ride and use a gauge to measure air pressure at least once a month or any time you think the tyres might be low.

Tubeless tyres have some self-sealing ability if they are punctured. However, because leakage is often very slow, you should look closely for punctures whenever a tyre is not fully inflated.

Always check air pressure when your tyres are “cold” – when the motorcycle has been parked for at least three hours. If you check air pressure when your tyres are “warm” – when the motorcycle has been ridden for even a few miles – the readings will be higher than if the tyres were “cold”. This is normal, so do not let air out of the tyres to match the recommended cold air pressures given below. If you do, the tyres will be underinflated.

The recommended “cold” tyre pressures are:

kPa (kgf/cm ² , psi)		
Driver only	Front	250 (2.50 , 36)
	Rear	290 (2.90 , 42)
Driver and one passenger	Front	250 (2.50 , 36)
	Rear	290 (2.90 , 42)

Inspection

Whenever you check the tyre pressures, you should also examine the tyre treads and sidewalls for wear, damage, and foreign objects:

Look for:

- Bumps or bulges in the side of the tyre or the tread. Replace the tyre if you find any bumps or bulges.
- Cuts, splits or cracks in the tyre. Replace the tyre if you can see fabric or cord.
- Excessive tread wear.

Also, if you hit a pothole or hard object, pull to the side of the road as soon as you can safely and carefully inspect the tyres for damage.

Tread Wear

Replace tyres before tread depth at the center of the tyre reaches the following limit:

Minimum tread depth	
Front:	1.5 mm (0.06 in)
Rear:	2.0 mm (0.08 in)

<For Germany>

German law prohibits use of tyres whose tread depth is less than 1.6 mm.

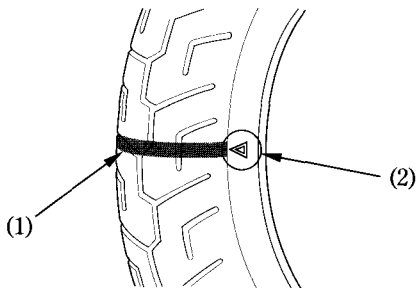

- (1) Wear indicator
- (2) Wear indicator location mark

Tyre Repair

If a tyre is punctured or damaged, you should replace it, not repair it. As discussed below, a tyre that is repaired, either temporarily or permanently, will have lower speed and performance limits than a new tyre.

A temporary repair, such as an external tubeless tyre plug, may not be safe for normal speeds and riding conditions. If a temporary or emergency repair is made to a tyre, you should ride slowly and cautiously to a dealer and have the tyre replaced. If possible, you should not carry a passenger or cargo until a new tyre is installed.

Even if a tyre is professionally repaired with a permanent internal patch plug, it will not be as good as a new tyre. You should not exceed 80 km/h (50 mph) for the first 24 hours, or 130 km/h (80 mph) at any time thereafter. In addition, you may not be able to safely carry as much weight as with a new tyre. Therefore, we strongly recommend that you replace a damaged tyre. If you choose to have a tyre repaired, be sure the wheel is balanced before you ride.

Tyre Replacement

The tyres that came on your motorcycle were designed to match the performance capabilities of your motorcycle and provide the best combination of handling, braking, durability and comfort.

WARNING

Installing improper tyres on your motorcycle can affect handling and stability. This can cause a crash in which you can be seriously hurt or killed.

Always use the size and type of tyres recommended in this owner's manual.

The recommended tyres for your motorcycle are:

Front: 120/70ZR17M/C (58W)
DUNLOP
D220FST K

Rear: 180/55ZR17M/C (73W)
DUNLOP
D220ST K

Type: radial, tubeless

Whenever you replace a tyre, use one that is equivalent to the original and be sure the wheel is balanced after the new tyre is installed.

Important Safety Reminders

- Do not install a tube inside a tubeless tyre on this motorcycle. Excessive heat build-up can cause the tube to burst.
- Use only tubeless tyres on this motorcycle. The rims are designed for tubeless tyres, and during hard acceleration or braking, a tube-type tyre could slip on the rim and cause the tyre to rapidly deflate.

ESSENTIAL INDIVIDUAL COMPONENTS

IGNITION SWITCH

The ignition switch (1) is below the indicator panel.

The headlight, position light (except U type), taillight and license light will come on whenever you turn the ignition switch ON. If your motorcycle is stopped with the ignition switch ON and the engine is not running, the headlight, position light (except U type), taillight and license light will still be on, resulting in battery discharge.

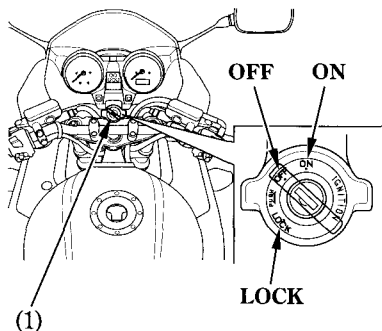

(1) Ignition switch

Key Position	Function	Key Removal
LOCK (steering lock)	Steering is locked. Engine and lights cannot be operated.	Key can be removed
OFF	Engine and lights cannot be operated.	Key can be removed
ON	Engine and lights can be operated.	Key cannot be removed

KEYS

This motorcycle has two keys (1) and a key number plate (2).

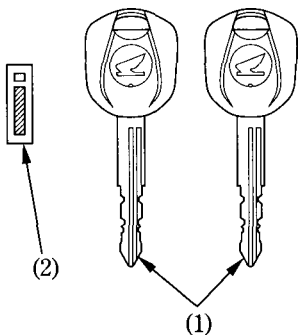

(1) Keys

(2) Key number plate

You will need the key number if you ever have to replace a key. Store the plate in a safe place.

To reproduce keys, bring all keys, key number plate and motorcycle to your Honda dealer.

Up to four keys can be registered with the immobilizer system (HISS), including the ones in hand.

If all keys are lost, the PGM-FI unit/ignition control module must be replaced. To avoid this possibility we recommend that if only one key is left, you immediately have it reproduced to ensure that a back-up is available.

These keys contain electronic circuits that are activated by the immobilizer system (HISS). They will not work to start the engine if the circuits are damaged.

- Do not drop the keys or set heavy objects on them.
- Do not grind, drill or in any way alter the original shape of the keys.
- Keep the keys away from magnetic objects.

IMMOBILIZER SYSTEM (HISS)

HISS is the abbreviation of Honda Ignition Security System.

The immobilizer system (HISS) protects your motorcycle from theft. A properly-coded key must be used in the ignition switch for the engine to start. If an improperly-coded key (or other device) is used the engine's starting circuit is disabled.

When the ignition switch is turned ON and the engine stop switch is at "O" (RUN), the immobilizer system (HISS) indicator lights for a few seconds, then goes off. If the indicator remains on, it means the system does not recognize the coding of the key. Turn the ignition switch to OFF, remove the key, reinsert and turn the switch ON again.

The immobilizer system has such a function that keeps the immobilizer system (HISS) indicator (1) blinking at 2 second intervals for 24 hours. This blinking function can be turned on or off.

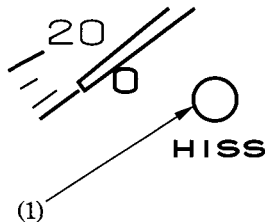

(1) Immobilizer system (HISS) indicator

To alter the blinking function:

1. Turn the ignition switch ON.
2. Press and hold the left control button (2) for more than 2 seconds when the display function mode is odometer.
3. The immobilizer system (HISS) indicator will begin flashing.
4. Turn the ignition switch OFF.

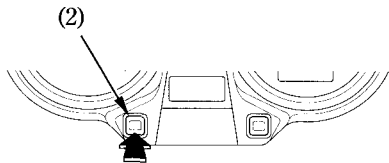

(2) Left control button

If the system repeatedly does not recognize the coding of your key, contact your Honda dealer.

- The system may not recognize the key's coding if any other immobilizer key is near the ignition switch. To make sure the system recognizes the key code, keep each immobilizer key on a separate ring.
- Do not attempt to alter the immobilizer system (HISS) or add other devices to it. Electrical problems could result, making it impossible to start your motorcycle.
- If all keys are lost, the PGM-FI unit/ignition control module must be replaced.

EC Directives

This immobilizer system complies with the R & TTE (Radio equipment and telecommunications terminal equipment and the mutual recognition of their conformity) Directive.



The declaration of conformity to R & TTE Directive is provided to the owner at the time of purchase. The declaration of conformity should be kept at a safe place. When the declaration of conformity is lost or is not provided, contact your Honda dealer.

〈South Africa only〉



〈BR type only〉



Agência Nacional de Telecomunicações

0542-08-3333







(01) 07898921465038

This equipment operates on a secondary basis and, consequently, must accept harmful interference, including from stations of the same kind, and may not cause harmful interference to systems operating on a primary basis.

RIGHT HANDLEBAR CONTROLS

Engine Stop Switch

The engine stop switch (1) is next to the throttle grip. When the switch is in the  (RUN) position, the engine will operate. When the switch is in the  (OFF) position, the engine will not operate. This switch is intended primarily as a safety or emergency switch and should normally remain in the  (RUN) position.

If your motorcycle is stopped with the ignition switch ON and the engine stop switch  (OFF), the headlight, position light (except U type), taillight and license light will still be on, resulting in battery discharge.

Start Button

The start button (2) is below the engine stop switch (1).

The start button is used for starting the engine. Pushing the button in starts the engine. See Starting Procedure, page 100.

When the start button is pushed, the starter motor will crank the engine and the headlight will automatically go out, but the position light (except U type), taillight and license light will stay on.

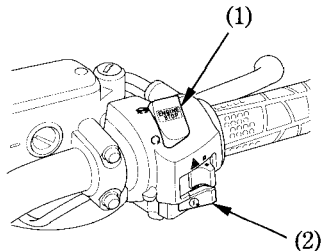

- (1) Engine stop switch
- (2) Start button

Hazard Switch

The hazard switch (1) should be used only when your motorcycle is stopped under emergency or hazardous conditions. To activate the hazard lights, turn the ignition key to the ON position, and then slide the hazard switch marked . The front and rear turn signals will blink simultaneously.

Be sure to turn the switch off when the hazard warning is no longer required, or the turn signals will not work properly, and may confuse other drivers.

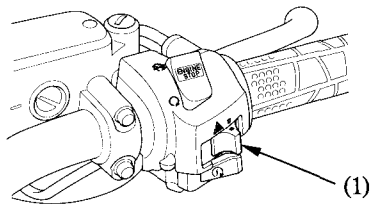

If all the turn signals are left blinking with the engine stopped, the battery will be discharged.



(1) Hazard switch

LEFT HANDLEBAR CONTROLS



Headlight Dimmer Switch (1)

Push the headlight dimmer switch to  (HI) to select high beam or to  (LO) to select low beam.

Passing Light Control Switch (2)

When this switch is pressed, the headlight flashes on to signal approaching cars or when passing.

Turn Signal Switch (3)

Move to  (L) to signal a left turn,  (R) to signal a right turn. Press to turn signal off.

Horn Button (4)

Press the button to sound the horn.

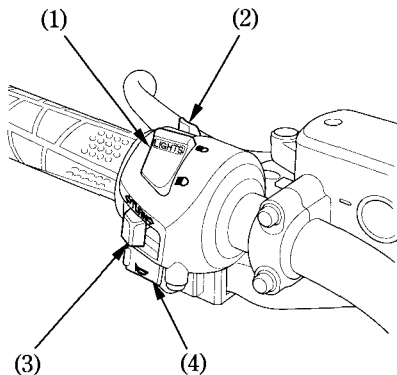

- (1) Headlight dimmer switch
- (2) Passing light control switch
- (3) Turn signal switch
- (4) Horn button

FEATURES

(Not required for operation)

STEERING LOCK

To lock the steering, turn the handlebar all the way to the left, turn the ignition key (1) to LOCK while pushing in. Remove the key. To unlock the steering, turn the key to OFF while pushing in.

Do not turn the key to LOCK while riding the motorcycle; loss of vehicle control will result.

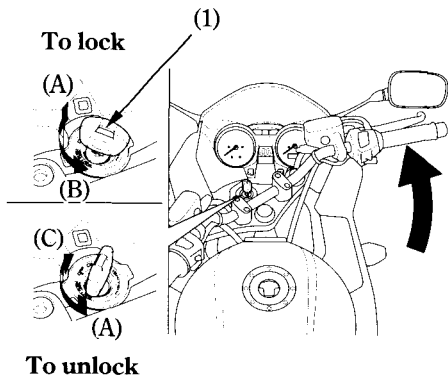

(1) Ignition key

(A) Push in

(B) Turn to LOCK

(C) Turn to OFF

SEAT

To remove the seat (1), insert the ignition key into the seat lock (2) and turn it clockwise. Pull the seat lock lever (3) downward to unlock the seat. Pull the seat back and up.

To install the seat, insert the front prong (4) into the front stay (5) and the rear prongs (6) into the rear stays (7) on the frame. Push forward and then down on the rear of the seat.

Be sure the seat is locked securely in position after installation.

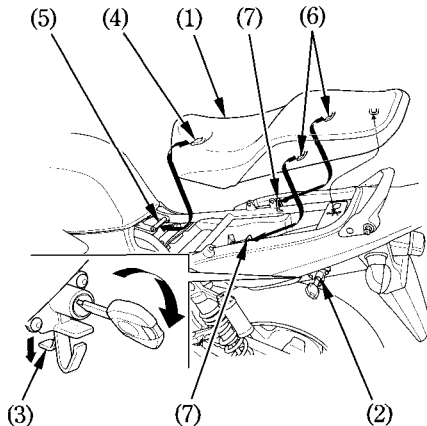

- | | |
|-----------------|-----------------|
| (1) Seat | (5) Front stay |
| (2) Seat lock | (6) Rear prongs |
| (3) Lock lever | (7) Rear stays |
| (4) Front prong | |

HELMET HOLDER

The helmet holder (1) is on the left side below the seat.

Insert the ignition key (2) and turn it clockwise to unlock. Hang your helmet on the holder hook (3). Turn the key counterclockwise to lock the holder hook and then remove the key.

⚠ WARNING

Riding with a helmet attached to the holder can interfere with the rear wheel or suspension and could cause a crash in which you can be seriously hurt or killed.

Use the helmet holder only while parked. Do not ride with a helmet secured by the holder.

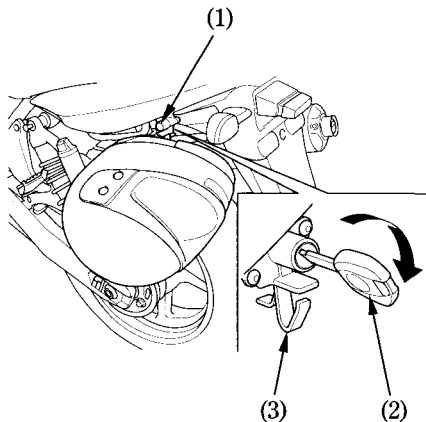

- (1) Helmet holder
- (2) Ignition key
- (3) Holder hook

DOCUMENT BAG

The document bag (1) is in the document compartment (2) under the seat (page 81). This owner's manual and other documents should be stored in the document bag.

When washing your motorcycle, be careful not to flood this area with water.

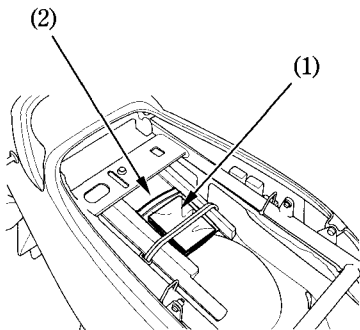

- (1) Document bag
- (2) Document compartment

CENTER COMPARTMENT

The center compartment (1) is below the seat (page 81).

This compartment is for light weight items. Cargo in the storage compartment should not exceed:

3.0 kg (6.6 lbs)

Never exceed the maximum weight limit; handling and stability may be severely affected.

The center compartment may become heated by the engine. Do not store food and other articles which are flammable or susceptible to heat damage in this compartment.

Do not direct water under pressure against the center compartment as water will be forced into the compartment.

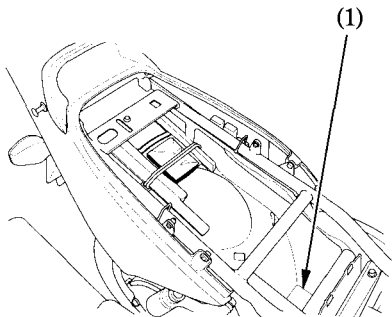

(1) Center compartment

STORAGE COMPARTMENT FOR U-SHAPED ANTI-THEFT LOCK

The rear fender has a storage compartment to store a U-shaped anti-theft lock under the seat (page 81). After storing, be sure to fasten the lock with the rubber band (1) securely.

Some U-shaped locks may not be stored in the compartment due to their size or design.

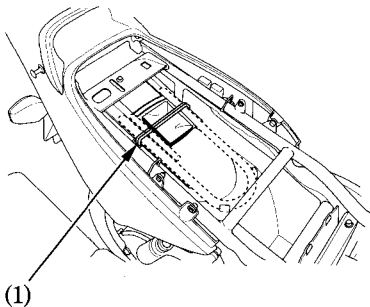

(1) Rubber band

RIGHT POCKET CB1300S/SA

There is right pocket (1) below the right side of the handlebar.

The maximum allowable load in the right pocket shall be no more than:

0.5 kg (1.0 lbs)

Do not open the right pocket while riding the motorcycle.

To open the right pocket pull the right pocket cover (2).

Make sure the right pocket cover is closed before riding.

When washing your motorcycle be careful not to flood this area with water.

Do not store valuables or fragile articles in the right pocket.

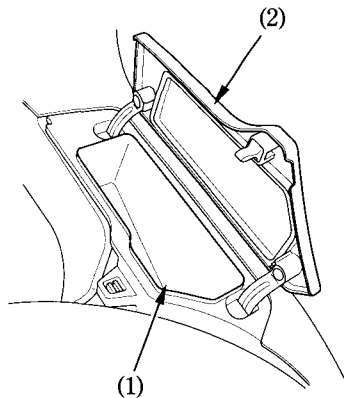

- (1) Right pocket
- (2) Right pocket cover

LEFT POCKET

CB1300S/SA

There is left pocket (1) below the left side of the handlebar.

The maximum allowable load in the left pocket shall be no more than:

0.5 kg (1.0 lbs)

Do not open the left pocket while riding the motorcycle.

To open the left pocket, insert the ignition key (2), turn it clockwise.

Make sure the left pocket cover (3) is closed before riding.

When washing your motorcycle be careful not to flood this area with water.

Do not store valuables or fragile articles in the left pocket.

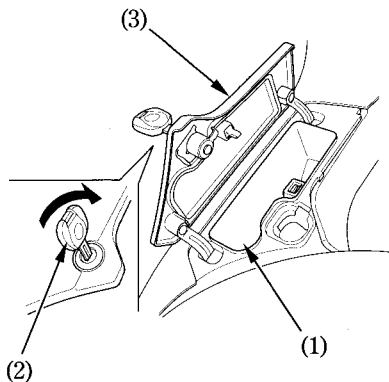

- (1) Left pocket
- (2) Ignition key
- (3) Left pocket cover

SIDE COVERS

The right side cover must be removed for the air cleaner maintenance. The left side cover must be removed for fuse maintenance.

The right and left side covers can be removed in the same manner.

Removal:

1. Remove the seat (page 81).
2. Remove the bolt (1).
3. Remove the prongs (2) from the grommets (3).

Installation:

1. Position the cover so the prongs are aligned with the frame grommets.
2. Push the prongs in.
3. Install the bolt.
4. Install the seat.

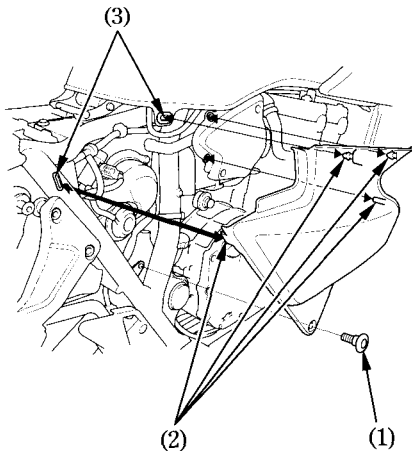

- (1) Bolt
(2) Prongs
(3) Grommets

LOWER COWL CB1300S/SA

The lower cowl must be removed to remove the left side cowl or replace the position light bulb (except U type).

Removal:

1. Remove the clips (1) (page 94).
2. Remove the bolts (2).
3. Remove the lower cowl (3).

Installation:

- Installation can be done in the reverse order of removal.

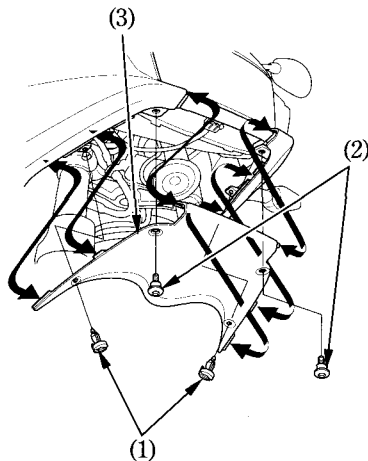

- (1) Clips
- (2) Bolts
- (3) Lower cowl

LEFT SIDE COWL

CB1300S/SA

The left side cowl must be removed to replace the headlight bulb.

Removal:

1. Remove the lower cowl (page 89).
2. Remove the clips (1) (page 94).
3. Remove the screw A (2).
4. Remove the meter cover (3).
5. Use the 6 mm hex wrench (4) and extension bar (5) to remove the bolts (6).
6. Remove the screw B (7).
7. Remove the left side cowl (8) and disconnect the front turn signal connector (9).

Installation:

- Installation can be done in the reverse order of removal.

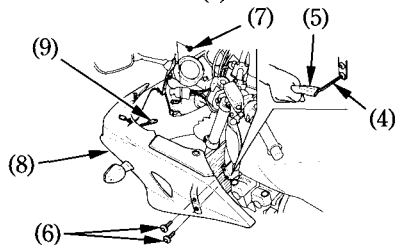
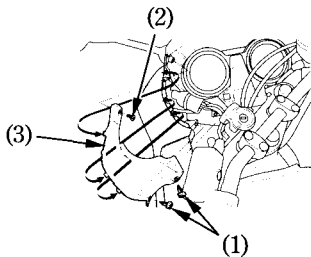

- | | |
|--------------------|---------------------------------|
| (1) Clips | (6) Bolts |
| (2) Screw A | (7) Screw B |
| (3) Meter cover | (8) Left side cowl |
| (4) 6mm hex wrench | (9) Front turn signal connector |
| (5) Extension bar | |

FUEL TANK MAINTENANCE POSITION

The front of the fuel tank can be tilted up for the spark plug maintenance.

The fuel tank does not require draining.

To Raise:

1. Place the motorcycle on its side stand with the transmission in neutral and the ignition switch off.

(BR type only)

Place the motorcycle on its center stand with the transmission in neutral and the ignition switch off.

2. Make the handlebar straight.
3. Remove the right and left side covers (page 88).
4. Remove the bolts (1).
5. Pull up the rear end of the fuel tank and release the tank from the cushion rubbers (2) on the frame.

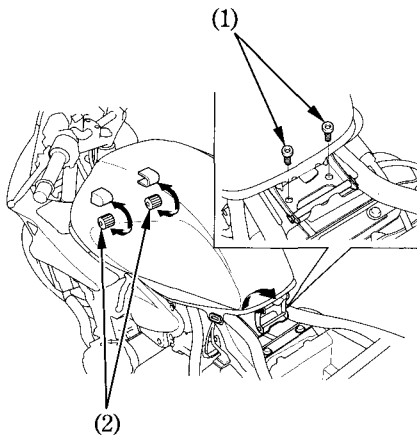

- (1) Bolts
(2) Cushion rubbers

6. Topple the rear bracket (3).
7. Make a suitable prop by inserting a Standard/Phillips screwdriver (4) from the tool kit in the screwdriver handle (5).
8. Raise the front of the fuel tank (6) and place the Standard/Phillips screwdriver and screwdriver handle between the front of the fuel tank and frame body.

Do not raise the fuel tank higher than the wire allows.

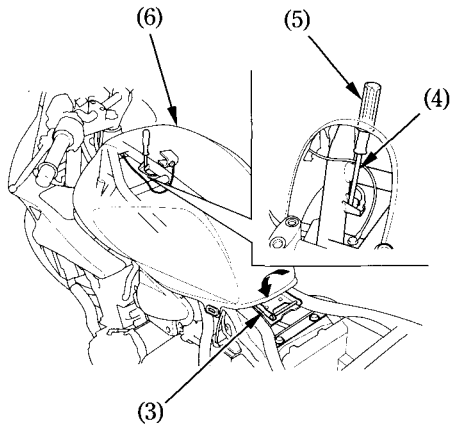

- (3) Rear bracket
- (4) Standard/Phillips screwdriver
- (5) Screwdriver handle
- (6) Fuel tank

HEADLIGHT AIM VERTICAL ADJUSTMENT

CB1300S/SA

Vertical adjustment can be made by turning the knob (1) in or out as necessary.

Obey local laws and regulations.

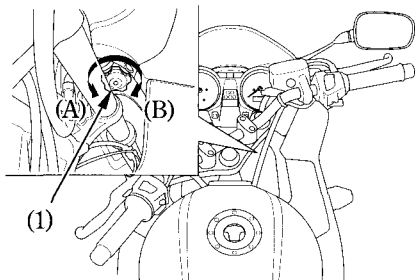

(1) Knob

(A) Up

(B) Down

CB1300/A

Vertical adjustment can be made by moving the headlight case (1) as necessary.

To move the headlight case, loosen the bolts (2).

Tighten the bolts after adjustment.

Obey local laws and regulations.

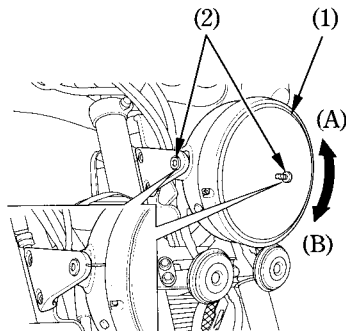

(1) Headlight case

(2) Bolts

(A) Up

(B) Down

CLIP

Removal:

- ① Press down on the center pin to release the lock.
- ② Pull out the clip A from the hole.

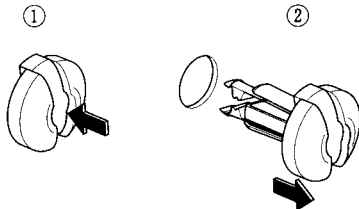

Installation:

- ① Slightly open the retaining pawls and then push them out.
- ② Insert the clip A into the hole.
- ③ Lightly press down on the center pin to lock the clip A.

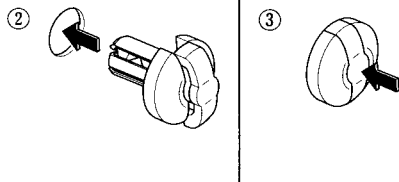
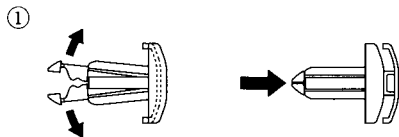

Removal:

- ① Remove the pin by a Phillips screwdriver.
- ② Pull out the clip B from the hole.

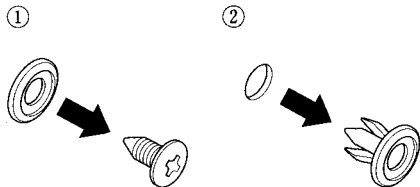

Installation:

- ① Insert the clip B into the hole.
- ② Push the pin in.

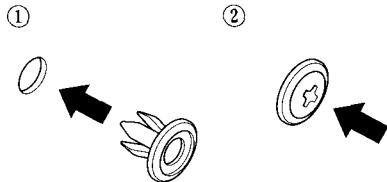

OPERATION

PRE-RIDE INSPECTION

For your safety, it is very important to take a few moments before each ride to walk around your motorcycle and check its condition. If you detect any problem, be sure you take care of it, or have it corrected by your Honda dealer.

WARNING

Improperly maintaining this motorcycle or failing to correct a problem before riding can cause a crash in which you can be seriously hurt or killed.

Always perform a pre-ride inspection before every ride and correct any problems.

1. Engine oil level—add engine oil if required (page 64). Check for leaks.
2. Fuel level—fill fuel tank when necessary (page 61). Check for leaks.
3. Coolant level—add coolant if required. Check for leaks (pages 58 — 60).
4. Front and rear brakes—check operation; make sure there is no brake fluid leakage (pages 53 — 55).

5. Tyres—check condition and pressure (pages 65 – 70).
6. Drive chain—check condition and slack (page 134). Adjust and lubricate if necessary.
7. Throttle—check for smooth opening and full closing in all steering positions.
8. Lights and horn—check that headlight, brake/tail light, position light (except U type), license light, turn signals, indicators and horn function properly.
9. Engine stop switch—check for proper function (page 77).
10. Side stand ignition cut-off system—check for proper function (page 143).

STARTING THE ENGINE

Always follow the proper starting procedure described below.

This motorcycle is equipped with a side stand ignition cut-off system. The engine cannot be started if the side stand is down, unless the transmission is in neutral. If the side stand is up, the engine can be started in neutral or in gear with the clutch lever pulled in. After starting with the side stand down, the engine will shut off if the transmission is put in gear before raising the side stand.

To protect the catalytic converters in your motorcycle's exhaust system, avoid extending idling and the use of leaded petrol.

Your motorcycle's exhaust contains poisonous carbon monoxide gas. High levels of carbon monoxide can collect rapidly in enclosed areas such as a garage. Do not run the engine with the garage door closed. Even with the door open, run the engine only long enough to move your motorcycle out of the garage.

Do not use the electric starter for more than 5 seconds at a time. Release the start button for approximately 10 seconds before pressing it again.

Preparation

Before starting, insert the key, turn the ignition switch ON and confirm the following:

- The transmission is in neutral (neutral indicator is ON).
- The engine stop switch is at \odot (RUN).
- The low oil pressure indicator is ON.
- The PGM-FI malfunction indicator lamp (MIL) is OFF.
- The high coolant temperature indicator is OFF.
- The immobilizer system (HISS) indicator is OFF.
- The ABS indicator is ON.
(CB1300A/SA)

The low oil pressure indicator should go off a few seconds after the engine starts. If the low oil pressure indicator lights during operation, stop the engine immediately and check the engine oil level.

(CB1300A/SA)

The ABS indicator should go off after you ride the motorcycle at a speed above 10 km/h (6 mph).

NOTICE

Operating the engine with insufficient oil pressure can cause serious engine damage.

Starting Procedure

This motorcycle has a fuel-injected engine with an automatic choke. Follow the procedure indicated below.

Any Air Temperature:

1. With the throttle completely closed, press the start button.

The engine will not start if the throttle is fully open (because the electronic control module cuts off the fuel supply).

Snapping the throttle or fast idling for more than about 5 minutes at normal air temperature may cause exhaust pipe discoloration.

Flooded Engine

If the engine fails to start after repeated attempts, it may be flooded.

1. Leave the engine stop switch set to  (RUN).
2. Open throttle fully.
3. Press the start button for 5 seconds.
4. Follow the normal starting procedure.

If the engine starts with unstable idle, open the throttle slightly.

If the engine does not start, wait for 10 seconds, then follow steps 1–4 again.

Ignition Cut Off

Your motorcycle is designed to automatically stop the engine and fuel pump if the motorcycle is over-turned (a banking sensor cuts off the ignition system). Before restarting the engine, you must turn the ignition switch to the OFF position and then back to ON.

RUNNING-IN

Help assure your motorcycle's future reliability and performance by paying extra attention to how you ride during the first 500 km (300 miles).

During this period, avoid full-throttle starts and rapid acceleration.

RIDING

Review Motorcycle Safety (pages 1 – 7) before you ride.

Make sure you understand the function of the side stand mechanism. (See MAINTENANCE SCHEDULE on page 115 and explanation for SIDE STAND on page 143).

Make sure flammable materials such as dry grass or leaves do not come in contact with the exhaust system when riding, idling, or parking your motorcycle.

1. After the engine has been warmed up, the motorcycle is ready for riding.
2. While the engine is idling, pull in the clutch lever and depress the shift lever to shift into 1st (low) gear.
3. Slowly release the clutch lever and at the same time gradually increase engine speed by opening the throttle. Coordination of the throttle and clutch lever will assure a smooth positive start.

4. When the motorcycle attains a moderate speed, close the throttle, pull in the clutch lever and shift to 2nd gear by raising the shift lever.

This sequence is repeated to progressively shift to 3rd, 4th and 5th (top) gears.

5. Coordinate the throttle and brakes for smooth deceleration.
6. Both front and rear brakes should be used at the same time and should not be applied strongly enough to lock the wheel, or braking effectiveness will be reduced and control of the motorcycle be difficult.

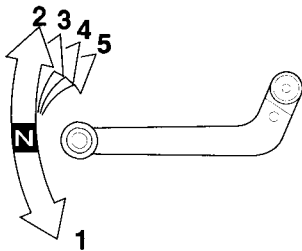

BRAKING

For normal braking, apply both the brake pedal and lever while down-shifting to match your road speed. For maximum braking, close the throttle and firmly apply the pedal and lever; pull in the clutch lever before coming to a complete stop to prevent stalling the engine.

Important Safety Reminders:

- Independent operation of only the brake lever or brake pedal reduces stopping performance.
- Extreme application of the brake controls may cause wheel lock, reducing control of the motorcycle.
- When possible, reduce speed or brake before entering a turn; closing the throttle or braking in mid-turn may cause wheel slip. Wheel slip will reduce control of the motorcycle.

- When riding in wet or rainy conditions, or on loose surfaces, the ability to maneuver and stop will be reduced. All of your actions should be smooth under these conditions. Rapid acceleration, braking or turning may cause loss of control. For your safety, exercise extreme caution when braking, accelerating or turning.
- When descending a long, steep grade, use engine compression braking by down-shifting, with intermittent use of both brakes.
Continuous brake application can overheat the brakes and reduce their effectiveness.
- Riding with your foot resting on the brake pedal or your hand on the brake lever may actuate the brakelight, giving a false indication to other drivers. It may also overheat the brakes, reducing effectiveness.

Anti-lock Brake System (ABS) CB1300A/SA

This model is also equipped with an Anti-lock Brake System (ABS) designed to help prevent wheel lock up during hard braking on uneven or other poor surfaces while running straight. Although the wheel may not lock up—if you are braking too hard in a turn the motorcycle can still lose traction, causing a loss of control.

In some situations, a motorcycle with ABS may require a longer stopping distance to stop on loose or uneven surfaces than an equivalent motorcycle without ABS.

ABS cannot make up for road conditions, bad judgment, or improper operation of the brakes. It is still your responsibility to ride at reasonable speeds for weather, road surface, and traffic conditions, and to leave a margin of safety.

ABS is self-checking and always on.

- ABS may be activated by riding over a sharp drop or rise in the road level. It is important to follow the tyre recommendations (page 65). The ABS computer works by comparing wheel speed. Non-recommended tyres can affect wheel speed and may confuse the ABS computer.
- ABS does not function at low speeds (approximately 10 km/h (6 mph) or below).
- ABS does not function if the battery is discharged.

ABS Indicator CB1300A/SA

Normally, this indicator comes on when the ignition is turned ON, and goes off after you ride the motorcycle at speed above 10 km/h (6 mph). If there is an ABS problem, the indicator flashes and remains on. The ABS system does not operate when the ABS indicator is on.

If the ABS indicator comes on while riding, stop the motorcycle in a safe place and turn off the engine.

Turn the ignition ON again. The indicator should come on, and go off after you ride the motorcycle at speeds above 10 km/h (6 mph). If it does not go off, ABS is not functioning, but the brakes still work provide normal stopping ability. However, you should have the system checked by Honda dealer as soon as possible.

The ABS indicator may flash if you turn the rear wheel while the motorcycle is upright on the stand. This is normal. Turn the ignition OFF, then turn it ON. The indicator should come on, then go off after you run the motorcycle above 30 km/h (19 mph).