

NIGHTHAWK S

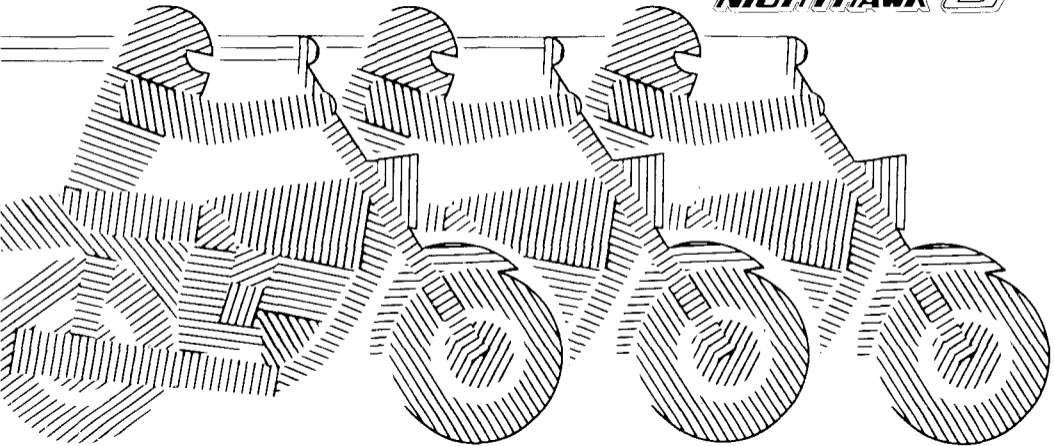

IMPORTANT NOTICE

- **OPERATOR AND PASSENGER**

This motorcycle is designed to carry the operator and one passenger. Never exceed the vehicle capacity load as shown on the tire information label.

- **ON-ROAD USE**

This motorcycle is not equipped with a spark arrester and is designed to be used only on the road. Operation in forest, brush, or grass covered areas may be illegal. Obey local laws and regulations.

- **READ THIS OWNER'S MANUAL CAREFULLY**

Pay special attention to statements preceded by the following words:

 **WARNING**

Indicates a strong possibility of severe personal injury or loss of life if instructions are not followed.

CAUTION:

Indicates a possibility of personal injury or equipment damage if instructions are not followed.

NOTE: Gives helpful information.

This manual should be considered a permanent part of the motorcycle and should remain with the motorcycle when resold.

**HONDA CB750SC
OWNER'S MANUAL**

1984

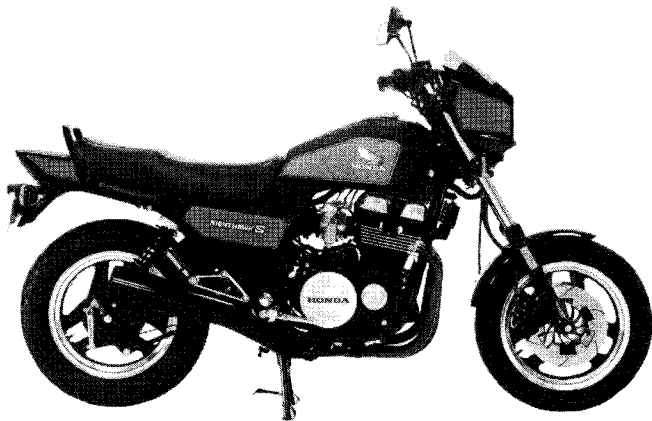

All information in this publication is based on the latest product information available at the time of approval for printing. HONDA MOTOR CO., LTD. reserves the right to make changes at any time without notice and without incurring any obligation. No part of this publication may be reproduced without written permission.

© Honda Motor Co., Ltd. 1983

WELCOME

The motorcycle presents you a challenge to master the machine, a challenge to adventure. You ride through the wind, linked to the road by a vehicle that responds to your commands as no other does. Unlike an automobile, there is no metal cage around you. Like an airplane, a pre-ride inspection and regular maintenance are essential to your safety. Your reward is freedom.

To meet the challenges safely, and to enjoy the adventure fully, you should become thoroughly familiar with this owner's manual **BEFORE YOU RIDE THE MOTOR-CYCLE.**

When service is required, remember that your Honda dealer knows your motorcycle best. If you have the required mechanical "know-how" and tools, your dealer can supply you with an official Honda Shop Manual to help you perform many maintenance and repair tasks.

Pleasant riding, and thank you for choosing a Honda!

OPERATION

Page

Page

1	MOTORCYCLE SAFETY	29	ESSENTIAL INDIVIDUAL COMPONENTS
3	Safe Riding Rules	29	Ignition Switch
4	Protective Apparel	30	Engine Stop Switch
4	Modifications	30	Starter Button
5	Loading and Accessories	31	Left Handlebar Controls
7	PARTS LOCATION		
10	Instruments and Indicators	32	FEATURES (Not required for operation)
14	MAJOR COMPONENTS (Information you need to operate this motorcycle)	32	Steering Lock
14	T.R.A.C. Anti-dive Adjuster	32	Helmet Holder
15	Suspension	33	Document Compartment
18	Brakes	34	OPERATION
21	Clutch	34	Pre-ride Inspection
22	Fuel	35	Starting the Engine
24	Engine Oil	38	Break-in
26	Final drive oil	39	Riding
27	Tubeless Tires	41	Braking
		42	Parking
		42	Anti-theft Tips

MAINTENANCE

Page		Page	
43	MAINTENANCE	58	FRAME/WHEELS/BRAKES
44	Maintenance Schedule	58	Handlebars
46	Maintenance Record	59	Front Wheel Removal
47	Tool Kit	62	Rear Wheel Removal
48	Serial Numbers	64	Brake Shoe/Pad Wear
49	Color Label	65	Side Stand
50	Maintenance Precautions		
		66	ELECTRICAL
51	FILTERS/LUBRICATION	66	Battery
51	Air Cleaner	68	Fuse Replacement
52	Crankcase Breather		
53	Engine Oil and Filter	70	CLEANING
55	ENGINE	71	STORAGE GUIDE
55	Spark Plugs		
56	Idle Speed	73	SPECIFICATIONS
57	DRIVE TRAIN	77	CONSUMER INFORMATION
57	Final Drive Oil	77	Vehicle Stopping Distance
		78	Emission Control System

MOTORCYCLE SAFETY

Read these WARNING LABELS before you ride!

REMEMBER ■ PRESERVE NATURE
■ ALWAYS WEAR A HELMET ■ RIDE SAFELY
■ READ OWNER'S MANUAL CAREFULLY BEFORE RIDING

WARNING : ACCESSORIES AND LOADING

- THE SAFETY, STABILITY AND HANDLING OF THIS MOTORCYCLE MAY BE ADVERSELY AFFECTED BY THE ADDITION OF ACCESSORIES AND CARGO.
- READ AND UNDERSTAND THE WARNING CONTAINED IN THE OWNER'S MANUAL AND THE INSTRUCTIONS IN THE ACCESSORY HANDBOOK BEFORE INSTALLING ANY ACCESSORY.
- THE WEIGHT OF ACCESSORIES AND CARGO MUST BE ADDED TO THE WEIGHT OF THE RIDER AND PASSENGER WHEN DETERMINING IF THE VEHICLE CAPACITY LOAD HAS BEEN EXCEEDED.
- THE CARGO LOAD MUST NOT EXCEED 18 KG (40 LBS) UNDER ANY CIRCUMSTANCES.
- THE FITTING OF LARGE FORK-MOUNTED OR LARGE HANDLEBAR-MOUNTED FAIRING IS NOT RECOMMENDED.

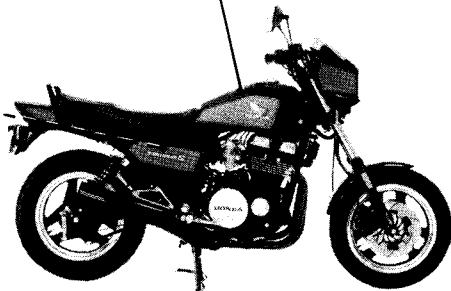

M
O
T
O
R
C
Y
C
L
E

S
A
F
E
T
Y

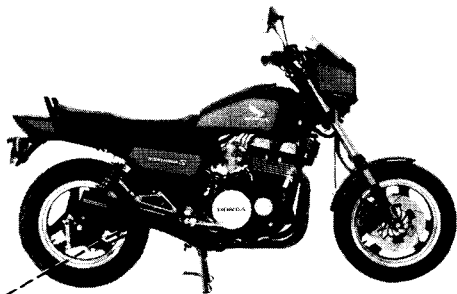

IMPORTANT INFORMATION

COLD TIRE PRESSURES :

[UP TO VEHICLE CAPACITY LOAD] FRONT 225 kPa, 2.25 kg/cm², 32 psi
 REAR 280 kPa, 2.80 kg/cm², 40 psi

[UP TO 90 kg (200 lbs.) LOAD] FRONT 225 kPa, 2.25 kg/cm², 32 psi
 REAR 225 kPa, 2.25 kg/cm², 32 psi

VEHICLE CAPACITY LOAD 170 kg (370 lbs)

TIRE SIZE : FRONT 110/90-16 59H REAR 130/90-16 67H

TIRE BRAND	FRONT	REAR
BRIDGESTONE	G511	G508
DUNLOP	K527A	K627
MIN. RECOMMENDED CENTER TREAD DEPTH		
FRONT 1.5 mm (0.06 in.) REAR 2.0 mm (0.08 in.)		

Read Owner's manual

THIS MOTORCYCLE
 EQUIPPED WITH
 TUBELESS TIRES

SAFE RIDING RULES

WARNING

* *Motorcycle riding requires special efforts on your part to ensure your safety. Know these requirements before you ride.*

1. Always make a pre-ride inspection (page 34) before you start the engine.
You may prevent an accident or equipment damage.
2. Many accidents involve inexperienced riders. Most states require a special motorcycle riding test or license. Make sure you are qualified before you ride. NEVER lend your motorcycle to an inexperienced rider.
3. Many automobile/motorcycle accidents happen because the automobile driver does not “see” the motorcyclist. Make yourself conspicuous to help avoid the accident that wasn’t your fault:
 - Wear bright or reflective clothing.
 - Don’t ride in another motorist’s “blind spot.”
4. Obey all federal, state, and local laws and regulations.
 - Excessive speed is a factor in many accidents. Obey the speed limits, and NEVER travel faster than conditions warrant.
 - Signal before you make a turn or lane change. Your size and maneuverability can surprise other motorists.
5. Don’t let other motorists surprise you. Use extra caution at intersections, parking lot entrances and exits, and driveways.
6. Keep both hands on the handlebars and both feet on the footpegs while riding. A passenger should hold on to the motorcycle or the operator with both hands and keep both feet on the passenger footpegs.

PROTECTIVE APPAREL

1. Most motorcycle accident fatalities are due to head injuries: **ALWAYS** wear a helmet. You should also wear a face shield or goggles, boots, gloves, and protective clothing. A passenger needs the same protection.
2. The exhaust system becomes very hot during operation, and it remains hot after operation. Never touch any part of the hot exhaust system. The front frame down tubes may also become very warm. Wear clothing that fully covers your legs.
3. Do not wear loose clothing which could catch on the control levers, footpegs, or wheels.

MODIFICATIONS



Modification of the motorcycle, or removal of original equipment may render the vehicle unsafe or illegal. Obey all federal, state, and local equipment regulations.

LOADING AND ACCESSORIES

WARNING

** To prevent an accident, use extreme care when adding and riding with accessories and cargo. Addition of accessories and cargo can reduce a motorcycle's stability, performance and safe operating speed. Never ride an accessory equipped motorcycle at speeds above 80 mph. And remember that this 80 mph limit may be reduced by installation of non-Honda accessories, improper loading, worn tires and overall motorcycle condition, poor road or weather conditions, etc. These general guidelines may help you decide whether or how to equip your motorcycle, and how to load it safely.*

Loading

The combined weight of the rider, passenger, cargo and additional accessories must not exceed 370 lbs (170 kg), the vehicle capacity load. Cargo weight alone should not exceed 40 lbs.

1. Keep cargo and accessory weight low and close to the center of the motorcycle. Load weight equally on both sides to minimize imbalance. As weight is located farther from the motorcycle's center of gravity, handling is proportionally affected.
2. Adjust the pressure (page 2), front suspension (page 15) and rear suspension (pages 16, 17) to suit load weight and riding conditions.
3. Luggage racks are for lightweight items. Do not carry more than 40 lbs. of cargo on a luggage rack behind the seat. Bulky items too far behind the rider may cause wind turbulence that impairs handling.
4. All cargo and accessories must be secure for stable handling. Recheck cargo security and accessory mounts frequently.
5. Do not attach large, heavy items to the handlebars, front forks, or fender. Unstable handling or slow steering response may result.

Accessories

Genuine Honda accessories have been specifically designed for and tested on this motorcycle.

Because the factory cannot test all other accessories, you are personally responsible for proper selection, installation and use of accessories. Always follow the guidelines under Loading, and these:

1. Carefully inspect the accessory to make sure it does not obscure any lights, reduce ground clearance and banking angle or limit suspension travel, steering travel or control operation.
2. Large fork-mounted fairings or windshields, or poorly designed or improperly mounted fairings can produce aerodynamic forces that cause unstable handling. Do not install fairings that decrease cooling air flow to the engine.
3. Accessories which alter your riding position by moving hands or feet away from controls may increase reaction time in an emergency.

4. Do not add electrical equipment that will exceed the motorcycle's electrical system capacity. A blown fuse could cause a dangerous loss of lights or engine power at night or in traffic.
5. This motorcycle was not designed to pull a sidecar or trailer. Handling may be seriously impaired if so equipped.

PARTS LOCATION

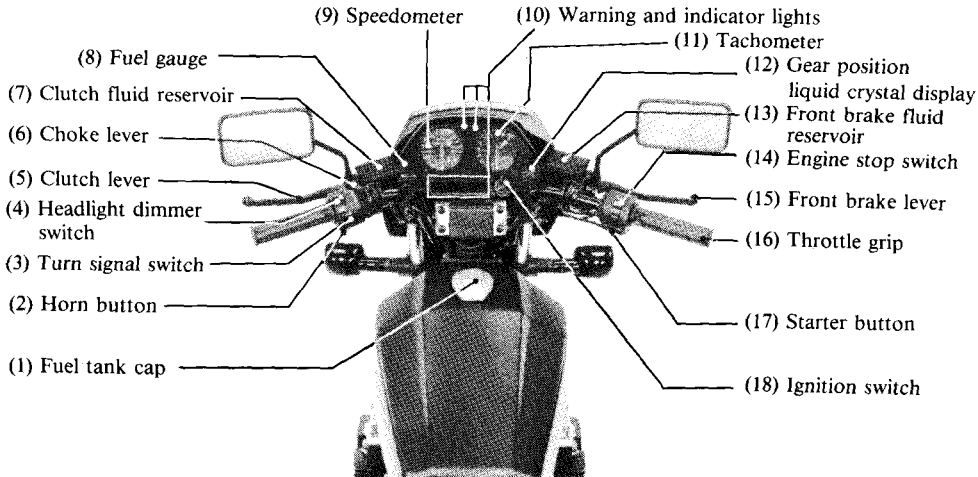

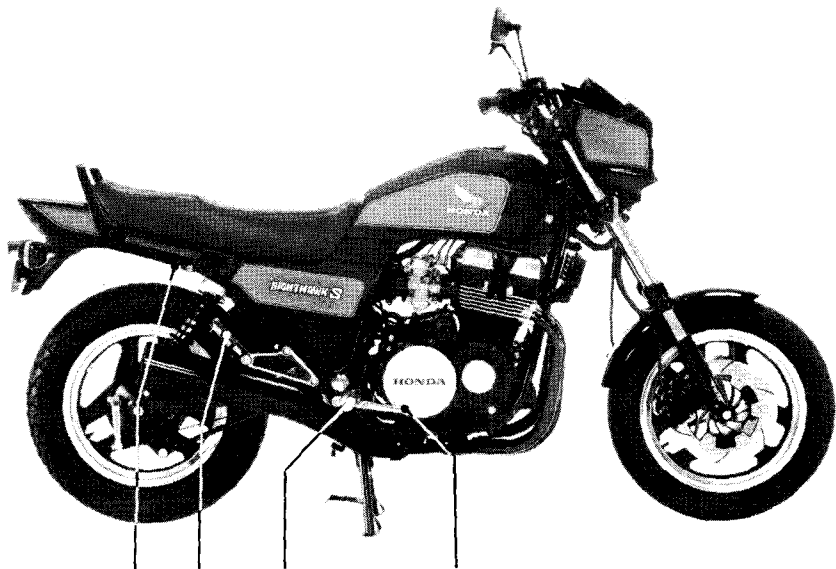

- (1) Helmet holder (2) Passenger footpeg (3) Operator footpeg (4) Rear brake pedal

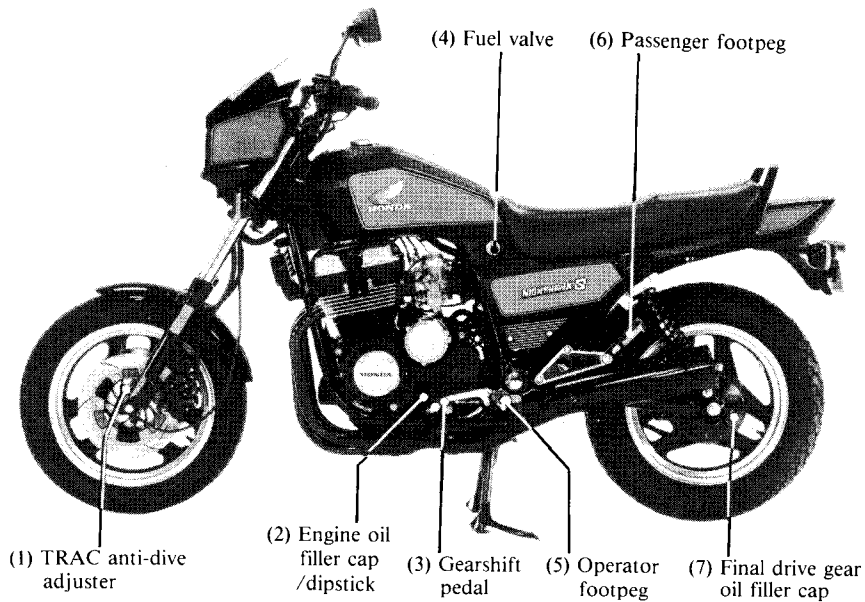

INSTRUMENTS AND INDICATORS

The indicators and warning lights are grouped around the instruments. Their functions are described in the tables on the following pages.

USA model:

Odometer and tripmeter read in miles.

Canadian model:

Odometer and tripmeter read in kilometers.

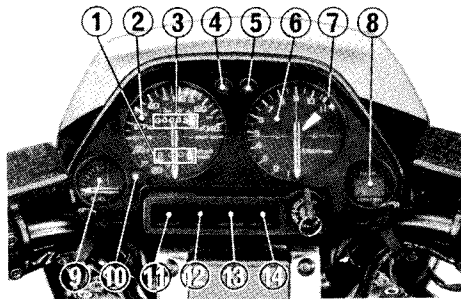

- (1) Tripmeter
- (2) Speedometer
- (3) Odometer
- (4) Left turn signal indicator
- (5) Right turn signal indicator
- (6) Tachometer
- (7) Tachometer red zone
- (8) Gear position liquid crystal display
- (9) Fuel gauge
- (10) Tripmeter reset knob
- (11) Tail/stoplight warning light
- (12) Oil pressure warning light
- (13) Highbeam indicator
- (14) Neutral indicator

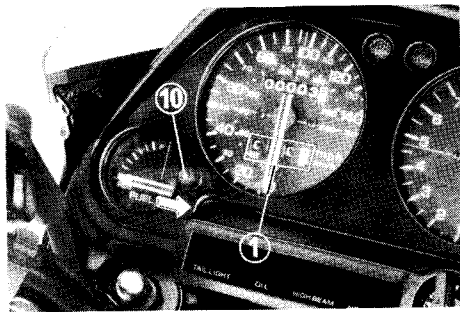

Ref. No.	Description	Function
1	Tripmeter	Shows mileage per trip.
2	Speedometer	Shows riding speed.
3	Odometer	Shows accumulated mileage.
4	Left turn signal indicator (amber)	Flashes when the left turn signal operates.
5	Right turn signal indicator (amber)	Flashes when the right turn signal operates.
6	Tachometer	Shows engine rpm.
7	Tachometer red zone	<p>Never allow the tachometer needle to enter the red zone, even after the engine has been broken in.</p> <p>CAUTION:</p> <p>* The red zone indicates the maximum limits of engine speed and running the engine in the red zone will adversely affect its service life.</p>
8	Gear position liquid crystal display	The motorcycle's gear position is indicated.
9	Fuel Gauge	Shows approximate fuel supply available (see page 13).
10	Tripmeter reset knob	Resets tripmeter to zero (0). Push knob in direction shown.

Ref. No.	Description	Function
11	Tail/stoplight warning light	Lights when the tail/stoplight bulb is burned out. Should light for a few seconds and go out when the ignition switch is turned ON.
12	Oil pressur warning light	<p>Lights when engine oil pressure is below normal operating range. Should light when ignition switch is ON and engine is not running. Should go out when engine starts, except for occasional flickering at or near idling speed when the engine is warm.</p> <p>CAUTION:</p> <p><i>* Running the engine with insufficient oil pressure will cause serious engine damage.</i></p>
13	High beam indicator	Lights when headlight is on high beam.
14	Neutral indicator	Lights when transmission is in neutral.

Fuel Gauge

The fuel gauge shows the approximate fuel supply available. At F(full) there is 16 liters (4.2 US gal). When the gauge needle first points to the RES zone, there is about 2.5 liters (0.7 US gal) left in the tank. Refill the tank as soon as possible.

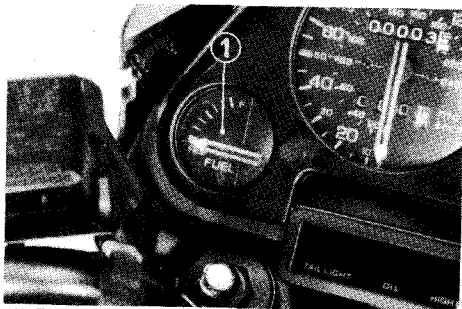

(1) Fuel gauge

MAJOR COMPONENTS (Information you need to operate this motorcycle)

CAUTION:

- * *Make sure you perform the Pre-ride Inspection (Page 34) before you ride this motorcycle.*

T.R.A.C. ANTI-DIVE ADJUSTER

The T.R.A.C. system reduces nose-dive during braking and may be adjusted to the rider's choice, independent of load or the rider's weight. The adjuster (1) is located on the left front fork and can be set to any one of your positions.

WARNING

- * *Do not position the adjuster between the numbered adjustment points.*

Adjuster position	T.R.A.C. damper force
1	Light anti-dive
2	Medium
3	Hard
4	Maximum anti-dive

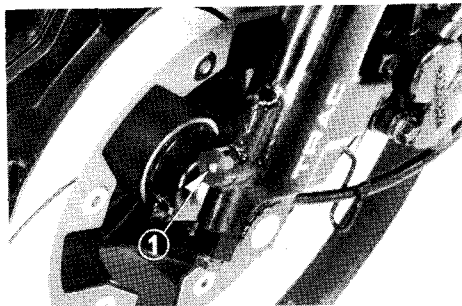

(1) Adjuster
Adjuster shown set in the "2" position.

SUSPENSION

Front Suspension

The front suspension of this motorcycle can provide the desired ride under various rider/cargo weights and riding conditions through adjustment of the air pressure within the fork tubes. The recommended pressure under normal riding conditions is 0–6 psi (0–40 kPa, 0–0.4 kg/cm²). Low air pressure settings provide a softer ride and are for light loads and smooth road conditions. High air pressure settings provide a firmer ride and are for heavy loads and rough road conditions. Check and adjust air pressure when the front fork tubes are cold before riding.

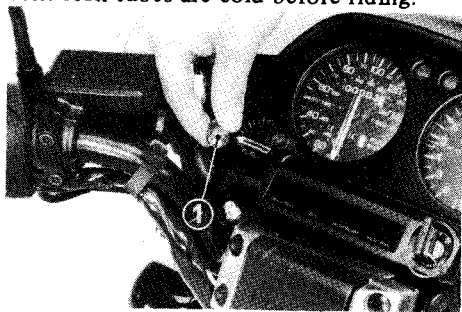

(1) Valve cap

1. Place the motorcycle on its center stand. Do not use the side stand or you will get false pressure readings.
2. Remove the front fork air valve caps (1).
3. Check the air pressure using a pressure gauge.

NOTE:

- * Some pressure will be lost when removing the gauge from the valve. Determine the amount of loss and compensate accordingly.
4. Add air to the recommended pressure. Be certain to adjust both front forks to the same air pressure.

NOTE:

- * Do not exceed the recommended air pressure or the ride will be harsh and uncomfortable.

Rear Shock Absorbers

This motorcycle has shock absorbers with two adjustable functions to provide the desired ride with various rider/cargo weights.

The spring adjuster (1) adjusts spring preload for changes in rider/cargo weight.

The rebound damping adjuster (2) adjusts damping to provide the desired ride (soft to firm) under various rider/cargo weights and riding conditions.

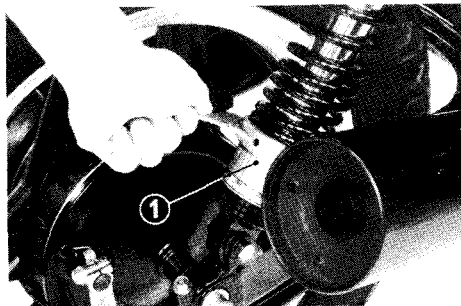

(1) Spring adjuster

WARNING

** Be careful not to touch hot mufflers while adjusting the shock absorbers.*

Adjust spring preload first, using the tool kit hook spanner to rotate the spring adjuster (1). Position 1 is for light loads and positions 2 to 5 progressively increase preload for heavier loads.

After adjusting preload, rotate the rebound damping adjuster (2) by hand to select one of the four positions.

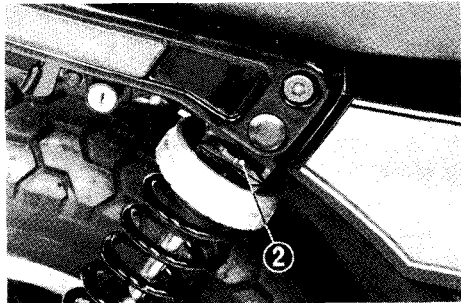

(2) Damping adjuster

NOTE:

- * Be sure to adjust both shock absorbers to the same positions.

Recommended Rear Suspension Adjustment:

REBOUND DAMPING ADJUSTER	SPRING ADJUSTER	CONDITIONS	
		RIDERS/LOAD	RIDING CONDITIONS
I	1 or 2	One	Highways
II	1 or 2	One	Around town
III	2 or 3	One	Winding road
II	3 to 5	One/Two	Highways
III	3 to 5	One/Two or carrying load	Around town
III	4 to 5	One/Two or carrying load	Winding road

BRAKES

Front Brake

This motorcycle has hydraulic disc front brakes. As the brake pads wear, brake fluid level drops, automatically compensating for wear.

There are no adjustments to perform, but fluid level and pad wear must be inspected periodically. The system must be inspected frequently to ensure there are no fluid leaks.

If the brake lever free travel becomes excessive and the brake pads are not worn beyond the recommended limit there is probably air in the brake system and it must be bled out. See your authorized Honda dealer for this service.

Brake Fluid Level:

WARNING

** Brake fluid may cause irritation. Avoid contact with skin or eyes. In case of contact, flush thoroughly with water and call a doctor if your eyes were exposed.*

Whenever the level is near the lower level mark (3) on the reservoir, fluid must be added. Remove the screws (1), reservoir cover (2), and diaphragm. Fill the reservoir with DOT 3 or 4 BRAKE FLUID from a sealed container up to the upper level mark (4). Reinstall the diaphragm and cover (2). Tighten the screws (1) securely.

CAUTION:

** When adding brake fluid be sure the reservoir is horizontal before the cover is removed or brake fluid may spill out.*

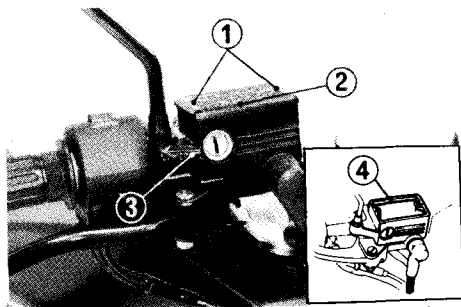

(1) Screws
(2) Reservoir cover
(3) Lower level mark
(4) Upper level mark

- * Use DOT 3 or 4 brake fluid from a sealed container.
- * Handle brake fluid with care because it can damage paint and instrument lenses.
- * Never allow contaminants (dirt, water, etc.) to enter the brake fluid reservoir.

Other Checks:

Make sure there are no fluid leaks. Check for deterioration or cracks in the hoses and fittings.

Rear Brake

Adjustment:

1. Place the motorcycle on its center stand.
2. The stopper bolt (1) is provided to allow adjustment of the pedal height. To adjust the pedal height, loosen the lock nut (2) and turn the stopper bolt. Tighten the lock nut.
3. Measure the distance the rear brake pedal (3) moves before the brake starts to take hold.

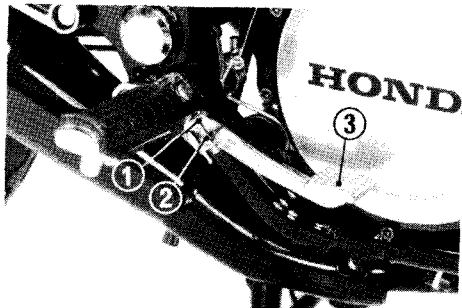

- (1) Stopper bolt (3) Rear brake pedal
(2) Lock nut

Free play should be 20–30 mm (3/4–1-1/4 in). If adjustment is necessary, turn the rear brake adjusting nut (4).

NOTE:

- * Make sure the cut-out on the adjusting nut is seated on the brake arm pin.
- * If proper adjustment cannot be obtained by this method, see your authorized Honda dealer.

4. Apply the brake several times and check for free wheel rotation when released.

Other Checks:

Make sure the brake rod, brake arm, spring and fasteners are in good condition.

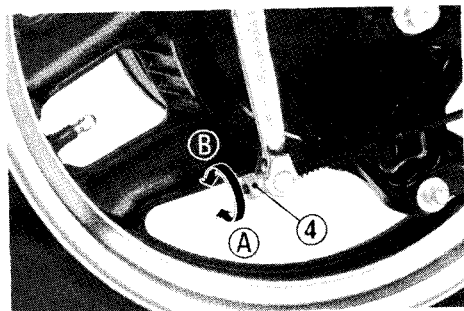

(4) Adjusting nut (A) Decrease free play
(B) Increase free play

CLUTCH

This motorcycle has a hydraulically activated clutch. There are no adjustments to perform but the clutch system must be inspected periodically for fluid level and leakage. If the control lever free play becomes excessive and the motorcycle creeps or stalls when shifted into gear, or if the clutch slips, causing acceleration to lag behind engine speed, there is probably air in the clutch system and it must be bled out. See your authorized Honda dealer for this service.

Fluid Level:

Check that the fluid level is above the lower level mark (1). If the fluid level is near the lower level mark,, it indicates fluid leakage. See your authorized Honda dealer.

Other Checks:

Make sure there are no fluid leaks. Check for deterioration or cracks in the hose and fittings.

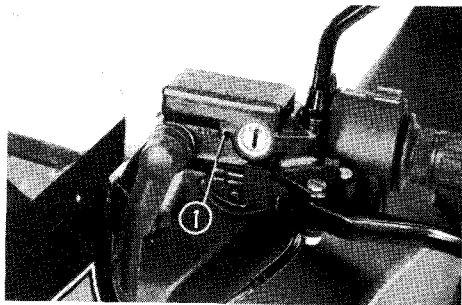

(1) Lower level mark

FUEL

Manual Fuel Valve

The manual fuel valve (1) is under the left side of the fuel tank. Set it to ON for normal operation or RES when you start to run out of the main fuel supply. The OFF setting is only for long term storage or servicing of fuel system components.

Automatic Fuel ON-OFF

With the fuel valve set to ON (or RES) fuel flows to the carburetors only when the engine is being started or is running. A diaphragm shuts off fuel flow when the engine is turned off.

Reserve Fuel

When the main fuel supply is gone, turn the fuel valve to RES. The reserve fuel supply is 2.5 l (0.7 US gal) so refill the tank as soon as possible then switch the valve back to ON.

WARNING

- * *Know how to operate the fuel valve while riding the motorcycle. You may avoid a sudden stop in traffic.*

NOTE:

- * Do not operate the machine with the fuel valve in the RES position after refueling. You may run out of fuel, with no reserve.

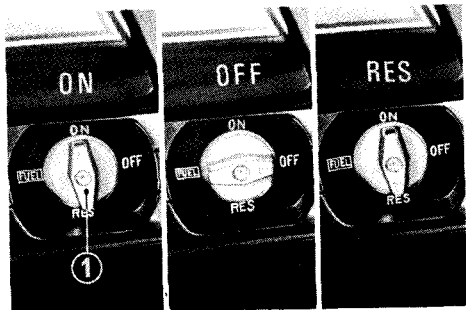

(1) Fuel valve in normal operating position

Fuel Tank

Fuel tank capacity is 16.0 ℓ (4.2 US gal) including 2.5 ℓ (0.7 US gal) in the reserve supply.

To open the fuel tank cap (1), insert the ignition key (2) and turn it clockwise. The cap is hinged and will lift up. Any automotive gasoline with a pump octane number ($\frac{R + M}{2}$) of 86 or higher

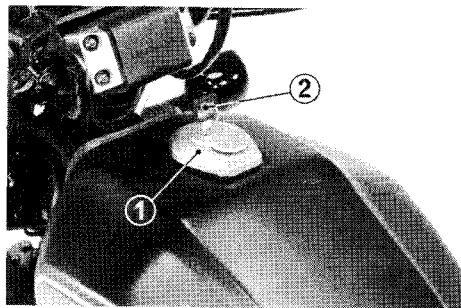

- (1) Fuel tank cap
- (2) Ignition key

or a research octane number of 91 or higher may be used. If “knocking” or “pinging” occurs, try a different brand of gasoline or a higher octane grade.

To close the fuel tank cap, press the cap into the filler neck until it snaps closed; the fuel tank cap locks automatically. Remove the key.

WARNING

- * *Gasoline is extremely flammable and is explosive under certain conditions. Refuel in a well-ventilated area with the engine stopped. Do not smoke or allow flames or sparks in the area where the motorcycle is refueled or where gasoline is stored.*
- * *Do not overfill the tank (there should be no fuel in the filler neck). After refueling, make sure the fuel cap is closed securely.*

ENGINE OIL

Engine Oil Level Check

Check the engine oil level each day before riding the motorcycle.

The level must be maintained between the upper (1) and lower (2) level marks on the dipstick (3).

1. Start the engine and let it idle for a few minutes. Make sure the red oil pressure warning light goes off. If the light remains on, stop the engine immediately.
2. Stop the engine and put the motorcycle on its center stand on level ground.
3. After a few minutes, remove the oil filler cap/dipstick (3), wipe it clean, and reinsert the dipstick without screwing it in. The oil level should be between the upper (1) and lower (2) level marks on the dipstick.
4. If required, add the specified oil up to the upper level mark. Do not overfill.
5. Reinstall the oil filler cap/dipstick. Check for oil leaks.

CAUTION:

* *Running the engine with insufficient oil can cause serious engine damage.*

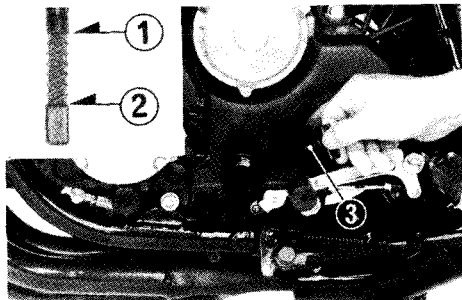

(1) Upper level mark (3) Oil filler cap/dipstick
(2) Lower level mark

Engine Oil Recommendation

USE HONDA 4-STROKE OIL OR AN EQUIVALENT

Use only high detergent, premium quality motor oil certified to meet or exceed US automobile manufacturers' requirements for Service Classification SE or SF.

Motor oils intended for Service SE or SF will show this designation on the container. The use of special oil additives is unnecessary and will only increase operating expenses.

CAUTION:

* *Engine oil is a major factor affecting the performance and service life of the engine. Non-detergent, vegetable, or castor based racing oils, are not recommended.*

Recommended Oil Viscosity

SAE 10W-40

Other viscosities shown in the chart below may be used when the average temperature in your riding area is within the indicated range.

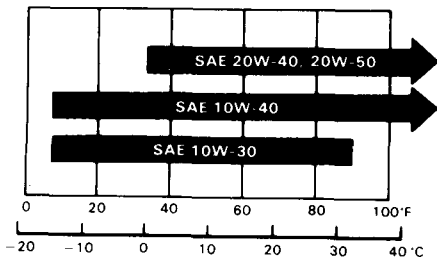

FINAL DRIVE OIL

Oil Level Check

Check the final drive oil level when specified by the maintenance schedule (page 45).

1. Place the motorcycle on its center stand on level ground.
2. Remove the oil filler cap (1).
3. Check that the oil reaches a level between the two bosses (A) on the inner housing (visible below the lower edge of the inspection hole).

NOTE:

- * If the level is low, check for leaks. Pour fresh oil through the inspection hole until it reaches a level between the two bosses (A) on the inner housing (visible below the lower edge of the inspection hole).

Recommended oil:
HYPOID GEAR OIL
SAE 80

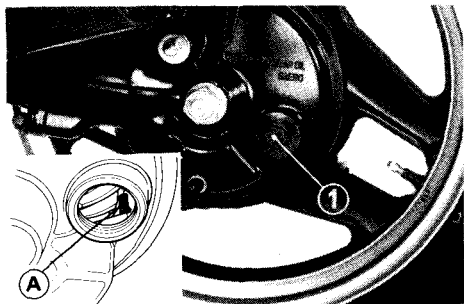

(1) Oil filler cap

(A) Two bosses

TUBELESS TIRES

This motorcycle is equipped with tubeless type tires, valves, and wheel rims. Use only tires marked "TUBELESS" and tubeless valves on rims marked "TUBELESS TIRE APPLICABLE."

Proper air pressure will provide maximum stability, riding comfort and tire life.

Check tire pressures frequently and adjust if necessary (page 2).

NOTE:

- * Tire pressure should be checked when the tires are "cold," before you ride.
- * Tubeless tires have some degree of self-sealing ability if they are punctured, and leakage is often very slow. Inspect very closely for punctures, especially if the tire is not fully inflated.

Check the tires for cuts, imbedded nails or other sharp objects. Check the rims for dents or deformation. If there is any damage, see your authorized Honda dealer for repair, replacement, and balancing.

WARNING

- * *Improper tire inflation will cause abnormal tread wear and create a safety hazard. Underinflation may result in the tire slipping on, or coming off of the rim.*
- * *Operation with excessively worn tires is hazardous and will adversely affect traction and handling.*

Replace tires before tread depth at the center of the tire reaches the limit as shown on the tire information label (page 2).

Repair:

Puncture of tubeless tires may be fixed externally for emergency. See your authorized Honda Dealer for the correct method before you encounter actual failure on the road.

WARNING

- * *Do not run at speed above 60 km/h (40 MPH) after making an external repair. It must be followed by an internal repair at the nearest Honda Dealer as soon as possible.*

Replacement:

See your authorized Honda Dealer

WARNING

- * *The use of tires other than those listed here may adversely affect handling.*
- * *Do not install tube-type tires on tubeless rims. The beads may not seat and the tires could slip on the rims, causing tire deflection.*
- * *Do not install a tube inside a tubeless tire. Excessive heat build-up may cause the tube to burst resulting in rapid tire deflection.*
- * *Proper wheel balance is necessary for safe, stable handling of the motorcycle. Do not remove or change any wheel balance weights. When wheel balancing is required, see your authorized Honda dealer. Wheel balancing is required after tire repair or replacement.*

- * *Foreign object intrusion of tire face will reduce the performance of any tire. Subsequent repair may not restore original safety factor.*
- * *Replace the tire if the sidewall is punctured or damaged. Sidewall flexing may cause repair failure and tire deflation.*

CAUTION:

- * *Do not try to remove tubeless tires without special tools and rim protectors. You may damage the rim sealing surface or disfigure the rim.*

ESSENTIAL INDIVIDUAL COMPONENTS

IGNITION SWITCH

The ignition switch (1) is below the instrument panel.

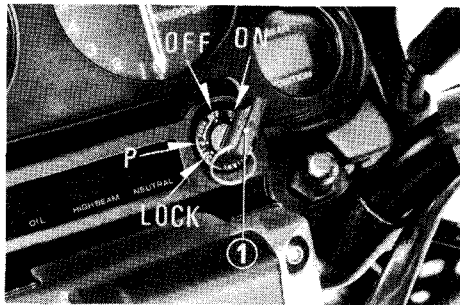

(1) Ignition switch

Key Position	Function	Key Removal
LOCK (Steering lock)	Steering is locked. Engine and lights cannot be operated.	Key can be removed.
P (Parking)	For parking the motorcycle near traffic. The taillight is on, but all other lights are off. The engine cannot be started.	Key can be removed.
OFF	Engine and lights cannot be operated.	Remove the key.
ON	Headlight, taillight and instrument lights are on and other lights can be operated. Engine can be started when the engine stop switch is at RUN.	Key can be removed.

ENGINE STOP SWITCH

The engine stop switch (1) is next to the throttle grip. In the RUN position, the engine will operate. In the OFF position the engine will not operate. This switch is intended primarily as a safety or emergency switch and should normally remain in RUN.

NOTE:

- * If your motorcycle is stopped with the ignition switch ON and the engine stop switch OFF, the headlight and taillight will still be on, resulting in battery discharge.

STARTER BUTTON

The starter button (2) is below the engine stop switch (1).

When the starter button is pressed the starter motor will crank the engine, the headlight will automatically go out, but the taillight will stay on.

See pages 35—37 for starting procedure.

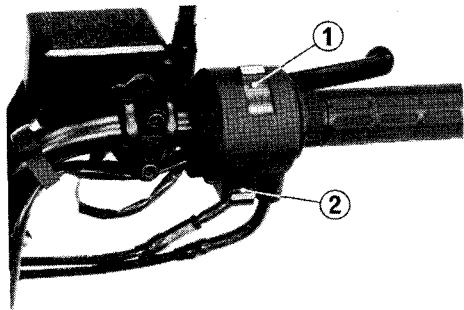

- (1) Engine stop switch
- (2) Starter button

LEFT HANDLEBAR CONTROLS

The three controls next to the left handlebar grip are:

Headlight Dimmer Switch (1)

Select HI for high beam, LO for low beam.

Turn Signal Switch (2)

Move to "L" to signal a left turn, "R" to signal a right turn. Push to turn signal off.

Horn Button (3)

Push the button to sound the horn.

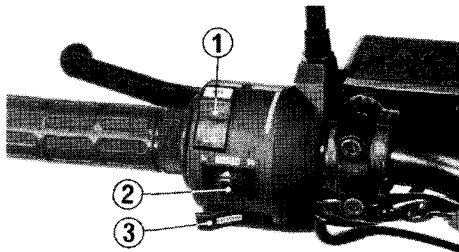

- (1) Headlight dimmer switch
- (2) Turn signal switch
- (3) Horn button

FEATURES (Not required for operation)

STEERING LOCK

To lock the steering, turn the handlebars all the way to the left, turn the key (1) to LOCK while pushing in. Remove the key.

WARNING

* Do not turn the key to LOCK while riding the motorcycle.

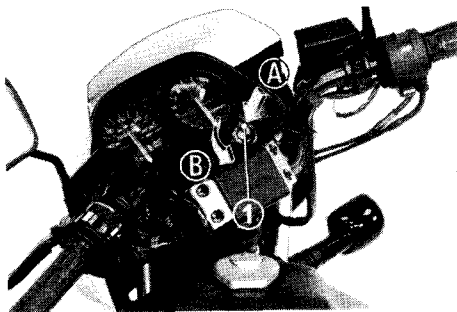

(1) Ignition key (A) Push in
(B) Turn to LOCK

HELMET HOLDER

The helmet holder (1) is on the right side under the seat. Insert the ignition key (2) and turn it counterclockwise to unlock the seat lock (3). Pull the seat lock lever (4) up and remove the seat. Hang your helmet on the helmet holder (1) and install the seat.

WARNING

* The helmet holder is designed for use while parking. Do not operate the motorcycle with a helmet attached to the holder. The helmet may interfere with the rear wheel, possibly stopping the wheel.

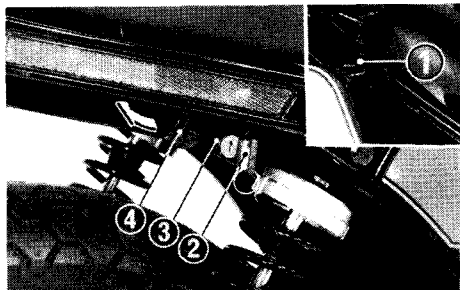

(1) Helmet holder (3) Seat lock
(2) Ignition key (4) Seat lock lever

DOCUMENT COMPARTMENT

The document compartment (1) is at the rear of the seat.

Remove the seat and open the cover.

This owner's manual and other documents should be stored in the document compartment.

When washing your motorcycle, be careful not to flood this area with water.

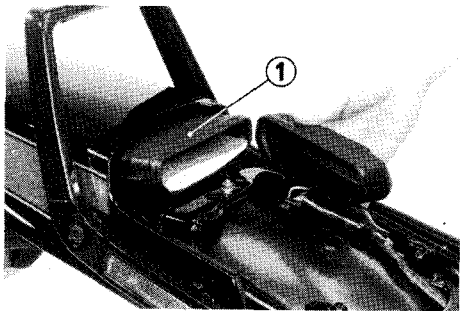

(1) Document Compartment

OPERATION

PRE-RIDE INSPECTION

WARNING

** If the Pre-ride Inspection is not performed, serious damage or an accident may result.*

Inspect your motorcycle every day before you start the engine. The items listed here will only take a few minutes, and in the long run they can save time, expense, and possibly your life.

1. Engine oil level—add engine oil if required (pages 24—25). Check for leaks.
2. Fuel level—fill fuel tank when necessary (page 23). Check for leaks.
3. Front and rear brakes—check operation; make sure there is no brake fluid leakage. Adjust free play if necessary (pages 18—20).

4. Tires—Check condition and pressure (pages 2 and 27).
5. Throttle—check for smooth opening and closing in all steering positions.
6. Lights and horn—check that headlight, tail/stoplight, turn signals, indicators and horn function properly.
7. Engine stop switch—check for proper function (page 30).

Correct any discrepancy before you ride. Contact your authorized Honda dealer for assistance if you cannot correct the problem.

STARTING THE ENGINE

WARNING

- * *Never run the engine in a closed area. The exhaust contains poisonous carbon monoxide gas.*

NOTE:

- * Do not use the electric starter for more than 5 seconds at a time. Release the starter button for approximately 10 seconds before pressing it again.
- * The electric starter will work when the transmission is in gear with the clutch disengaged.

Preparation

Make sure the transmission is in neutral, the engine stop switch is at RUN and the fuel valve is ON. Insert the key and turn the ignition switch ON.

Check that the red oil pressure warning light comes ON.

Starting Procedure

To restart a warm engine, follow the procedure for "High Air Temperature." Normal Air Temperature

10°–35°C (50°–95°F)

1. Pull the choke lever (1) back all the way to Fully open (B).
2. Start the engine, leaving the throttle closed.

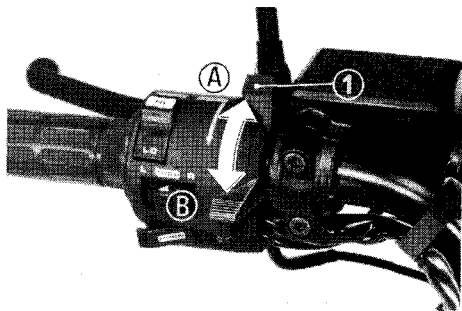

- (1) Choke lever (A) Fully closed
 (B) Fully open

NOTE:

- * Do not open the throttle when starting the engine with the choke open. This will lean the mixture, resulting in hard starting.

CAUTION:

- * *The red oil pressure warning light should go off a few seconds after the engine starts. If the light stays on, stop the engine immediately and check engine oil level. Do not operate the engine with insufficient oil pressure.*
- 3. Immediately after the engine starts, operate the choke lever (1) to keep fast idle at 1,500–2,500 rpm.
- 4. About a half minute after the engine starts, push the choke lever forward all the way to Fully Closed (A).
- 5. If idling is unstable, open the throttle slightly.

High Air Temperature

35°C (95°F) or above

1. Do not use the choke.
2. Open the throttle slightly.
3. Start the engine.

Low Air Temperature

10°C (50°F) or below

1. Follow steps 1–2 under Normal Air Temperature.
2. Warm up the engine by opening and closing the throttle slightly.
3. Continue warming up until the engine runs smoothly and responds to the throttle when the choke lever is at Fully Closed (A).

CAUTION:

- * *Snapping or first idling for more than about 5 minutes at normal air temperature may cause exhaust pipe discoloration.*
- * *Extended use of the choke may impair piston and cylinder wall lubrication.*

Flooded Engine

If the engine fails to start after repeated attempts, it may be flooded with excess fuel. To clear a flooded engine, turn the engine stop switch OFF and push the choke lever forward to Fully Closed (A). Open the throttle fully and crank the engine for 5 seconds. Wait 10 seconds, then turn the engine stop switch ON and follow the “High Air Temperature” Starting Procedure.

BREAK-IN

During initial break-in, newly machined surfaces will be in contact with each other and these surfaces will wear in quickly. Break-in maintenance at 600 miles (1,000 km) is designed to compensate for this initial minor wear. Timely performance of break-in maintenance will ensure optimum service life and performance from the engine.

The general rules are as follows:

1. Do not lug the engine with full throttle at low engine speeds. This rule is applicable not only during break-in but at all times.
2. Vary the engine speed frequently and avoid full throttle. Maximum continuous engine speed during the first 600 miles (1,000 km) must not exceed 5,000 rpm.
3. Increase the maximum continuous engine speed by 2,000 rpm between odometer readings of 600 miles (1,000 km) and 1,000 miles (1,600 km). Drive

briskly, vary speeds frequently and use full throttle for short bursts only. Do not exceed 7,000 rpm.

4. Upon reaching an odometer reading of 1,000 miles (1,600 km), you can subject the motorcycle to full throttle operation.

However, do not exceed 10,700 rpm at any time (tachometer RED ZONE limit).

CAUTION:

- * *The red zone indicates the maximum limits of engine speed and running the engine in the red zone will adversely affect its service life.*

RIDING

WARNING

- * *Review Motorcycle Safety (pages 1—6) before you ride.*
- * *Make sure the side stand is fully retracted before riding the motorcycle. If the stand is extended, it may interfere with control during a left turn.*
- * *Do not downshift when travelling at a speed that would force the engine to overrev in the next lower gear, or cause the rear wheel to lose traction.*

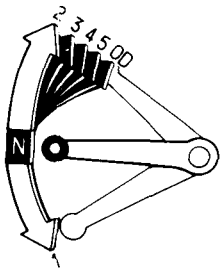

Shifting pattern

Proper shifting will provide better fuel economy. When changing gears under normal conditions, use these recommended shift points:

Shifting Up:

From 1st to 2nd:	12 mph (20 km/h)
From 2nd to 3rd:	19 mph (30 km/h)
From 3rd to 4th:	25 mph (40 km/h)
From 4th to 5th:	31 mph (50 km/h)
From 5th to OD:	37 mph (60 km/h)

Shifting Down:

From OD to 5th:	28 mph (45 km/h)
From 5th to 4th:	22 mph (35 km/h)
From 4th to 3rd:	16 mph (25 km/h)

Disengage the clutch when speed drops below 9 mph (15 km/h), when engine roughness is evident, or when engine stalling is imminent; and shift down to 1st gear for acceleration.

CAUTION:

- * *Do not shift gears without disengaging the clutch and closing the throttle. The engine and drive train could be damaged by overspeed and shock.*
- * *Do not tow the motorcycle or coast for long distances while the engine is off. The transmission will not be properly lubricated and damage may result.*
- * *Do not exceed 8,000 rpm when running the engine without a load. Serious engine damage may result.*

NOTE:

- * The battery will not charge while the engine speed is below 1,750 rpm. Avoid idling for prolonged periods, or continuous operation below 1,750 rpm.
- * Be careful when revving the engine or accelerating in 1st or 2nd gear as the engine speed will easily enter the tachometer red zone.

High Altitude Riding

When operating this motorcycle at high altitude, the air-fuel mixture becomes overly rich. Above 6,500 feet (2,000 m) driveability and performance may be reduced and fuel consumption increased. See your authorized Honda dealer for high altitude adjustments.

BRAKING

1. For normal braking, gradually apply both front and rear brakes while downshifting to suit your road speed.
2. For maximum deceleration, close the throttle and apply the front and rear brakes firmly. Disengage the clutch before the motorcycle stops.

WARNING

- * *Independent use of only the front or rear brake reduces stopping performance. Extreme braking may cause either wheel to lock, reducing control of the motorcycle.*
- * *When possible, reduce speed or brake before entering a turn; closing the throttle or braking in mid-turn may cause wheel slip. Wheel slip will reduce control of the motorcycle.*

- * *When riding in wet or rainy conditions, or on loose surfaces, the ability to maneuver and stop will be reduced. All of your actions should be smooth under these conditions. Sudden acceleration, braking or turning may cause loss of control. For your safety, exercise extreme caution when braking, accelerating or turning.*
- * *When descending a long, steep grade, use engine compression braking by downshifting, with intermittent use of both brakes. Continuous brake application can overheat the brakes and reduce their effectiveness.*

PARKING

1. After stopping the motorcycle, shift the transmission into neutral, turn the ignition switch OFF and remove the key.
2. Use the side or center stand to support the motorcycle while parked.

CAUTION:

* *Park the motorcycle on firm, level ground to prevent overturning.*

3. Lock the steering to help prevent theft (page 32).

NOTE:

* When stopping for a short time near traffic at night, the ignition switch may be turned to P and the key removed. This will turn on the taillight to make the motorcycle more visible to traffic. The battery will discharge if the ignition switch is left at P for too long a time.

ANTI-THEFT TIPS

1. Always lock the steering and never leave the key in the ignition switch. This sounds simple but people do forget.
2. Be sure the registration information for your motorcycle is accurate and current.
3. Park your motorcycle in a locked garage whenever possible.
4. Lock the steering (page 32).
5. Put your name, address, and phone number in this Owner's Manual and keep it on your motorcycle at all times. Many times stolen motorcycles are identified by information in the Owner's Manuals which are still with them.

NAME: _____

ADDRESS: _____

PHONE NO.: _____

MAINTENANCE

- The U.S. Environmental Protection Agency and California Air Resources Board (CARB) require that your motorcycle comply with applicable exhaust emissions standards during its useful life, when operated and maintained according to the instructions provided, and that motorcycles built after January 1, 1983 will comply with applicable noise emission standards for one year or 6,000 km (3,730 miles) after the time of sale to the ultimate purchaser, when operated and maintained according to the instructions provided. Compliance with the terms of the Distributor's Warranties for Honda Motorcycle Emission Control Systems is necessary in order to keep the emissions system warranty in effect. (USA only)
- When service is required, remember that your authorized Honda dealer knows your motorcycle best and is fully equipped to maintain and repair it. The scheduled maintenance and the anticipated maintenance may also be performed by a qualified service facility that normally does this kind of work; or you may perform most of the work yourself if you are mechanically qualified and have the proper tools and service data.
- These instructions are based on the assumption that the motorcycle will be used exclusively for its designed purpose. Sustained high speed operation or operation in unusually wet or dusty conditions will require more frequent service than specified in the MAINTENANCE SCHEDULE. Consult your authorized Honda dealer for recommendations applicable to your individual needs and use.

MAINTENANCE SCHEDULE

Perform the Pre-ride Inspection (page 34) at each scheduled maintenance period.

I : INSPECT AND CLEAN, ADJUST, LUBRICATE OR REPLACE IF NECESSARY

C: CLEAN R: REPLACE A: ADJUST

FREQUENCY		WHICHEVER COMES FIRST ↓	ODOMETER READING [NOTE (4)]							Refer to	
			EVERY	600 mi (1,000 km)	4,000 mi (6,400 km)	8,000 mi (12,800 km)	12,000 mi (19,200 km)	16,000 mi (25,600 km)	20,000 mi (32,000 km)		24,000 mi (38,400 km)
ITEMS											
	EMISSION RELATED ITEMS	* FUEL LINES			I	I	I	I	I	I	
* FUEL STRAINER			C	C	C	C	C	C	C		
* THROTTLE OPERATION			I	I	I	I	I	I	I		
* CARBURETOR-CHOKE				I	I	I	I	I	I		
AIR CLEANER		NOTE (1)				R		R		R	Page 51
CRANKCASE BREATHER		NOTE (2)		C	C	C	C	C	C	C	Page 52
SPARK PLUGS				R	R	R	R	R	R	R	Page 55
ENGINE OIL		YEAR	R	R	R	R	R	R	R	R	Page 53—54
ENGINE OIL FILTER		YEAR	R	R	R	R	R	R	R	R	Page 53—54
* CARBURETOR-SYNCHRONIZATION			I	I	I	I	I	I	I	I	
* CARBURETOR-IDLE SPEED			I	I	I	I	I	I	I	I	Page 56
* EVAPORATIVE EMISSION CONTROL SYSTEM		NOTE (3)				I		I		I	

FREQUENCY		WHICHEVER COMES FIRST ↓	ODOMETER READING [NOTE(4)]							Refer to
			600 mi (1,000 km)	4,000 mi (6,400 km)	8,000 mi (12,800 km)	12,000 mi (19,200 km)	16,000 mi (25,600 km)	20,000 mi (32,000 km)	24,000 mi (38,400 km)	
ITEMS		EVERY								
NON-EMISSION RELATED ITEMS	* FINAL DRIVE OIL				I		I		R	Page 57
	BATTERY	MONTH	I	I	I	I	I	I	I	Pages 66—67
	BRAKE FLUID (FRONT)	MONTH I 2 YEARS *R	I	I	I	*R	I	I	*R	Pages 18—19
	BRAKE SHOE/PAD WEAR			I	I	I	I	I	I	Page 64
	BRAKE SYSTEM		I	I	I	I	I	I	I	Pages 18—20
	* BRAKE LIGHT SWITCH		I	I	I	I	I	I	I	
	* HEADLIGHT AIM		I	I	I	I	I	I	I	
	CLUTCH FLUID	MONTH I 2 YEARS *R	I	I	I	*R	I	I	*R	Page 21
	CLUTCH SYSTEM		I	I	I	I	I	I	I	Page 21
	SIDE STAND			I	I	I	I	I	I	Page 65
	* SUSPENSION		I	I	I	I	I	I	I	
	* NUTS, BOLTS, FASTENERS		I	I	I	I	I	I	I	
	** WHEELS		I	I	I	I	I	I	I	
** STEERING HEAD BEARING		I		I		I		I		

** IN THE INTEREST OF SAFETY, WE RECOMMEND THESE ITEMS BE SERVICED ONLY BY AN AUTHORIZED HONDA DEALER.

* SHOULD BE SERVICED BY AN AUTHORIZED HONDA DEALER, UNLESS THE OWNER HAS PROPER TOOLS AND SERVICE DATA AND IS MECHANICALLY QUALIFIED. REFER TO THE OFFICIAL HONDA SHOP MANUAL.

- NOTES: (1) Service more frequently when riding in dusty areas.
 (2) Service more frequently when riding in rain, or at full throttle.
 (3) California type only.
 (4) For higher odometer reading, repeat at the frequency interval established here.

MAINTENANCE RECORD

Miles	Performed By	Odometer	Date
600			
4,000			
8,000			
12,000			
16,000			
20,000			
24,000			

- Make sure whoever performs the maintenance completes this record. All scheduled maintenance, including the 600 miles (1,000 km) break-in maintenance, is considered a normal owner operating cost and will be charged for by your dealer.
- Detailed receipts verifying the performance of required maintenance should be retained. These receipts should be transferred with the motorcycle to the new owner if the motorcycle is sold.

TOOL KIT

The tool kit is in the storage compartment behind the left side cover. To open the storage compartment cover (2), insert and turn the ignition key (1) counterclockwise. Some roadside repairs, minor adjustments and parts replacement can be performed with the tools contained in the kit.

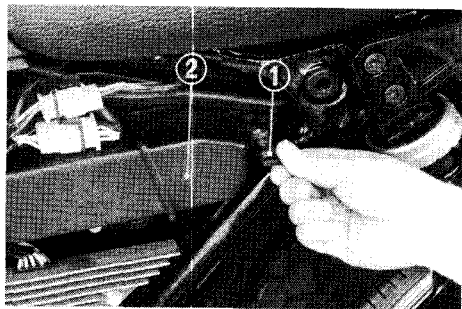

(1) Ignition key

(2) Storage compartment cover

- 8 mm open end wrench
- 10 x 12 mm open end wrench
- 14 x 17 mm open end wrench
- Pliers
- No. 4 Screw driver
- No. 2 Plus minus driver
- Screwdriver grip
- 12 mm box end wrench
- 22 mm box end wrench
- 27 mm box end wrench
- 10 x 12 mm box end wrench
- Spark plug wrench
- Feeler gauge 0.7 mm
- Tool bag
- Pin spanner
- 5 mm hex. wrench
- 6 mm hex. wrench

SERIAL NUMBERS

The frame and engine serial numbers are required when registering your motorcycle. They may also be required by your dealer when ordering replacement parts. Record the numbers here for your reference.

VIN _____

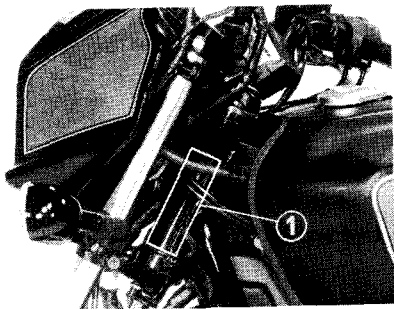

(1) VIN

The VIN, Vehicle Identification Number (1), is on the Safety Certification Label affixed to the left side of the steering head. The frame number (2) is stamped on the right side of the steering head.

FRAME NO. _____

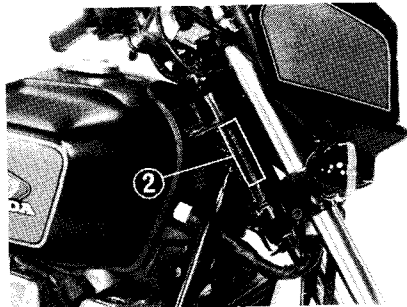

(2) Frame number

The engine number (3) is stamped on top of the crankcase.

ENGINE NO. _____

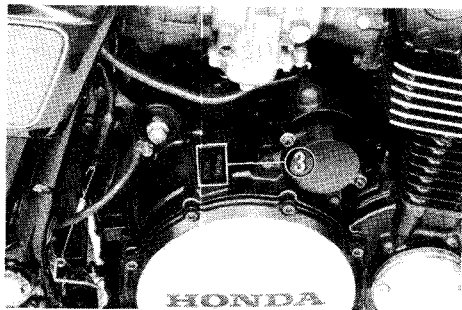

(3) Engine number

COLOR LABEL

The color label (4) is attached to the down tube under the right side cover. It is helpful when ordering replacement parts. Record the color here for your reference.

COLOR _____

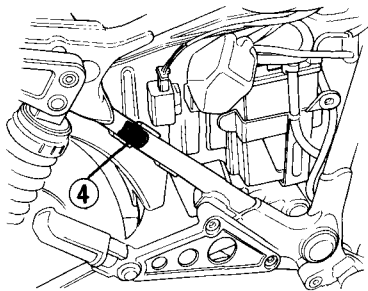

(4) Color label

MAINTENANCE PRECAUTIONS

WARNING

- * *If your motorcycle is overturned or involved in a collision, inspect control levers, clutch and brake hoses and reservoirs, calipers, accessories, and other vital parts for damage. Do not ride the motorcycle if damage impairs safe operation. Have your Honda dealer inspect the major components including frame, suspension and steering parts, for misalignment and damage that you may not be able to detect.*
- * *Stop the engine and support the motorcycle securely on a level surface before performing any maintenance.*
- * *Use new, genuine Honda parts or their equivalent for maintenance and repair. Parts which are not of equivalent quality may impair the safety of your motorcycle and the effective operation of the emission control systems.*

The Vehicle Emission Control Information label is attached to the inside of the right side cover. (USA ONLY).

The Vacuum Hose Routing label is attached to the inside of the right side cover. (California ONLY)

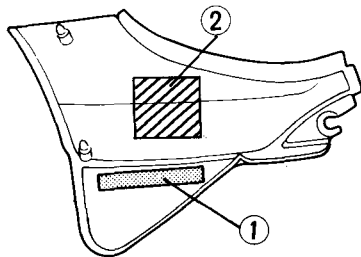

- (1) Vehicle Emission Control Information label
- (2) Vacuum Hose Routing label