



**OWNER'S MANUAL
USO E MANUTENZIONE
MANUAL DEL PROPIETARIO**

CBF250



Honda CBF250

OWNER'S MANUAL

USO E MANUTENZIONE

MANUAL DEL PROPIETARIO

IMPORTANT INFORMATION

- **OPERATOR AND PASSENGER**

This motorcycle is designed to carry the operator and one passenger. Never exceed the maximum weight capacity as shown on the accessories and loading label.

- **ON-ROAD USE**

This motorcycle is designed to be used only on the road.

- **READ THIS OWNER'S MANUAL CAREFULLY**

Pay special attention to the safety messages that appear throughout the manual. These messages are fully explained in the "A Few Words About Safety" section which appears before the Contents page.

This manual should be considered a permanent part of the motorcycle and should remain with the motorcycle when resold.

Honda CBF250 OWNER'S MANUAL

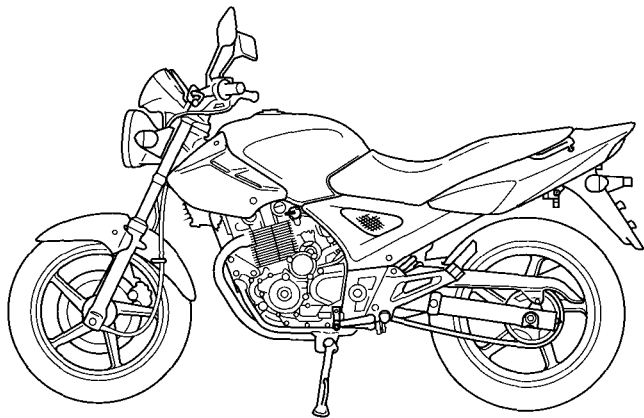

All information in this publication is based on the latest production information available at the time of approval for printing. Honda Motor Co.,Ltd. reserves the right to make changes at any time without notice and without incurring any obligation.

No part of this publication may be reproduced without written permission.

WELCOME

The motorcycle presents you a challenge to master the machine, a challenge to adventure. You ride through the wind, linked to the road by a vehicle that responds to your commands as no other does. Unlike an automobile, there is no metal cage around you. Like an airplane, a pre-ride inspection and regular maintenance are essential to your safety. Your reward is freedom.

To meet the challenges safely, and to enjoy the adventure fully, you should become thoroughly familiar with this owner's manual **BEFORE YOU RIDE THE MOTORCYCLE**.

As you read this manual, you will find information that is preceded by a **NOTICE** symbol. This information is intended to help you avoid damage to your motorcycle, other property, or the environment.

When service is required, remember that your Honda dealer knows your motorcycle best. If you have the required mechanical "know-how" and tools, your dealer can supply you with an official Honda Service Manual to help you perform many maintenance and repair tasks.

Pleasant riding, and thank you for choosing a Honda !

- The following codes in this manual indicate each country.
- The illustrations herein are based on the ED type.

E	UK
ED	European direct sales
EK	Ireland
U	Australia New Zealand

- The specifications may vary with each locale.

A FEW WORDS ABOUT SAFETY

Your safety, and the safety of others, is very important. And operating this motorcycle safely is an important responsibility.

To help you make informed decisions about safety, we have provided operating procedures and other information on labels and in this manual. This information alerts you to potential hazards that could hurt you or others.

Of course, it is not practical or possible to warn you about all hazards associated with operating or maintaining a motorcycle. You must use your own good judgment.

You will find important safety information in a variety of forms, including:

- **Safety Labels** — on the motorcycle.
- **Safety Messages** — preceded by a safety alert symbol  and one of three signal words: **DANGER, WARNING, or CAUTION.**

These signal words mean:

⚠ DANGER

You **WILL** be **KILLED** or **SERIOUSLY HURT** if you don't follow instructions.

⚠ WARNING

You **CAN** be **KILLED** or **SERIOUSLY HURT** if you don't follow instructions.

⚠ CAUTION

You **CAN** be **HURT** if you don't follow instructions.

- **Safety Headings** — such as *Important Safety Reminders* or *Important Safety Precautions*.
- **Safety Section** — such as *Motorcycle Safety*.
- **Instructions** — how to use this motorcycle correctly and safely.

This entire manual is filled with important safety information — please read it carefully.

OPERATION

page

- 1 MOTORCYCLE SAFETY**
- 1 IMPORTANT SAFETY INFORMATION
- 2 PROTECTIVE APPAREL
- 4 LOAD LIMITS AND GUIDELINES

8 PARTS LOCATION

- 11 INSTRUMENTS AND INDICATORS

19 MAJOR COMPONENTS

(Information you need to operate this motorcycle)

- 19 BRAKES
- 23 CLUTCH
- 25 FUEL
- 29 ENGINE OIL
- 30 TUBELESS TYRES

page

- 36 ESSENTIAL INDIVIDUAL COMPONENTS**
- 36 IGNITION SWITCH
- 37 KEYS
- 38 RIGHT HANDLEBAR CONTROLS
- 39 LEFT HANDLEBAR CONTROLS

page

40 FEATURES

(Not required for operation)

- 40 STEERING LOCK
- 41 HELMET HOLDER
- 42 SEAT
- 43 DOCUMENT BAG
- 44 LEFT SIDE COVER
- 45 HEADLIGHT AIM VERTICAL
ADJUSTMENT

page

46 OPERATION

- 46 PRE-RIDE INSPECTION
- 48 STARTING THE ENGINE
- 52 RUNNING-IN
- 53 RIDING
- 54 BRAKING
- 55 PARKING
- 56 ANTI-THEFT TIPS

MAINTENANCE

page

57 MAINTENANCE

- 57 THE IMPORTANCE OF MAINTENANCE
- 58 MAINTENANCE SAFETY
- 59 SAFETY PRECAUTIONS
- 60 MAINTENANCE SCHEDULE
- 63 TOOL KIT
- 64 SERIAL NUMBERS
- 65 COLOUR LABEL
- 66 AIR CLEANER
- 67 CRANKCASE BREATHER
- 68 ENGINE OIL
- 74 SPARK PLUG
- 76 THROTTLE OPERATION
- 77 IDLE SPEED
- 78 DRIVE CHAIN
- 84 FRONT AND REAR SUSPENSION INSPECTION
- 85 SIDE STAND
- 86 WHEEL REMOVAL
- 91 BRAKE PAD WEAR

page

- 92 BRAKE SHOE WEAR
- 93 BATTERY
- 95 FUSE REPLACEMENT
- 98 BRAKELIGHT SWITCH ADJUSTMENT
- 99 BULB REPLACEMENT

105 CLEANING

108 STORAGE GUIDE

- 108 STORAGE
- 110 REMOVAL FROM STORAGE

111 SPECIFICATIONS

115 CATALYTIC CONVERTER

116 NOISE CONTROL SYSTEM (AUSTRALIA ONLY)

MOTORCYCLE SAFETY

IMPORTANT SAFETY INFORMATION

Your motorcycle can provide many years of service and pleasure * if you take responsibility for your own safety and understand the challenges that you can meet on the road.

There is much that you can do to protect yourself when you ride. You'll find many helpful recommendations throughout this manual. Following are a few that we consider most important.

Always Wear a Helmet

It's a proven fact: helmets significantly reduce the number and severity of head injuries. So always wear an approved motorcycle helmet and make sure your passenger does the same. We also recommend that you wear eye protection, sturdy boots, gloves, and other protective gear (page 2).

Make Yourself Easy to See

Some drivers do not see motorcycles because they are not looking for them. To make yourself more visible, wear bright reflective clothing, position yourself so other drivers can see you, signal before turning or changing lanes, and use your horn when it will help others notice you.

Ride Within Your Limits

Pushing the limits is another major cause of motorcycle accidents. Never ride beyond your personal abilities or faster than conditions warrant. Remember that alcohol, drugs, fatigue and inattention can significantly reduce your ability to make good judgements and ride safely.

Don't Drink and Ride

Alcohol and riding don't mix. Even one drink can reduce your ability to respond to changing conditions, and your reaction time gets worse with every additional drink. So don't drink and ride, and don't let your friends drink and ride either.

Keep Your Bike in Safe Condition

For safe riding, it's important to inspect your motorcycle before every ride and perform all recommended maintenance. Never exceed load limits, and only use accessories that have been approved by Honda for this motorcycle. See page 4 for more details.

PROTECTIVE APPAREL

For your safety, we strongly recommend that you always wear an approved motorcycle helmet, eye protection, boots, gloves, long pants, and a long-sleeved shirt or jacket whenever you ride. Although complete protection is not possible, wearing proper gear can reduce the chance of injury when you ride.

Following are suggestions to help you choose proper gear.

⚠ WARNING

Not wearing a helmet increases the chance of serious injury or death in a crash.

Be sure you and your passenger always wear a helmet, eye protection and other protective apparel when you ride.

Helmets and Eye Protection

Your helmet is your most important piece of riding gear because it offers the best protection against head injuries. A helmet should fit your head comfortably and securely. A bright-coloured helmet can make you more noticeable in traffic, as can reflective strips.

An open-face helmet offers some protection, but a full-face helmet offers more. Always wear a face shield or goggles to protect your eyes and help your vision.

Additional Riding Gear

In addition to a helmet and eye protection, we also recommend:

- Sturdy boots with non-slip soles to help protect your feet and ankles.
- Leather gloves to keep your hands warm and help prevent blisters, cuts, burns and bruises.
- A motorcycle riding suit or jacket for comfort as well as protection. Bright-coloured and reflective clothing can help make you more noticeable in traffic. Be sure to avoid loose clothes that could get caught on any part of your motorcycle.

LOAD LIMITS AND GUIDELINES

Your motorcycle has been designed to carry you and one passenger. When you carry a passenger, you may feel some difference during acceleration and braking. But so long as you keep your motorcycle well-maintained, with good tyres and brakes, you can safely carry loads within the given limits and guidelines.

However, exceeding the weight limit or carrying an unbalanced load can seriously affect your motorcycle's handling, braking and stability. Non-Honda accessories, improper modifications, and poor maintenance can also reduce your safety margin.

The following pages give more specific information on loading, accessories and modifications.

Loading

How much weight you put on your motorcycle, and how you load it, are important to your safety. Anytime you ride with a passenger or cargo you should be aware of the following information.

WARNING

Overloading or improper loading can cause a crash and you can be seriously hurt or killed.

Follow all load limits and other loading guidelines in this manual.

Load Limits

Following are the load limits for your motorcycle:

Maximum weight capacity:

175 kg (386 lbs)

Includes the weight of the rider, passenger, all cargo and all accessories

Maximum cargo weight:

14 kg (31 lbs)

The weight of added accessories will reduce the maximum cargo weight you can carry.

Loading Guidelines

Your motorcycle is primarily intended for transporting you and a passenger. You may wish to secure a jacket or other small items to the seat when you are not riding with a passenger.

If you wish to carry more cargo, check with your Honda dealer for advice, and be sure to read the information regarding accessories on page 7 .

Improperly loading your motorcycle can affect its stability and handling. Even if your motorcycle is properly loaded, you should ride at reduced speeds and never exceed 130 km/h (80 mph) when carrying cargo.

Follow these guidelines whenever you carry a passenger or cargo:

- Check that both tyres are properly inflated (page 30).
- To prevent loose items from creating a hazard, make sure that all cargo is securely tied down before you ride away.
- Place cargo weight as close to the center of the motorcycle as possible.
- Balance cargo weight evenly on both sides.

Accessories and Modifications

Modifying your motorcycle or using non-Honda accessories can make your motorcycle unsafe. Before you consider making any modifications or adding an accessory, be sure to read the following information.

WARNING

Improper accessories or modifications can cause a crash in which you can be seriously hurt or killed.

Follow all instructions in this owner's manual regarding accessories and modifications.

Accessories

We strongly recommend that you use only genuine Honda accessories that have been specifically designed and tested for your motorcycle. Because Honda cannot test all other accessories, you must be personally responsible for proper selection, installation and use of non-Honda accessories. Check with your dealer for assistance and always follow these guidelines:

- Make sure the accessory does not reduce ground clearance and lean angle, limit suspension travel or steering travel, alter your riding position or interfere with operating any controls.
- Be sure electrical equipment does not exceed the motorcycle's electrical system capacity (page 114). A blown fuse can cause a loss of lights or engine power.

- Do not pull a trailer or sidecar with your motorcycle. This motorcycle was not designed for these attachments, and their use can seriously impair your motorcycle's handling.

Modifications

We strongly advise you not to remove any original equipment or modify your motorcycle in any way that would change its design or operation. Such changes could seriously impair your motorcycle's handling, stability and braking, making it unsafe to ride.

Removing or modifying your lights, mufflers, emission control system or other equipment can also make your motorcycle illegal.

PARTS LOCATION

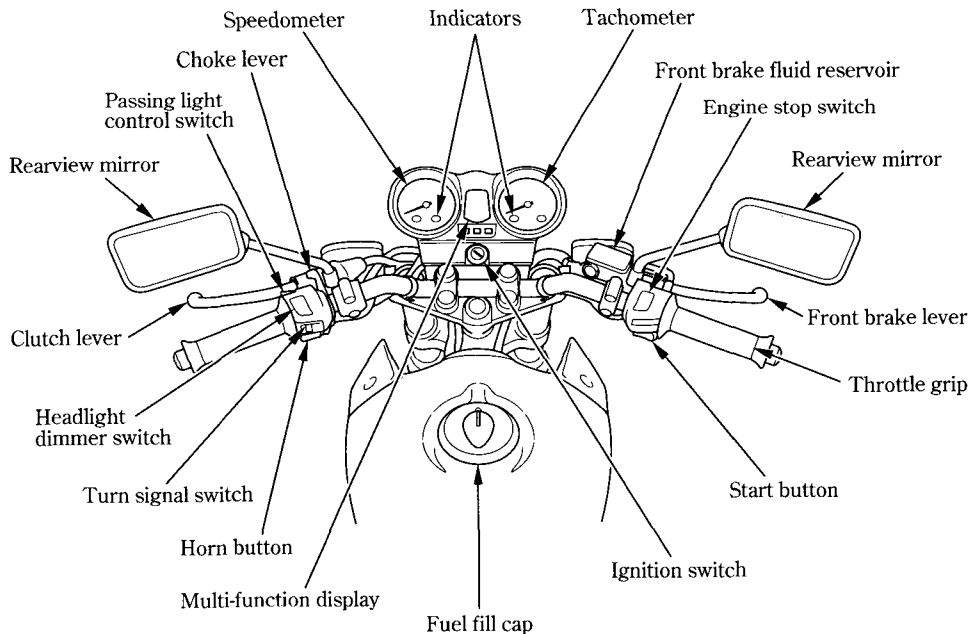

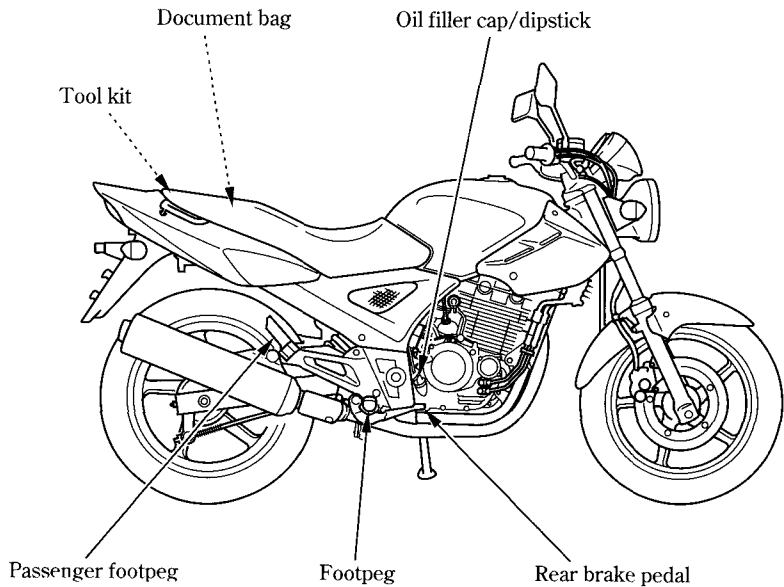

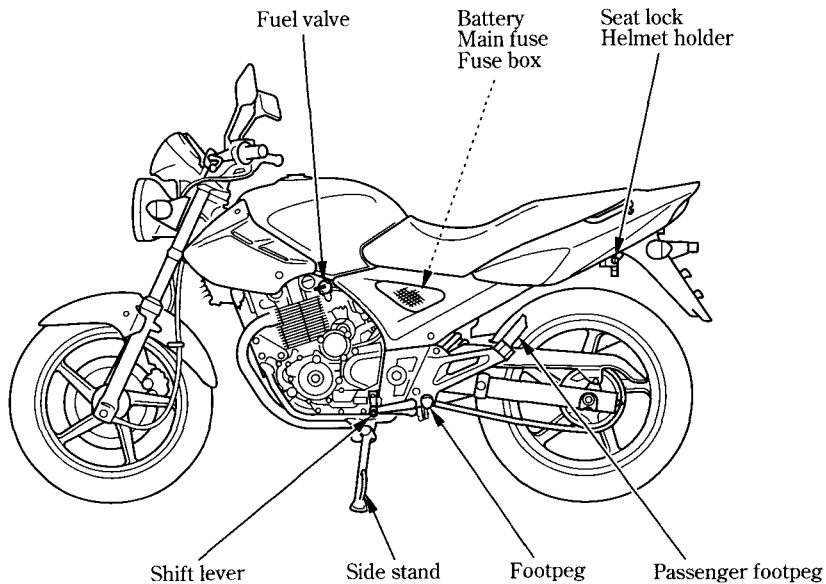

INSTRUMENTS AND INDICATORS

The indicators are contained in the instrument panel. Their functions are described in the tables on the following pages.

- (1) Speedometer
- (2) Multi-function display
- (3) Tachometer
- (4) Tachometer red zone
- (5) Right turn signal indicator
- (6) Neutral indicator
- (7) RESET button
- (8) MINUTE button
- (9) HOUR button
- (10) High beam indicator
- (11) Left turn signal indicator

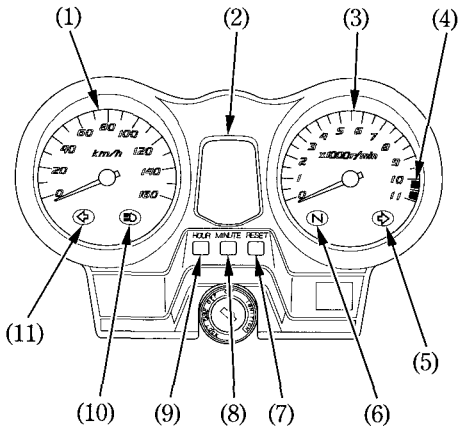

(Ref.No.) Description	Function								
(1) Speedometer	<p>Shows riding speed.</p> <p>This shows your speed in kilometers per hour (km/h) and/or miles per hour (mph) depending on the type.</p> <p>The speedometer needle will swing to the maximum scale on the dial once when the ignition switch is turned ON.</p>								
(2) Multi-function display	<p>The display includes the following functions;</p> <table border="1" data-bbox="207 467 1348 743"> <tbody> <tr> <td data-bbox="207 467 575 536">Digital clock</td> <td data-bbox="575 467 1348 536">Shows hour and minute (page 16).</td> </tr> <tr> <td data-bbox="207 536 575 606">Fuel gauge</td> <td data-bbox="575 536 1348 606">Shows approximate fuel supply available (page 18).</td> </tr> <tr> <td data-bbox="207 606 575 675">Tripmeter</td> <td data-bbox="575 606 1348 675">Shows mileage per trip (page 17).</td> </tr> <tr> <td data-bbox="207 675 575 743">Odometer</td> <td data-bbox="575 675 1348 743">Shows accumulated mileage.</td> </tr> </tbody> </table>	Digital clock	Shows hour and minute (page 16).	Fuel gauge	Shows approximate fuel supply available (page 18).	Tripmeter	Shows mileage per trip (page 17).	Odometer	Shows accumulated mileage.
Digital clock	Shows hour and minute (page 16).								
Fuel gauge	Shows approximate fuel supply available (page 18).								
Tripmeter	Shows mileage per trip (page 17).								
Odometer	Shows accumulated mileage.								

(Ref.No.) Description	Function
(3) Tachometer	Shows engine revolutions per minute. The tachometer needle will swing to the maximum scale on the dial once when the ignition switch is turned ON.
(4) Tachometer red zone	<p>Never allow the tachometer needle to enter the red zone, even after the engine has been broken in.</p> <p>NOTICE</p> <p>Running the engine beyond recommended maximum engine speed (the beginning of the tachometer red zone) can damage the engine.</p>
(5) Right turn signal indicator (green)	Flashes when the right turn signal operates.
(6) Neutral indicator (green)	Lights when the transmission is in neutral.

(Ref.No.) Description	Function
(7) RESET button	Resets the tripmeter to zero (0) (page 17). This button also used to adjust the digital clock (page 16).
(8) MINUTE button	Adjusts the minute of the digital clock (page 16).
(9) HOUR button	Adjusts the hour of the digital clock (page 16).
(10) High beam indicator (blue)	Lights when the headlight is on high beam.
(11) Left turn signal indicator (green)	Flashes when the left turn signal operates.

Initial Display

The multi-function display (1) includes the following functions:

- Digital clock
- Odometer
- Tripmeter
- Fuel gauge

When the ignition switch is turned ON, the display will temporarily show all the modes and digital segments so you can make sure the liquid crystal display is functioning properly.

The tripmeter “km” will be displayed only for ED, EK and U type.

The tripmeter “mile” will be displayed only for E type.

Both digital clock and tripmeter will reset if the battery is disconnected.

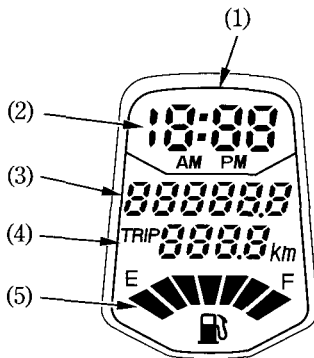

- (1) Multi-function display
- (2) Digital clock
- (3) Odometer
- (4) Tripmeter
- (5) Fuel gauge

Digital Clock

Shows hour and minute. To adjust the time, proceed as follows:

1. Turn the ignition switch ON.
2. Press and hold both the HOUR (1) and MINUTE (2) button for more than 2 seconds. The clock will be set in the adjust mode with the display flashing.
3. To set the hour, press and release the HOUR button until the desired hour and AM/PM setting are displayed.

- The time is advanced by one hour, each time the button is pushed.
- The time advances fast when the button is pushed and held.

4. To set the minute, press and release the MINUTE button until the desired minute is displayed.

The minute display will return to "00" when "60" is reached without affecting the hour display.

- The time is advanced by one minute, each time the button is pushed.
- The time advances fast when the button is pushed and held.

5. To end the adjustment, press the RESET (3) button or turn the ignition switch OFF.

The clock will be reset AM 1:00 if the battery is disconnected.

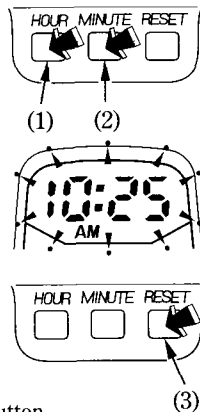

- (1) HOUR button
- (2) MINUTE button
- (3) RESET button

Tripmeter

The tripmeter shows mileage per trip.

To reset the tripmeter, press and hold the RESET button (1) for more than 2 seconds.

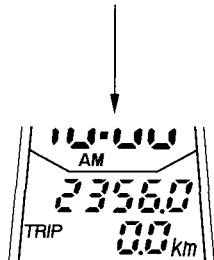
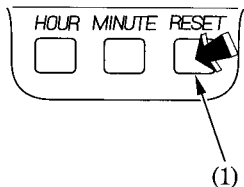

(1) RESET button

Fuel Gauge

The fuel gauge liquid crystal display (1) shows the approximate fuel supply available in a graduated display. When the segment F (2) goes on, the fuel tank capacity including reserve is:

16.0 l (4.23 US gal , 3.52 Imp gal)

When segment E (3) flashes, fuel will be low and you should refill the tank as soon as possible.

The amount of fuel left in the tank with the vehicle set upright is approximately:

2.9 l (0.77 US gal , 0.64 Imp gal)

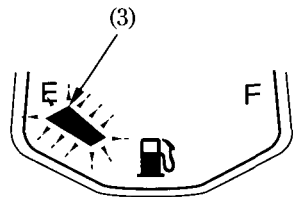
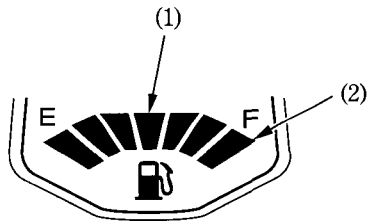

- (1) Fuel gauge liquid crystal display
- (2) Segment F
- (3) Segment E

MAJOR COMPONENTS (Information you need to operate this motorcycle)

BRAKES

Front Brake

This motorcycle has a hydraulic front disc brake.

As the brake pads wear, brake fluid level drops.

There are no adjustments to perform, but fluid level and pad wear must be inspected periodically. The system must be inspected frequently to ensure there are no fluid leaks. If the control lever free travel becomes excessive and the brake pads are not worn beyond the recommended limit (page 91), there is probably air in the brake system and it must be bled. See your Honda dealer for this service.

Front Brake Fluid Level:

With the motorcycle in an upright position, check the fluid level. It should be above the LOWER level mark (1). If the level is at or below the LOWER level mark, check the brake pads for wear (page 91).

Worn pads should be replaced. If the pads are not worn, have your brake system inspected for leaks.

The recommended brake fluid is Honda DOT 4 brake fluid from a sealed container, or an equivalent.

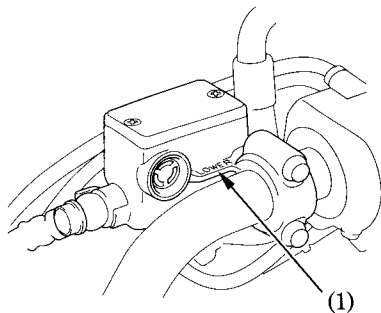

(1) LOWER level mark

Other Checks:

Make sure there are no fluid leaks. Check for deterioration or cracks in the hoses and fittings.

Rear Brake

Pedal Height Adjustment:

Place the motorcycle on its side stand.

The stopper bolt (1) is provided to allow adjustment of the pedal height. To adjust the pedal height, loosen the lock nut (2) and turn the stopper bolt. Tighten the lock nut.

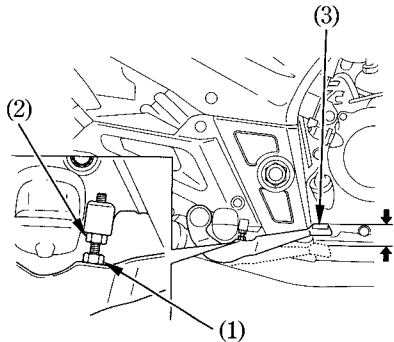

(1) Stopper bolt
(2) Lock nut

(3) Rear brake pedal

Adjustment:

1. Place the motorcycle on its side stand.
2. Measure the distance the rear brake pedal (3) moves before the brake starts to take hold.

Freeplay should be:

20 * 30 mm (0.8 * 1.2 in)

If adjustment is necessary, turn the rear brake adjusting nut (4).

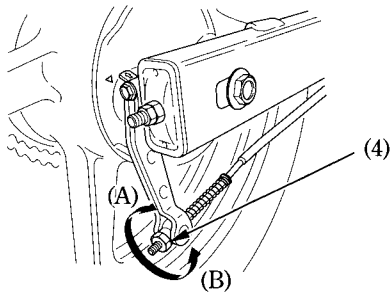

(4) Rear brake
adjusting nut

(A) Decrease freeplay
(B) Increase freeplay

3. Apply the brake several times and check for free wheel rotation after the brake pedal is released.

Make sure the cut-out on the adjusting nut is seated on the brake arm pin (5) after making final freeplay adjustment. If proper adjustment cannot be obtained by this method, see your Honda dealer.

Other Checks:

Make sure the brake rod, brake arm, spring and fasteners are in good condition.

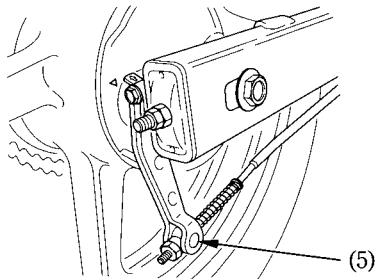

(5) Brake arm pin

CLUTCH

Clutch adjustment may be required if the motorcycle stalls when shifting into gear or tends to creep; or if the clutch slips, causing acceleration to lag behind engine speed. Minor adjustments can be made with the clutch cable adjuster (4) at the clutch lever (1).

Normal clutch lever freeplay is:
10 * 20 mm (0.4 * 0.8 in)

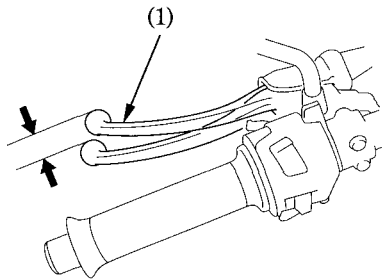

(1) Clutch lever

1. Pull back the rubber dust cover (2).
2. Loosen the lock nut (3) and turn the clutch cable adjuster. Tighten the lock nut and check the adjustment.
3. If the adjuster is threaded out near its limit or if the correct freeplay cannot be obtained, loosen the lock nut and turn in the clutch cable adjuster completely. Tighten the lock nut and install the dust cover.

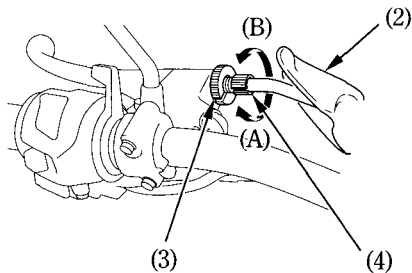

- (2) Rubber dust cover (A) Increase freeplay
(3) Lock nut (B) Decrease freeplay
(4) Clutch cable adjuster

4. Loosen the lock nut (5) at the lower end of the cable. Turn the adjusting nut (6) to obtain the specified freeplay. Tighten the lock nut and check the adjustment.
5. Start the engine, pull in the clutch lever and shift into gear. Make sure the engine does not stall and the motorcycle does not creep. Gradually release the clutch lever and open the throttle. The motorcycle should begin to move smoothly and accelerate gradually.

If proper adjustment cannot be obtained or the clutch does not work correctly, see your Honda dealer.

Other Checks:

Check the clutch cable for kinks or signs of wear that could cause sticking or failure. Lubricate the clutch cable with a commercially available cable lubricant to prevent premature wear and corrosion.

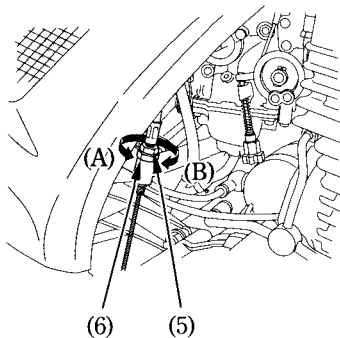

(5) Lock nut
(6) Adjusting nut

(A) Increase freeplay
(B) Decrease freeplay

FUEL

Fuel Valve

The three way fuel valve (1) is on the left side near the carburetor.

ON

With the fuel valve in the ON position, fuel will flow from the main fuel supply to the carburetor.

OFF

With the fuel valve in the OFF position, fuel cannot flow from the tank to the carburetor. Turn the valve OFF whenever the motorcycle is not in use.

RES

With the fuel valve in the RES position, fuel will flow from the reserve fuel supply to the carburetor. Use the reserve fuel only when the main supply is gone. Refill the tank as soon as possible after switching to RES.

The reserve fuel supply is:

2.5 l (0.66 US gal , 0.55 Imp gal)

Remember to check that the fuel valve is in the ON position each time you refuel. If the valve is left in the RES position, you may run out of fuel with no reserve.

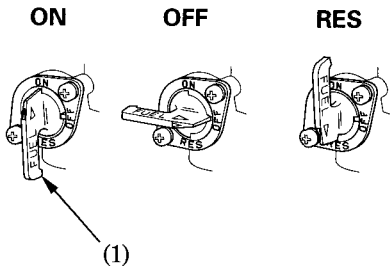

(1) Fuel valve

Fuel Tank

The fuel tank capacity including the reserve supply is:

16.0 l (4.23 US gal , 3.52 Imp gal)

To open the fuel fill cap (1), open the tank cap cover (2), insert the ignition key (3) and turn it clockwise. The fuel fill cap will pop up and can be lifted off.

Do not overfill the tank. There should be no fuel in the filler neck (4).

After refueling, to close the fuel fill cap, push the fuel fill cap into the filler neck until it snaps closed and locks. Remove the key.

⚠ WARNING

Petrol is highly flammable and explosive. You can be burned or seriously injured when handling fuel.

- Stop the engine and keep heat, sparks, and flame away.
- Refuel only outdoors.
- Wipe up spills immediately.

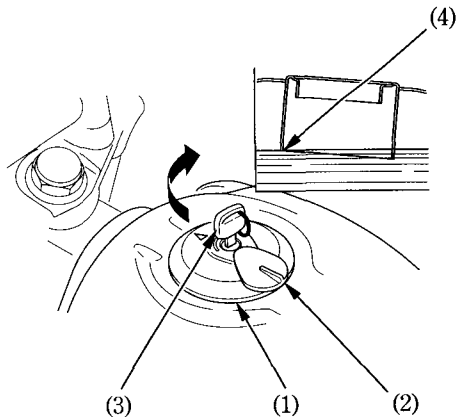

(1) Fuel fill cap
(2) Tank cap cover

(3) Ignition key
(4) Filler neck

Use unleaded petrol with a research octane number of 91 or higher.

The use of leaded petrol will cause premature damage to the catalytic converter.

NOTICE

If “spark knock” or “pinking” occurs at a steady engine speed under normal load, change brands of petrol. If spark knock or pinking persists, consult your Honda dealer. Failure to do so is considered misuse, and damage caused by misuse is not covered by Honda’s Limited Warranty.

Petrol Containing Alcohol

If you decide to use a petrol containing alcohol (gasohol), be sure it's octane rating is at least as high as that recommended by Honda. There are two types of "gasohol": one containing ethanol, and the other containing methanol. Do not use petrol that contains more than 10 % ethanol. Do not use petrol containing methanol (methyl or wood alcohol) that does not also contain cosolvents and corrosion inhibitors for methanol. Never use petrol containing more than 5 % methanol, even if it has cosolvents and corrosion inhibitors.

Fuel system damage or engine performance problems resulting from the use of fuels that contain alcohol is not covered under the warranty. Honda cannot endorse the use of fuels containing methanol since evidence of their suitability is as yet incomplete.

Before buying fuel from an unfamiliar station, try to find out if the fuel contains alcohol. If it does, confirm the type and percentage of alcohol used. If you notice any undesirable operating symptoms while using a petrol that contains alcohol, or one that you think contains alcohol, switch to a petrol that you know does not contain alcohol.

ENGINE OIL

Engine Oil Level Check

Check the engine oil level each day before riding the motorcycle.

The level must be maintained between the upper (1) and lower (2) level marks on the oil filler cap/dipstick (3).

1. Start the engine and let it idle for 3*5 minutes.
2. Stop the engine and hold the motorcycle in an upright position on firm, level ground.
3. After 2*3 minutes, remove the oil filler cap/dipstick, wipe it clean, and reinsert the oil filler cap/dipstick without screwing it in. Remove the oil filler cap/dipstick. The oil level should be between the upper and lower level marks on the oil filler cap/dipstick.
4. If required, add the specified oil (see page 68) up to the upper level mark. Do not overfill.

5. Reinstall the oil filler cap/dipstick. Check for oil leaks.

NOTICE

Running the engine with insufficient oil pressure may cause serious engine damage.

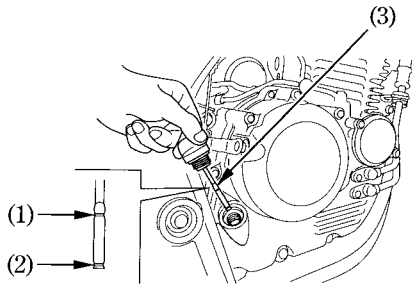

- (1) Upper level mark
- (2) Lower level mark
- (3) Oil filler cap/dipstick

TUBELESS TYRES

To safely operate your motorcycle, your tyres must be the proper type and size, in good condition with adequate tread, and correctly inflated for the load you are carrying. The following pages give more detailed information on how and when to check your air pressure, how to inspect your tyres for damage, and what to do when your tyres need to be repaired or replaced.

⚠ WARNING

Using tyres that are excessively worn or improperly inflated can cause a crash in which you can be seriously hurt or killed.

Follow all instructions in this owner's manual regarding tyre inflation and maintenance.

Air Pressure

Keeping your tyres properly inflated provides the best combination of handling, tread life and riding comfort. Generally, underinflated tyres wear unevenly, adversely affect handling, and are more likely to fail from being overheated.

Overinflated tyres make your motorcycle ride harshly, are more prone to damage from road hazards, and wear unevenly.

We recommend that you visually check your tyres before every ride and use a gauge to measure air pressure at least once a month or any time you think the tyres might be low.

Tubeless tyres have some self-sealing ability if they are punctured. However, because leakage is often very slow, you should look closely for punctures whenever a tyre is not fully inflated.

Always check air pressure when your tyres are “cold” * when the motorcycle has been parked for at least three hours. If you check air pressure when your tyres are “warm” * when the motorcycle has been ridden for even a few miles * the readings will be higher than if the tyres were “cold”. This is normal, so do not let air out of the tyres to match the recommended cold air pressures given below. If you do, the tyres will be underinflated.

The recommended “cold” tyre pressures are:

kPa (kgf/cm ² , psi)		
Driver only	Front	225 (2.25 , 33)
	Rear	225 (2.25 , 33)
Driver and one passenger	Front	225 (2.25 , 33)
	Rear	250 (2.50 , 36)

Inspection

Whenever you check the tyre pressures, you should also examine the tyre treads and sidewalls for wear, damage, and foreign objects:

Look for:

- Bumps or bulges in the side of the tyre or the tread. Replace the tyre if you find any bumps or bulges.
- Cuts, splits or cracks in the tyre. Replace the tyre if you can see fabric or cord.
- Excessive tread wear.

Also, if you hit a pothole or hard object, pull to the side of the road as soon as you safely can and carefully inspect the tyres for damage.

Tread Wear

Replace tyres before tread depth at the center of the tyre reaches the following limit:

Minimum tread depth	
Front:	1.5 mm (0.06 in)
Rear:	2.0 mm (0.08 in)

< For Germany >

German law prohibits use of tyres whose tread depth is less than 1.6 mm.

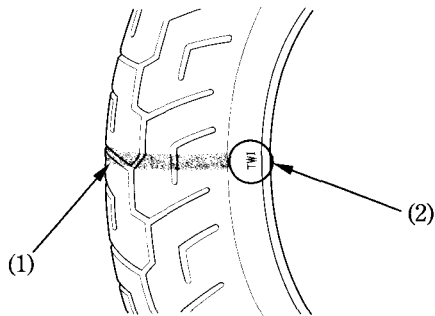

- (1) Wear indicator
- (2) Wear indicator location mark

Tyre Repair

If a tyre is punctured or damaged, you should replace it, not repair it. As discussed below, a tyre that is repaired, either temporarily or permanently, will have lower speed and performance limits than a new tyre.

A temporary repair, such as an external tubeless tyre plug, may not be safe for normal speeds and riding conditions. If a temporary or emergency repair is made to a tyre, you should ride slowly and cautiously to a dealer and have the tyre replaced. If possible, you should not carry a passenger or cargo until a new tyre is installed.

Even if a tyre is professionally repaired with a permanent internal patch plug, it will not be as good as a new tyre. You should not exceed 80 km/h (50 mph) for the first 24 hours, or 130 km/h (80 mph) at any time thereafter. In addition, you may not be able to safely carry as much weight as with a new tyre. Therefore, we strongly recommend that you replace a damaged tyre. If you choose to have a tyre repaired, be sure the wheel is balanced before you ride.

Tyre Replacement

The tyres that came on your motorcycle were designed to match the performance capabilities of your motorcycle and provide the best combination of handling, braking, durability and comfort.

WARNING

Installing improper tyres on your motorcycle can affect handling and stability. This can cause a crash in which you can be seriously hurt or killed.

Always use the size and type of tyres recommended in this owner's manual.

The recommended tyres for your motorcycle are:

Front: 100/80 * 17M/C 52S
PIRELLI
MT75

Rear: 130/70 * 17M/C 62S
PIRELLI
MT75

Type: bias-ply, tubeless

Whenever you replace a tyre, use one that is equivalent to the original and be sure the wheel is balanced after the new tyre is installed.

Important Safety Reminders

- Do not install a tube inside a tubeless tyre on this motorcycle. Excessive heat build-up can cause the tube to burst.
- Use only tubeless tyres on this motorcycle. The rims are designed for tubeless tyres, and during hard acceleration or braking, a tube-type tyre could slip on the rim and cause the tyre to rapidly deflate.

ESSENTIAL INDIVIDUAL COMPONENTS

IGNITION SWITCH

The ignition switch (1) is below the indicator panel.

The headlight and taillights will come on whenever you turn the ignition switch ON. If your motorcycle is stopped with the ignition switch ON and the engine is not running, the headlight and taillights will still be on, resulting in battery discharge.

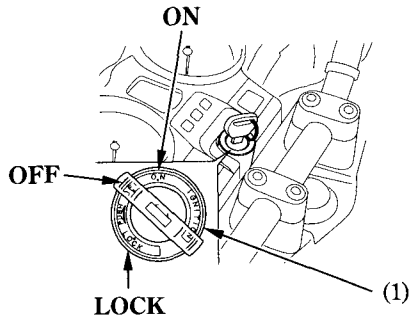

(1) Ignition switch

Key Position	Function	Key Removal
LOCK (steering lock)	Steering is locked. Engine and lights cannot be operated.	Key can be removed
OFF	Engine and lights cannot be operated.	Key can be removed
ON	Engine and lights can be operated.	Key cannot be removed

KEYS

This motorcycle has two ignition keys (1).

To reproduce keys, bring all keys and motorcycle to your Honda dealer.

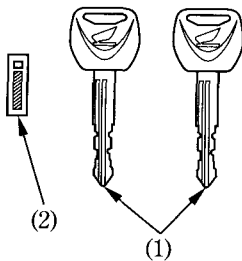

(1) Ignition keys

(2) Key number plate

RIGHT HANDLEBAR CONTROLS

Engine Stop Switch

The engine stop switch (1) is next to the throttle grip. When the switch is in the

○ (RUN) position, the engine will operate. When the switch is in the ⊗ (OFF) position, the engine will not operate. This switch is intended primarily as a safety or emergency switch and should normally remain in the ○ (RUN) position.

If your motorcycle is stopped with the ignition switch ON and the engine stop switch ⊗ (OFF), the headlight and taillight will still be on, resulting in battery discharge.

Start Button

The start button (2) is below the engine stop switch.

When the start button is pressed, the starter motor cranks the engine, the headlight will automatically go out, but the taillights will stay on. If the engine stop switch is in the ⊗ (OFF) position, the starter motor will not operate. See page 49 for the starting procedure.

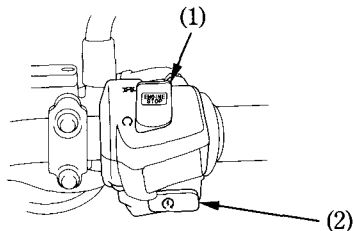



(1) Engine stop switch

(2) Start button

LEFT HANDLEBAR CONTROLS



Headlight Dimmer Switch (1)

Push the dimmer switch to  D (HI) to select high beam or to  D (LO) to select low beam.

Passing Light Control Switch (2)

When this switch is pressed, the headlight flashes on to signal approaching cars or when passing.

Turn Signal Switch (3)

Move to  to signal a left turn,  to signal a right turn. Press to turn signal off.

Horn Button (4)

Press the button to sound the horn.

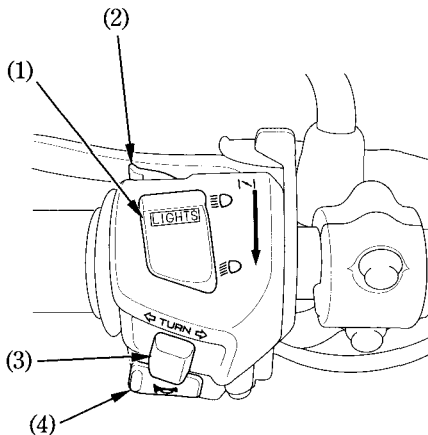

- (1) Headlight dimmer switch
- (2) Passing light control switch
- (3) Turn signal switch
- (4) Horn button

FEATURES

(Not required for operation)

STEERING LOCK

To lock the steering, turn the handlebar all the way to the left, turn the ignition key (1) to LOCK while pushing in. Remove the key. To unlock the steering, turn the key to OFF while pushing in.

Do not turn the key to LOCK while riding the motorcycle; loss of vehicle control will result.

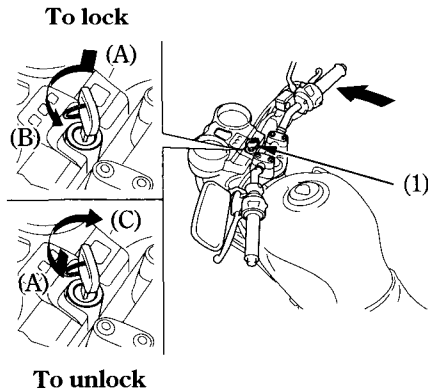

(1) Ignition key

(A) Push in

(B) Turn to LOCK

(C) Turn to OFF

HELMET HOLDER

The helmet holder (1) is on the left side below the seat.

Insert the ignition key (2) and turn it clockwise to unlock. Hang your helmet on the holder hook (3). Turn the key counterclockwise to lock the holder hook and then remove the key.

⚠ WARNING

Riding with a helmet attached to the holder can interfere with the rear wheel or suspension and could cause a crash in which you can be seriously hurt or killed.

Use the helmet holder only while parked. Do not ride with a helmet secured by the holder.

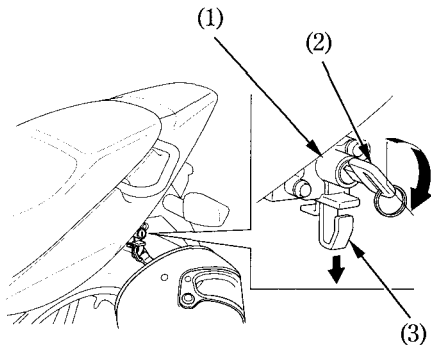

- (1) Helmet holder
- (2) Ignition key
- (3) Holder hook

SEAT

The seat must be removed for air cleaner maintenance, to remove the left side cover, or to access the tool kit and owner's manual.

Removal:

1. Insert the ignition key (1) into the seat lock (2) and turn it clockwise.
2. Pull the seat lock lever (3) downward to unlock the seat.
Pull the seat (4) back and up.

Installation:

1. Insert the front prong (5) into the front stay (6) and the rear prongs (7) into the rear stays (8) on the frame.
2. Push forward and then down on the rear of the seat.

Be sure the seat is locked securely in position after installation.

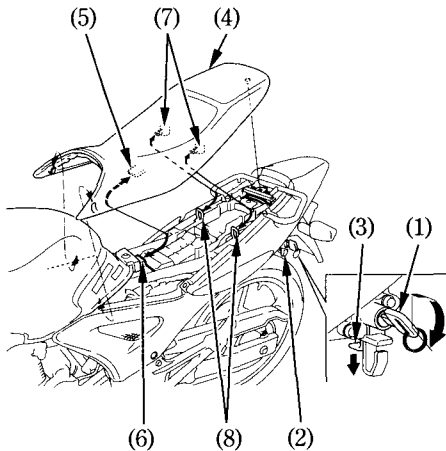

- | | |
|---------------------|-----------------|
| (1) Ignition key | (5) Front prong |
| (2) Seat lock | (6) Front stay |
| (3) Seat lock lever | (7) Rear prongs |
| (4) Seat | (8) Rear stays |

DOCUMENT BAG

The document bag (1) is in the document compartment (2) under the seat.

This owner's manual and other documents should be stored in the document bag.

When washing your motorcycle, be careful not to flood this area with water.

Do not store gloves, rain gear, or other items under the seat. They might block the air cleaner intake opening and cause starting and driveability problems.

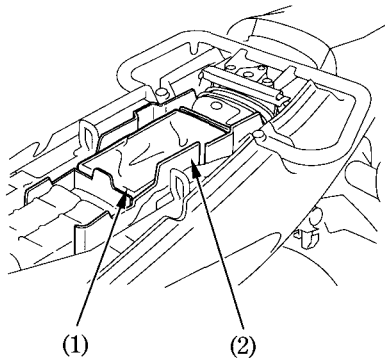

- (1) Document bag
- (2) Document compartment

LEFT SIDE COVER

The left side cover must be removed for battery and fuse maintenance.

Removal:

1. Remove the seat (page 42).
2. Remove the screw A (1) and screws B (2).
3. Pull out the prong (3) from the grommet (4).
4. Remove the side cover.

Installation:

1. Align the prong with the grommet. Press the side cover into position.
2. Fasten the screw A and screws B.

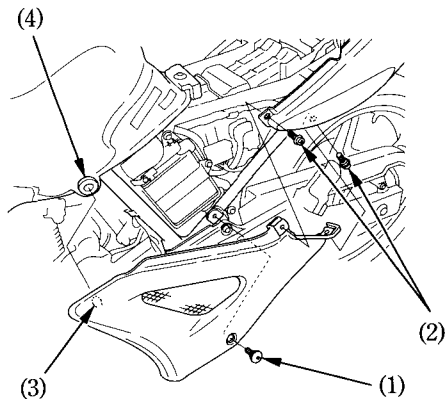

- (1) Screw A
(2) Screws B

- (3) Prong
(4) Grommet

HEADLIGHT AIM VERTICAL ADJUSTMENT

Vertical adjustment can be made by moving the headlight case (1) as necessary.

To move the headlight case, loosen the bolts (2).

Tighten the bolts after adjustment.

Obey local laws and regulations.

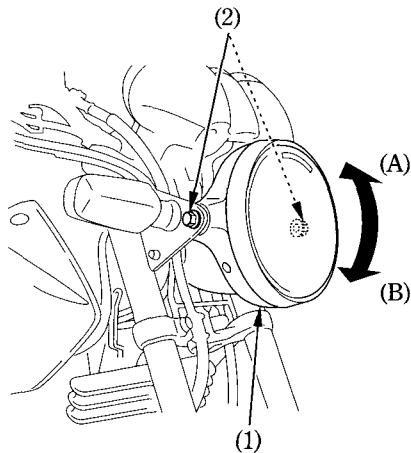

(1) Headlight case

(2) Bolts

(A) Up

(B) Down

OPERATION

PRE-RIDE INSPECTION

For your safety, it is very important to take a few moments before each ride to walk around your motorcycle and check its condition. If you detect any problem, be sure you take care of it, or have it corrected by your Honda dealer.

WARNING

Improperly maintaining this motorcycle or failing to correct a problem before riding can cause a crash in which you can be seriously hurt or killed.

Always perform a pre-ride inspection before every ride and correct any problems.

1. Engine oil level * add engine oil if required (page 29). Check for leaks.
2. Fuel level * fill fuel tank when necessary (page 26). Check for leaks.
3. Brakes * check operation;
Front: Make sure there is no brake fluid leakage (pages 19 * 20).
Rear: Adjust freeplay if necessary (pages 21 * 22).

4. Tyres *check condition and pressure (pages 30 * 35).
5. Drive chain *check condition and slack (page 78). Adjust and lubricate if necessary.
6. Throttle *check for smooth opening and full closing in all steering positions.
7. Lights and horn *check that headlight, brake/tail light, turn signals, indicators and horn function properly.
8. Engine stop switch *check for proper function (page 38).
9. Side stand ignition cut-off system *check for proper function (page 85).

STARTING THE ENGINE

Always follow the proper starting procedure described below.

This motorcycle is equipped with a side stand ignition cut-off system. The engine cannot be started if the side stand is down, unless the transmission is in neutral. If the side stand is up, the engine can be started in neutral or in gear with the clutch lever pulled in. After starting with the side stand down, the engine will shut off if the transmission is put in gear before raising the side stand.

To protect the catalytic converter in your motorcycle's exhaust system, avoid extending idling and the use of leaded petrol.

Your motorcycle's exhaust contains poisonous carbon monoxide gas. High levels of carbon monoxide can collect rapidly in enclosed areas such as a garage. Do not run the engine with the garage door closed. Even with the door open, run the engine only long enough to move your motorcycle out of the garage.

Do not use the electric starter for more than 5 seconds at a time. Release the start button for approximately 10 seconds before pressing it again.

Preparation

Before starting, insert the key, turn the ignition switch ON and confirm the following:

- The transmission is in NEUTRAL (neutral indicator light ON).
- The fuel valve is ON.
- The engine stop switch is at \odot (RUN).

Starting Procedure

To restart a warm engine, follow the procedure for “High Air Temperature.”

Normal Air Temperature

$10^{\circ} * 35^{\circ}C$ ($50^{\circ} * 95^{\circ}F$)

1. Pull the choke lever (1) back all the way to Fully ON (A), if the engine is cold.
2. With the throttle closed, press the start button.

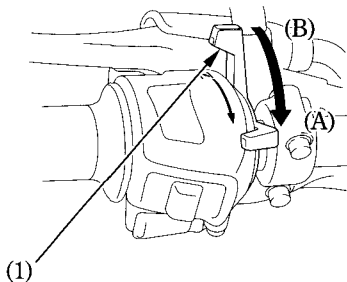

(1) Choke lever

(A) Fully ON

(B) Fully OFF

Do not open the throttle when starting the engine with the choke ON. This will lean the mixture, resulting in hard starting.

NOTICE

Operating the engine with insufficient oil pressure can cause serious engine damage.

3. Immediately after the engine starts, operate the choke lever to keep fast idle at:
2,300 * 3,400 min⁻¹ (rpm)
4. About a half minute after the engine starts, push the choke lever forward all the way to Fully OFF (B).
5. If idling is unstable, open the throttle slightly.

High Air Temperature

35°C (95°F) or above

1. Do not use the choke.
2. With the throttle slightly open, press the start button.

Low Air Temperature

10°C (50°F) or below

1. Follow steps 1 * 2 under “Normal Air Temperature.”
2. When engine speed begins to pick up, operate the choke lever to keep fast idle at:
2,300 * 3,400 min⁻¹ (rpm)
3. Continue warming up the engine until it runs smoothly and responds to the throttle, when the choke lever is at Fully OFF (B).

NOTICE

Extended use of the choke may impair piston and cylinder wall lubrication and damage the engine.

Flooded Engine

If the engine fails to start after repeated attempts, it may be flooded with excess fuel. To clear a flooded engine, leave the engine stop switch on \odot (RUN) and push the choke lever forward to Fully OFF (B). Open the throttle fully and crank the engine for 5 seconds. If the engine starts, quickly close the throttle, then open it slightly if idling is unstable. If the engine does not start, wait 10 seconds, then follow the Starting Procedure.

RUNNING-IN

Help assure your motorcycle's future reliability and performance by paying extra attention to how you ride during the first 500 km (300 miles).

During this period, avoid full-throttle starts and rapid acceleration.

RIDING

Review Motorcycle Safety (pages 1 * 7) before you ride.

Make sure you understand the function of the side stand mechanism. (See MAINTENANCE SCHEDULE on page 62 and explanation for SIDE STAND on page 85).

1. After the engine has been warmed up, the motorcycle is ready for riding.
2. While the engine is idling, pull in the clutch lever and depress the shift lever to shift into 1st (low) gear.
3. Slowly release the clutch lever and at the same time gradually increase engine speed by opening the throttle. Coordination of the throttle and clutch lever will assure a smooth positive start.

4. When the motorcycle attains a moderate speed, close the throttle, pull in the clutch lever and shift to 2nd gear by raising the shift lever.

This sequence is repeated to progressively shift to 3rd, 4th, 5th and 6th (top) gear.

5. Coordinate the throttle and brakes for smooth deceleration.
6. Both front and rear brakes should be used at the same time and should not be applied strongly enough to lock the wheel, or braking effectiveness will be reduced and control of the motorcycle be difficult.

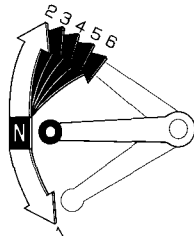

BRAKING

For normal braking, apply both the brake pedal and lever while down-shifting to match your road speed. For maximum braking, close the throttle and firmly apply the pedal and lever; pull in the clutch lever before coming to a complete stop to prevent stalling the engine.

Important Safety Reminders:

- Independent operation of only the brake lever or brake pedal reduces stopping performance.
- Extreme application of the brake controls may cause wheel lock, reducing control of the motorcycle.
- When possible, reduce speed or brake before entering a turn; closing the throttle or braking in mid-turn may cause wheel slip. Wheel slip will reduce control of the motorcycle.
- When riding in wet or rainy conditions, or on loose surfaces, the ability to maneuver and stop will be reduced. All of your actions should be smooth under these conditions. Rapid acceleration, braking or turning may cause loss of control. For your safety, exercise extreme caution when braking, accelerating or turning.
- When descending a long, steep grade, use engine compression braking by down-shifting, with intermittent use of both brakes. Continuous brake application can overheat the brakes and reduce their effectiveness.
- Riding with your foot resting on the brake pedal or your hand on the brake lever may actuate the brakelight, giving a false indication to other drivers. It may also overheat the brakes, reducing effectiveness.

PARKING

1. After stopping the motorcycle, shift the transmission into neutral, turn the handlebar fully to the left, turn the ignition switch OFF and remove the key.
2. Use the side stand to support the motorcycle while parked.

Park the motorcycle on firm, level ground to prevent it from falling over.

If you must park on a slight incline, aim the front of the motorcycle uphill to reduce the possibility of rolling off the side stand or overturning.

3. Lock the steering to help prevent theft (page 40).

Make sure flammable materials such as dry grass or leaves do not come in contact with the exhaust system when parking your motorcycle.

ANTI-THEFT TIPS

1. Always lock the steering and never leave the key in the ignition switch. This sounds simple but people do forget.
2. Be sure the registration information for your motorcycle is accurate and current.
3. Park your motorcycle in a locked garage whenever possible.
4. Use an additional anti-theft device of good quality.
5. Put your name, address, and phone number in this Owner's Manual and keep it on your motorcycles at all times.

Many times stolen motorcycles are identified by information in the Owner's Manuals that are still with them.

NAME: _____

ADDRESS: _____

PHONE NO: _____

MAINTENANCE

THE IMPORTANCE OF MAINTENANCE

A well-maintained motorcycle is essential for safe, economical and trouble-free riding. It will also help reduce air pollution.

To help you properly care for your motorcycle, the following pages include a Maintenance Schedule and a Maintenance Record for regularly scheduled maintenance.

These instructions are based on the assumption that the motorcycle will be used exclusively for its designed purpose. Sustained high speed operation or operation in unusually wet or dusty conditions will require more frequent service than specified in the Maintenance Schedule. Consult your Honda dealer for recommendations applicable to your individual needs and use.

If your motorcycle overturns or becomes involved in a crash, be sure your Honda dealer inspects all major parts, even if you are able to make some repairs.

WARNING

Improperly maintaining this motorcycle or failing to correct a problem before you ride can cause a crash in which you can be seriously hurt or killed.

Always follow the inspection and maintenance recommendations and schedules in this owner's manual.

MAINTENANCE SAFETY

This section includes instructions on some important maintenance tasks. You can perform some of these tasks with the tools provided * if you have basic mechanical skills.

Other tasks that are more difficult and require special tools are best performed by professionals. Wheel removal should normally be handled only by a Honda technician or other qualified mechanic; instructions are included in this manual only to assist in emergency service.

Some of the most important safety precautions follow. However, we cannot warn you of every conceivable hazard that can arise in performing maintenance. Only you can decide whether or not you should perform a given task.

WARNING

Failure to properly follow maintenance instructions and precautions can cause you to be seriously hurt or killed.

Always follow the procedures and precautions in this owner's manual.

SAFETY PRECAUTIONS

- Make sure the engine is off before you begin any maintenance or repairs. This will help eliminate several potential hazards:
 - * **Carbon monoxide poisoning from engine exhaust.**
Be sure there is adequate ventilation whenever you operate the engine.
 - * **Burns from hot parts.**
Let the engine and exhaust system cool before touching.
 - * **Injury from moving parts.**
Do not run the engine unless instructed to do so.
- Read the instructions before you begin, and make sure you have the tools and skills required.
- To help prevent the motorcycle from falling over, park it on a firm, level surface, using the side stand or a maintenance stand to provide support.

- To reduce the possibility of a fire or explosion, be careful when working around petrol or batteries. Use only nonflammable solvent, not petrol, to clean parts. Keep cigarettes, sparks and flames away from the battery and all fuel-related parts.

Remember that your Honda dealer knows your motorcycle best and is fully equipped to maintain and repair it.

To ensure the best quality and reliability, use only new genuine Honda parts or their equivalents for repair and replacement.

MAINTENANCE SCHEDULE

Perform the Pre-ride Inspection (page 46) at each scheduled maintenance period.

I: INSPECT AND CLEAN, ADJUST, LUBRICATE OR REPLACE IF NECESSARY

C: CLEAN R: REPLACE A: ADJUST L: LUBRICATE

The following items require some mechanical knowledge. Certain items (particularly those marked and) may require more technical information and tools. Consult your Honda dealer.

- * Should be serviced by your Honda dealer, unless the owner has proper tools and service data and is mechanically qualified. Refer to the Official Honda Shop Manual.
- ** In the interest of safety, we recommend these items be serviced only by your Honda dealer.

Honda recommends that your Honda dealer should road test your motorcycle after each periodic maintenance is carried out.

- NOTES:
- (1) At higher odometer readings, repeat at the frequency interval established here.
 - (2) Service more frequently when riding in unusually wet or dusty areas.
 - (3) Service more frequently when riding in rain or at full throttle.
 - (4) Replace every 2 years, or at indicated odometer interval, whichever comes first. Replacement requires mechanical skill.

ITEM	FREQUENCY	WHICHEVER → COMES FIRST ↓ NOTE	ODOMETER READING [NOTE (1)]								Refer to Page
			× 1,000 km	1	6	12	18	24	30	36	
			× 1,000 mi	0.6	4	8	12	16	20	24	
* FUEL LINE					I		I		I	*	
* FUEL STRAINER SCREEN				C	C	C	C	C	C	*	
* THROTTLE OPERATION					I		I		I	76	
* CHOKE OPERATION					I		I		I	*	
AIR CLEANER	NOTE (2)			C	C	R	C	C	R	66	
CRANKCASE BREATHER	NOTE (3)			C	C	C	C	C	C	67	
SPARK PLUG					R		R		R	74	
* VALVE CLEARANCE					I		I		I	*	
ENGINE OIL			R		R		R		R	68	
ENGINE OIL FILTER			R		R		R		R	71	
* ENGINE IDLE SPEED			I	I	I	I	I	I	I	77	
* SECONDARY AIR SUPPLY SYSTEM					I		I		I	*	

ITEM	FREQUENCY	WHICHEVER → COMES FIRST ↓ NOTE	ODOMETER READING [NOTE (1)]								Refer to Page
			× 1,000 km	1	6	12	18	24	30	36	
			× 1,000 mi	0.6	4	8	12	16	20	24	
		MONTH		6	12	18	24	30	36		
	DRIVE CHAIN		EVERY 1,000 km (600 mi) I, L								78
	BRAKE FLUID	NOTE (4)		I	I	R	I	I	R	20	
	BRAKE SHOES/PADS WEAR			I	I	I	I	I	I	91, 92	
	BRAKE SYSTEM		I		I		I		I	19, 91, 92	
*	BRAKELIGHT SWITCH				I		I		I	98	
*	HEADLIGHT AIM				I		I		I	45	
	CLUTCH SYSTEM		I	I	I	I	I	I	I	23	
	SIDE STAND				I		I		I	85	
*	SUSPENSION				I		I		I	84	
*	NUTS, BOLTS, FASTENERS		I		I		I		I	*	
**	WHEELS/TYRES				I		I		I	*	
**	STEERING HEAD BEARINGS		I		I		I		I	*	

TOOL KIT

The tool kit (1) is under the seat (page 42). Some roadside repairs, minor adjustments and parts replacement can be performed with the tools contained in the kit.

- 10 × 12 mm Open end wrench
- 14 × 17 mm Open end wrench
- No. 2 screwdriver
- No. 2 Phillips screwdriver
- 24 mm Box end wrench
- Extension bar
- Spark plug wrench
- Tool bag

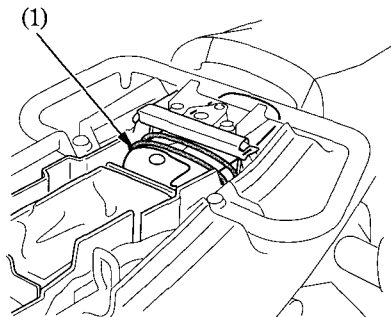

(1) Tool kit

SERIAL NUMBERS

The frame and engine serial numbers are required when registering your motorcycle. They may also be required by your dealer when ordering replacement parts. Record the numbers here for your reference.

FRAME NO. _____

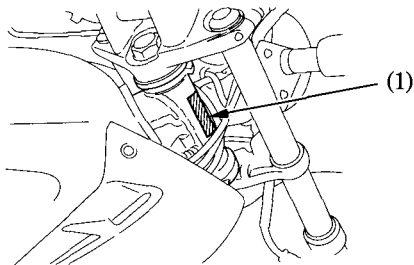

(1) Frame number

The frame number (1) is stamped on the right side of the steering head.

The engine number (2) is stamped on the left side of the crankcase.

ENGINE NO. _____

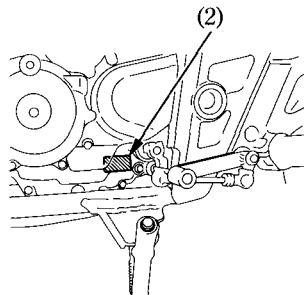

(2) Engine number

COLOUR LABEL

The colour label (1) is attached to the right side of the frame.

It is helpful when ordering replacement parts. Record the colour and code here for your reference.

COLOUR _____

CODE _____

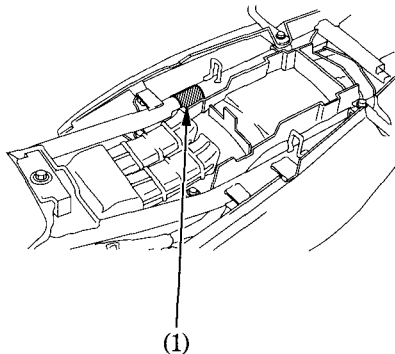

(1) Colour label

AIR CLEANER

Refer to the Safety Precautions on page 59 .

The air cleaner should be serviced at regular intervals (page 61). Service more frequently when riding in unusually wet or dusty areas.

1. Remove the seat (page 42).
2. Remove the air cleaner housing cover (1) by removing the screws (2).
3. Pull out and clean the air cleaner element (3) using compressed air from the outside, or replace if it necessary.
4. Install the air cleaner element.
5. Install the air cleaner housing cover and screws.
6. Install the seat.

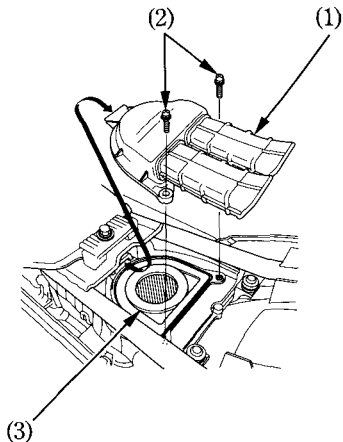

- (1) Air cleaner housing cover
(2) Screws
(3) Air cleaner element

CRANKCASE BREATHER

Refer to the Safety Precautions on page 59 .

1. Remove the crankcase breather tube plug (1).
2. Drain deposits into a suitable container.
3. Reinstall the crankcase breather tube plug.

Service more frequently if your motorcycle is ridden in the rain or often at full throttle. Service the breather if you can see deposits in the transparent section of the drain tube.

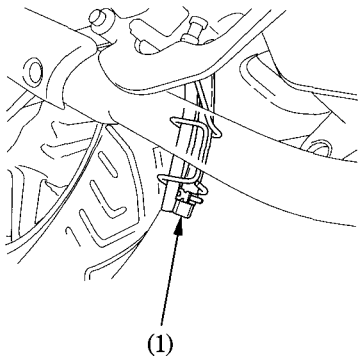

(1) Crankcase breather tube plug

ENGINE OIL

Refer to the Safety Precautions on page 59 .

Oil Recommendation

API classification	SG or higher except oils labeled as energy conserving on the circular API service label
Viscosity	SAE 10W-30
JASO T 903 standard	MA

Suggested Oil
Honda "4-STROKE MOTORCYCLE OIL" or equivalent.

Your motorcycle does not need oil additives. Use the recommended oil.

Do not use oils with graphite or molybdenum additives. They may adversely affect clutch operation.

Do not use API SH or higher oils displaying a circular API "energy conserving" service label on the container. They may affect lubrication and clutch performance.

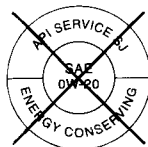

NOT RECOMMENDED

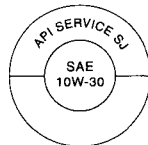

OK

Do not use non-detergent, vegetable, or castor based racing oils.

Viscosity:

Viscosity grade of engine oil should be based on average atmospheric temperature in your riding area. The following provides a guide to the selection of the proper grade or viscosity of oil to be used at various atmospheric temperatures.

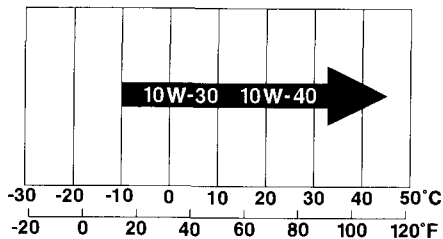

JASO T 903 standard

The JASO T 903 standard is an index for engine oils for 4-stroke motorcycle engines.

There are two classes: MA and MB.

Oil conforming to the standard is labeled on the oil container. For example, the following label shows the MA classification.

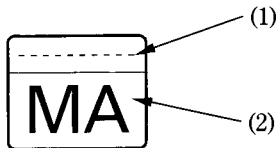

PRODUCT MEETING JASO T 903
COMPANY GUARANTEEING THIS MA PERFORMANCE:

- (1) Code number of the sales company of the oil
- (2) Oil classification

Engine Oil and Filter

Engine oil quality is the chief factor affecting engine service life. Change the engine oil as specified in the maintenance schedule (page 61).

When running in very dusty conditions, oil changes should be performed more frequently than specified in the maintenance schedule.

Please dispose of used engine oil in a manner that is compatible with the environment. We suggest you take it in a sealed container to your local recycling center or service station for reclamation. Do not throw it in the trash or pour it on the ground or down a drain.

Used engine oil may cause skin cancer if repeatedly left in contact with the skin for prolonged periods. Although this is unlikely unless you handle used oil on a daily basis, it is still advisable to thoroughly wash your hands with soap and water as soon as possible after handling used oil.

Changing the oil filter requires a special oil filter tool and a torque wrench. If you do not have these tools and the necessary skill, we recommend that you have your Honda dealer perform this service.

If a torque wrench is not used for this installation, see your Honda dealer as soon as possible to verify proper assembly.

Change the engine oil with the engine at normal operating temperature and the motorcycle on its side stand to assure complete and rapid draining.

1. To drain the oil, remove the oil filler cap/dipstick, oil drain plug (1) and sealing washer (2).
2. After the engine oil has been drained out, hold the motorcycle upright for 10*15 seconds to assure complete draining.

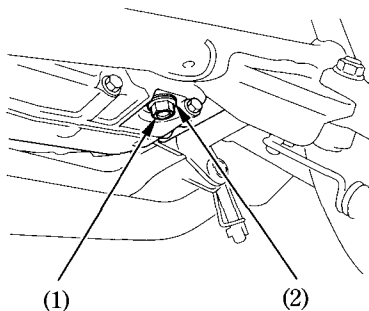

- (1) Oil drain plug
 (2) Sealing washer

3. Remove the oil filter bolts (3) and oil filter cover (4).
4. Remove the oil filter (5) from the cover.
5. Check that the oil filter cover O-ring (6) is in good condition and then install the spring (7) and new oil filter. Use the Honda oil filter or an equivalent filter specified for your model. Other filters not specified for your model may not filter impurities properly.

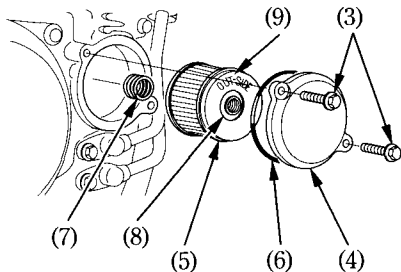

- (3) Oil filter bolts
 (4) Oil filter cover
 (5) Oil filter
 (6) O-ring
 (7) Spring
 (8) Rubber seal
 (9) "OUT-SIDE" mark

6. Install the oil filter with the rubber seal (8) facing out, away from the engine. You will see "OUT-SIDE" mark (9) on the filter body, near the seal.

NOTICE

Improper installation of the oil filter can cause serious engine damage.

7. Reinstall the oil filter cover, making sure the bolts are tightened securely.
Oil filter bolt torque:
12 N·m (1.2 kgf·m , 9 lbf·ft)
8. Check that the sealing washer on the drain plug is in good condition and install the plug. Replace the sealing washer every other time the oil is changed, or each time if necessary.
Oil drain plug torque:
30 N·m (3.1 kgf·m , 22 lbf·ft)
9. Fill the crankcase with the recommended grade oil; approximately:
1.5 ℓ (1.6 US qt , 1.3 Imp qt)
10. Install the oil filler cap/dipstick.
11. Start the engine and let it idle for 3*5 minutes.
12. 2*3 minutes after stopping the engine, check that the oil level is at the upper level mark on the oil filler cap/dipstick with the motorcycle upright on firm, level ground. Make sure there are no oil leaks.

SPARK PLUG

Refer to the Safety Precautions on page 59 .

Recommended plugs:

CR8EH * 9S (NGK)

For extended high speed riding:

CR9EH * 9S (NGK)

NOTICE

Never use a spark plug with an improper heat range. Severe engine damage could result.

1. Disconnect the spark plug cap (1) from the spark plug.
2. Clean any dirt from around the spark plug base.
Remove the spark plug using the spark plug wrench (2) furnished in the tool kit.

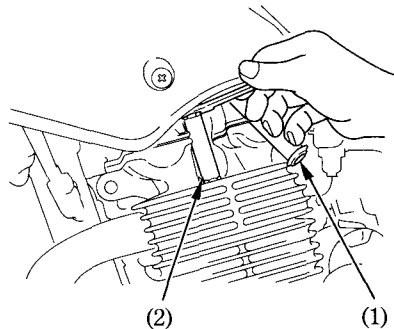

(1) Spark plug cap

(2) Spark plug wrench

3. Discard the spark plug.
4. With the plug washer attached, thread the spark plug in by hand to prevent cross-threading.
5. Tighten the spark plug:
 - If the old plug is good:
 - 1/8 turn after it seats.
 - If installing a new plug, tighten it twice to prevent loosening:
 - a) First, tighten the plug:
NGK: 3/4 turn after it seats.
 - b) Then loosen the plug.
 - c) Next, tighten the plug again:
1/8 turn after it seats.

NOTICE

Improperly tightened spark plug can damage the engine. If a plug is too loose, a piston may be damaged. If a plug is too tight, the threads may be damaged.

6. Reinstall the spark plug cap.

THROTTLE OPERATION

Refer to the Safety Precautions on page 59 .

1. Check for smooth rotation of the throttle grip from the fully open to the fully closed position at both full steering positions.
2. Measure the throttle grip freeplay at the throttle grip flange.
The standard freeplay should be approximately:
2 * 6 mm (0.1 * 0.2 in)

To adjust the freeplay, loosen the lock nut (1) and turn the adjuster (2).

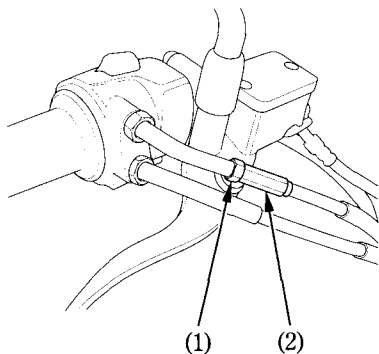

- (1) Lock nut
(2) Adjuster

IDLE SPEED

Refer to the Safety Precautions on page 59 .

The engine must be at normal operating temperature for accurate idle speed adjustment. 10 minutes of stop-and-go riding is sufficient.

Do not attempt to compensate for faults in other systems by adjusting idle speed. See your Honda dealer for regularly scheduled carburetor adjustments.

1. Warm up the engine, and shift to neutral, and place the motorcycle on its side stand.
2. Adjust idle speed with the throttle stop screw (1).

Idle speed (In neutral):

$1,400 \pm 100 \text{ min}^{-1} (\text{rpm})$

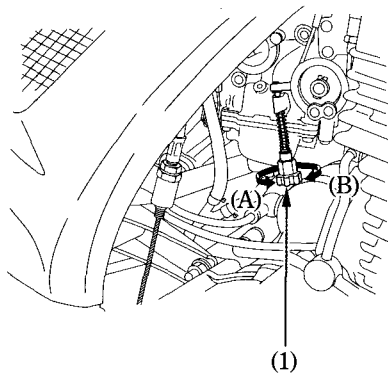

(1) Throttle stop screw

(A) Increase

(B) Decrease

DRIVE CHAIN

Refer to the Safety Precautions on page 59 .

The service life of the drive chain is dependent upon proper lubrication and adjustment. Poor maintenance can cause premature wear or damage to the drive chain and sprockets.

The drive chain should be checked and lubricated as part of the Pre-ride Inspection (page 47). Under severe usage, or when the motorcycle is ridden in unusually dusty or muddy areas, more frequent maintenance will be necessary.

Inspection:

1. Turn the engine off, place the motorcycle on its side stand, and shift the transmission into neutral.
2. Check slack in the lower drive chain run midway between the sprockets.

Drive chain slack should be adjusted to allow the following vertical movement by hand:

15 * 25 mm (0.6 * 1.0 in)

3. Roll the motorcycle forward. Stop. Check the drive chain slack. Repeat this procedure several times. Drive chain slack should remain constant. If the chain is slack only in certain sections, some links are kinked and binding. Binding and kinking can frequently be eliminated by lubrication.

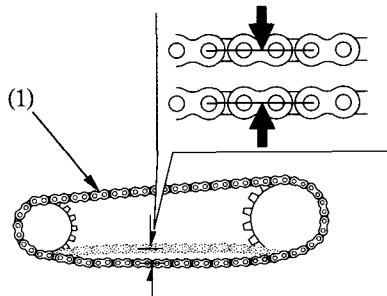

(1) Drive chain

4. Roll the motorcycle forward. Stop and place it on its side stand. Inspect the drive chain and sprockets for any of the following conditions:

DRIVE CHAIN

- *Damaged Rollers
- *Loose Pins
- *Dry or Rusted Links
- *Kinked or Binding Links
- *Excessive Wear
- *Improper Adjustment
- *Damaged or Missing O-rings

SPROCKETS

- *Excessively Worn Teeth
- *Broken or Damaged Teeth

A drive chain with damaged rollers, loose pins, or missing O-rings must be replaced. A chain which appears dry, or shows signs of rust, requires supplementary lubrication. Kinked or binding links should be thoroughly lubricated and worked free. If links cannot be freed, the chain must be replaced.

Damaged sprocket
Teeth

Worn sprocket
Teeth

Replace

Replace

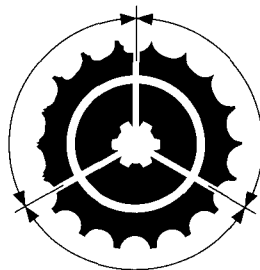

Normal sprocket Teeth

GOOD

Adjustment:

Drive chain slack should be checked and adjusted, if necessary, every 1,000 km (600 miles). When operated at sustained high speeds or under conditions of frequent rapid acceleration, the chain may require more frequent adjustment.

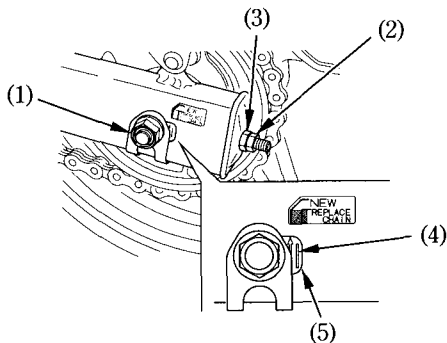

- (1) Rear axle nut
- (2) Drive chain lock nut
- (3) Drive chain adjusting nut

- (4) Index mark
- (5) Rear edge of adjusting slot

If the drive chain requires adjustment, the procedure is as follows:

1. Place the motorcycle on its side stand with the transmission in neutral and the ignition switch off.
2. Loosen the rear axle nut (1).
3. Loosen the drive chain lock nuts (2) on both sides of the swingarm.
4. Turn both drive chain adjusting nuts (3) an equal number of turns until the correct drive chain slack is obtained. Turn the drive chain adjusting nuts clockwise to tighten the chain, or counterclockwise to provide more slack. Adjust the chain slack at a point midway between the drive sprocket and the rear wheel sprocket. Roll the motorcycle forward. Stop and place it on its side stand. Recheck chain slack.

Chain slack should be:

15 * 25 mm (0.6 * 1.0 in)

5. Check rear axle alignment by making sure the chain adjuster index marks (4) align with the rear edge (5) of the adjusting slots.

Both marks should correspond. If the axle is misaligned, turn the right or left drive chain adjusting nut until the marks correspond on the rear edge of the adjusting slots and recheck chain slack.

6. Tighten the rear axle nut to specified torque.

Rear axle nut torque:

88 N·m (9.0 kgf·m , 65 lbf·ft)

If a torque wrench is not used for this installation, see your Honda dealer as soon as possible to verify proper assembly.

7. Tighten the drive chain adjusting nuts lightly, then tighten the drive chain lock nuts by holding the drive chain adjusting nuts with a spanner.

8. Recheck drive chain slack.

9. Rear brake pedal freeplay is affected when repositioning the rear wheel to adjust drive chain slack. Check rear brake pedal freeplay and adjust as necessary (page 21).

Wear Inspection:

Check the chain wear label when adjusting the chain. If the red zone (6) on the label aligns with the rear edge of the axle washer (7) after the chain has been adjusted to the proper slack, the chain is excessively worn and must be replaced. The proper slack is:

15 * 25 mm (0.6 * 1.0 in)

Damage to the bottom part of the frame may be caused by excessive drive chain slack of more than:

50 mm (2.0 in)

Replacement Chain:

D.I.D.520

This motorcycle has a staked master link drive chain which requires a special tool for cutting and staking. Do not use an ordinary master link with this chain. See your Honda dealer.

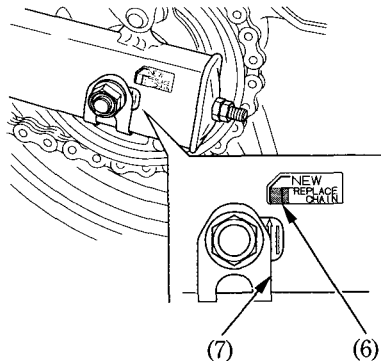

(6) Red zone

(7) Rear edge of axle washer

Lubrication and Cleaning:

Lubricate every 1,000 km (600 miles) or sooner if chain appears dry.

The drive chain on this motorcycle is equipped with small O-rings between the link plates. These O-rings retain grease inside the chain to improve its service life.

The O-rings in this chain can be damaged by steam cleaning, high pressure washers, and certain solvents. Clean the side surfaces of the chain with a dry cloth. Do not brush the rubber O-rings. Brushing will damage them. Wipe dry and lubricate only with SAE 80 or 90 gear oil. Commercial chain lubricants may contain solvents which could damage the rubber O-rings.

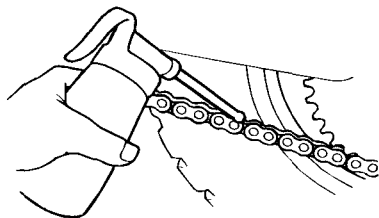

FRONT AND REAR SUSPENSION INSPECTION

Refer to the Safety Precautions on page 59 .

1. Check the fork assembly by locking the front brake and pumping the fork up and down vigorously. Suspension action should be smooth and there must be no oil leakage.
2. Swingarm bearings should be checked by pushing hard against the side of the rear wheel while the motorcycle is on a support block. Freeplay indicates worn bearings.
3. Carefully inspect all front and rear suspension fasteners for tightness.

SIDE STAND

Refer to the Safety Precautions on page 59 .

Perform the following maintenance in accordance with the maintenance schedule.

Functional Check:

- Check the side stand spring (1) for damage or loss of tension and the side stand assembly for freedom of movement.
- Check the side stand ignition cut-off system:
 1. Sit astride the motorcycle; put the side stand up and the transmission in neutral.
 2. Start the engine and with the clutch lever pulled in, shift the transmission into gear.
 3. Lower the side stand. The engine should stop as you put the side stand down.

If the side stand system does not operate as described, see your Honda dealer for service.

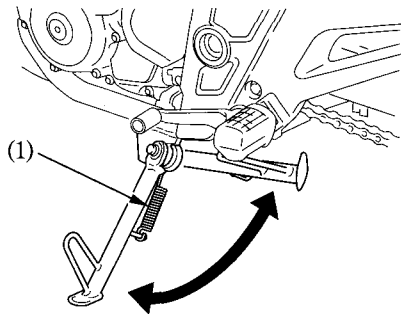

(1) Side stand spring

WHEEL REMOVAL

Refer to the Safety Precautions on page 59 .

This motorcycle is equipped with a side stand only. Therefore, if front or rear wheel removal is required, it will be necessary to raise the center of the motorcycle with a jack or other firm support. If none is available, see your Honda dealer for this service.

Front Wheel Removal

1. Raise the front wheel off the ground by placing a support block under the engine.
2. Disconnect the speedometer cable (1) by removing the speedometer cable set screw (2).

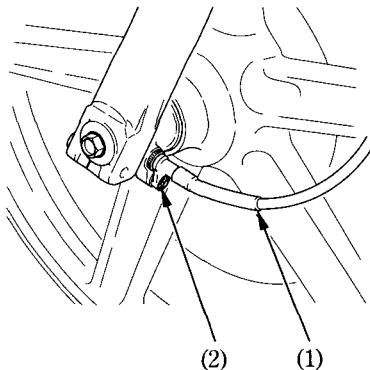

- (1) Speedometer cable
(2) Speedometer cable set screw

3. Loosen the axle pinch bolt (3).
4. Remove the front axle nut (4).
5. Remove the front axle shaft (5), front wheel and side collar.

Do not depress the brake lever when the wheel is off the motorcycle. The caliper pistons will be forced out of the cylinders with subsequent loss of brake fluid. If this occurs, servicing of the brake system will be necessary. See your Honda dealer for this service.

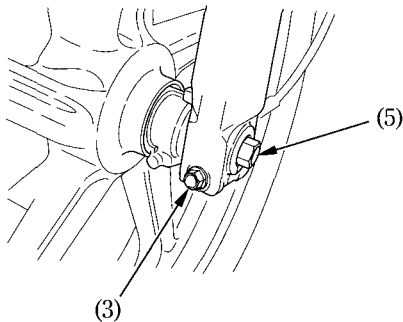

- (3) Axle pinch bolt
- (5) Front axle shaft

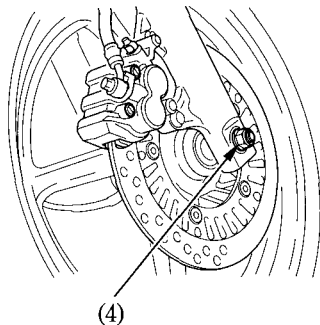

- (4) Front axle nut

Installation:

Install the side collar into the right side wheel hub.

1. Position the wheel between the fork legs and insert the front axle shaft from the left side, through the left fork leg and wheel hub.

To avoid damaging the brake pads while installing the wheel, carefully fit the brake disc between the pads.

2. Make sure that the lug (6) on the left fork leg is contacting the lug (7) on the speedometer gear box.
3. Tighten the front axle nut to the specified torque.

Front axle nut torque:

59 N·m (6.0 kgf·m , 44 lbf·ft)

4. Tighten the axle pinch bolt on the left fork leg to the specified torque.

Axle pinch bolt torque:

22 N·m (2.2 kgf·m , 16 lbf·ft)

If a torque wrench was not used for installation, see your Honda dealer as soon as possible to verify proper assembly. Improper assembly may lead to loss of braking capacity.

5. Install the speedometer cable and tighten the screw securely.

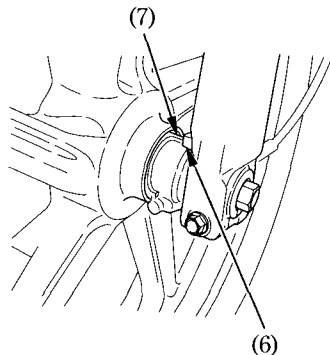

(6) Lug

(7) Lug

Rear Wheel Removal

Refer to the Safety Precautions on page 59 .

1. Raise the rear wheel off the ground by placing a support block under the engine.
2. Remove the rear brake adjusting nut (1), disconnect the brake rod (2) from the brake arm (3) by pushing down on the rear brake pedal.

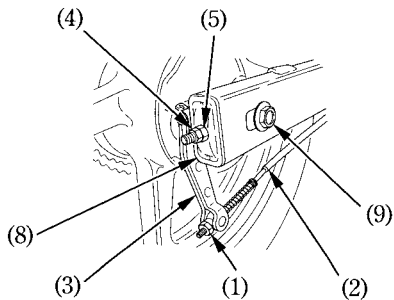

- | | |
|------------------------------|--------------------------------|
| (1) Rear brake adjusting nut | (4) Drive chain lock nuts |
| (2) Brake rod | (5) Drive chain adjusting nuts |
| (3) Brake arm | (9) Rear axle shaft |

3. Loosen the drive chain lock nuts (4) and drive chain adjusting nuts (5).
4. Remove the rear axle nut (6), axle washer (7) and chain adjusters (8), and pull out the rear axle shaft (9).
Push the wheel forward and remove the drive chain from the rear sprocket.
5. Remove the rear wheel and side collar.

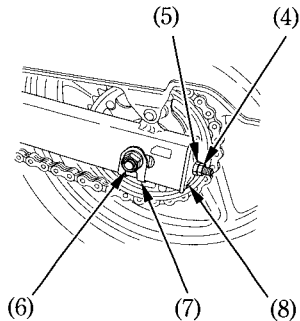

- | | |
|-------------------|---------------------|
| (6) Rear axle nut | (8) Chain adjusters |
| (7) Axle washer | |

Installation Notes:

- To install the rear wheel, reverse the removal procedure.
- Install the side collar into the left side wheel hub.
- Make sure that the lug (10) on the swingarm (11) is located in the slot (12) in the brake panel (13).
- Tighten the rear axle nut to the specified torque.

Rear axle nut torque:

88 N·m (9.0 kgf·m , 65 lbf·ft)

- Adjust the drive chain (page 80) and rear brake pedal freeplay (page 21).
- After installing the wheel, apply the brake several times and then check if the wheel rotates freely. Recheck the wheel if the brake drags or if the wheel does not rotate freely.

If a torque wrench was not used for installation, see your Honda dealer as soon as possible to verify proper assembly. Improper assembly may lead to loss of braking capacity.

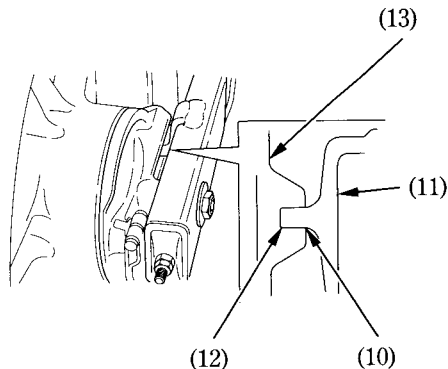

(10) Lug
(11) Swingarm

(12) Slot
(13) Brake panel

BRAKE PAD WEAR

Refer to the Safety Precautions on page 59 .

Brake pad wear depends upon the severity of usage, the type of riding, and road conditions. (Generally, the pads will wear faster on wet and dirty roads.)

Inspect the pads at each regular maintenance interval (page 62).

Front Brake

Check the wear indicator marks (1) on each pad.

If either pad is worn to the wear indicator mark, replace both pads as a set. See your Honda dealer for this service.

< FRONT BRAKE >

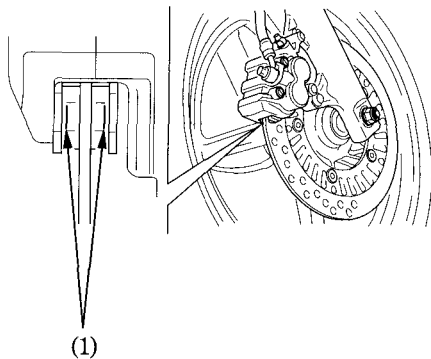

(1) Wear indicator marks

BRAKE SHOE WEAR

Refer to the Safety Precautions on page 59 .

The rear brake is equipped with a brake wear indicator.

When the brake is applied, an arrow (1) attached to the brake arm (2) moves toward a reference mark (3) on the brake panel (4). If the arrow aligns with the reference mark on full application of the brake, the brake shoes must be replaced. See your Honda dealer for this service.

When the brake service is necessary, see your Honda dealer. Use only genuine Honda parts or its equivalent.

< REAR BRAKE >

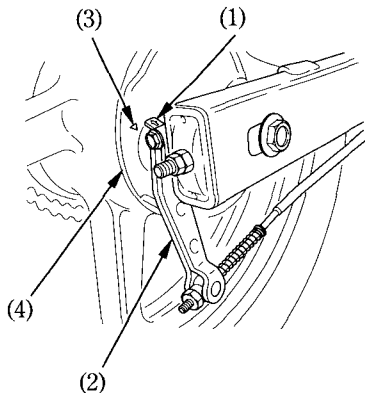

(1) Arrow
(2) Brake arm

(3) Reference mark
(4) Brake panel

BATTERY

Refer to the Safety Precautions on page 59 .

It is not necessary to check the battery electrolyte level or add distilled water as the battery is a maintenance-free (sealed) type. If your battery seems weak and/or is leaking electrolyte (causing hard starting or other electrical troubles), contact your Honda dealer.

NOTICE

Your battery is a maintenance-free type and can be permanently damaged if the cap strip is removed.

⚠ WARNING

The battery gives off explosive hydrogen gas during normal operation.

A spark or flame can cause the battery to explode with enough force to kill or seriously hurt you.

Wear protective clothing and a face shield, or have a skilled mechanic do the battery maintenance.

Removal:

1. Make sure the ignition switch is OFF.
2. Remove the seat (page 42).
3. Remove the left side cover (page 44).
4. Remove the bolt (1) and battery holder (2).
5. Disconnect the negative (*) terminal lead (3) from the battery first, then disconnect the positive (+) terminal lead (4).
6. Pull out the battery (5) from the battery box.

Installation:

1. Reinstall in the reverse order of removal. Be sure to connect the positive (+) terminal first, then the negative (*) terminal.
2. Check all bolts and other fasteners are secure.

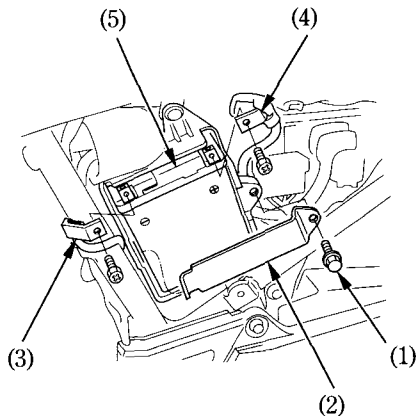

- (1) Bolt
- (2) Battery holder
- (3) Negative (*) terminal lead
- (4) Positive (+) terminal lead
- (5) Battery

FUSE REPLACEMENT

Refer to the Safety Precautions on page 59 .

When frequent fuse failure occurs, it usually indicates a short circuit or an overload in the electrical system. See your Honda dealer for repair.

NOTICE

Never use a fuse with a different rating from that specified. Serious damage to the electrical system or a fire may result, causing a dangerous loss of lights or engine power.

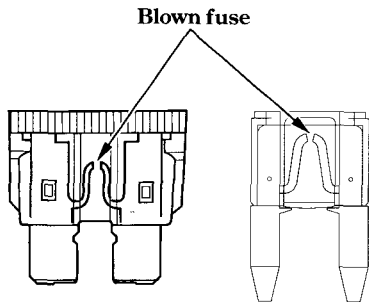

Fuse Box:

The fuse box (1) is located behind the left side cover.

The specified fuses are:

5A, 10A

1. Remove the seat (page 42).
2. Remove the left side cover (page 44).
3. Open the fuse box cover (2).
4. Pull out the fuse. If the fuse is blown, install a new fuse.

The spare fuses (3) are located in the fuse box.

5. Close the fuse box cover and install the left side cover.
6. Install the seat.

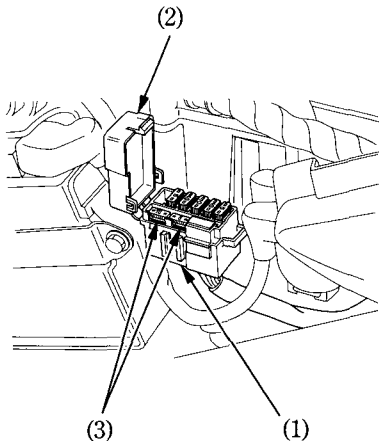

- (1) Fuse box
- (2) Fuse box cover
- (3) Spare fuses

Main Fuse:

The main fuse (1) is located behind the left side cover.

The specified fuse is:

30 A

1. Remove the seat (page 42).
2. Remove the left side cover (page 44).
3. Disconnect the wire connector (2) of the starter magnetic switch (3).
4. Pull out the old fuse and install a spare main fuse (4).

The spare main fuse is located under the starter magnetic switch.

5. Reconnect the connector and install the left side cover.
6. Install the seat.

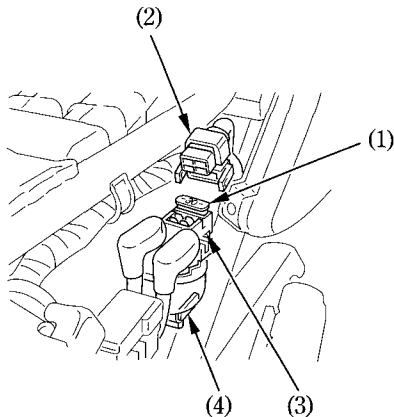

- (1) Main fuse
- (2) Wire connector
- (3) Starter magnetic switch
- (4) Spare main fuse

BRAKELIGHT SWITCH ADJUSTMENT

Refer to the Safety Precautions on page 59 .

Check the operation of the brakelight switch (1) at the right side behind the engine from time to time.

Adjustment is done by turning the adjusting nut (2). Turn the nut in the direction (A) if the switch operates too late and in direction (B) if the switch operates too soon.

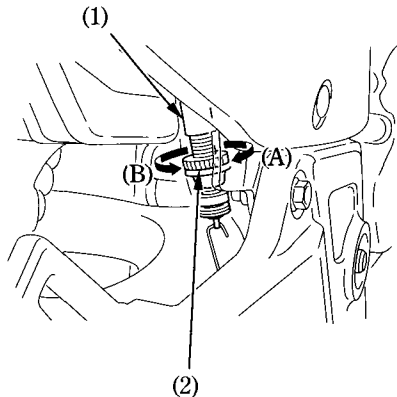

- (1) Brakelight switch
- (2) Adjusting nut

BULB REPLACEMENT

Refer to the Safety Precautions on page 59 .

The light bulb becomes very hot while the light is ON, and remains hot for a while after it is turned OFF. Be sure to let it cool down before servicing.

Do not put finger prints on the headlight bulb, as they may create hot spots on the bulb and cause it to break.

Wear clean gloves while replacing the bulb. If you touch the bulb with your bare hands, clean it with a cloth moistened with alcohol to prevent its early failure.

- Be sure to turn the ignition switch OFF when replacing the bulb.
- Do not use bulbs other than those specified.
- After installing a new bulb, check that the light operates properly.

Headlight Bulb

1. Remove the screws (1) from the headlight case.
2. Gently pull the lower end of the headlight (2) forward and remove the headlight.
3. Disconnect the connector (3).
4. Remove the seat rubber (4).
5. Remove the headlight bulb (5) while pressing down on the pin (6).

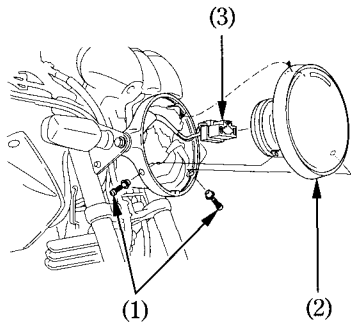

- (1) Screws
(2) Headlight

(3) Connector

6. Install a new bulb in the reverse order of removal.
 - Install the seat rubber with its "TOP" mark (7) facing up.

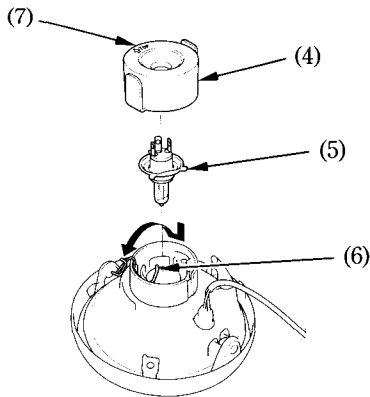

- (4) Seat rubber
(5) Headlight bulb

(6) Pin
(7) "TOP" mark

Position Light Bulb

1. Remove the headlight (1) (page 100).
2. Pull out the socket (2).
3. Pull out the bulb (3) without turning.
4. Install a new bulb in the reverse order of removal.

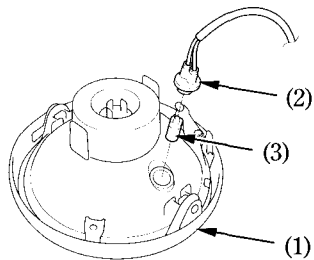

- (1) Headlight
(2) Socket
(3) Position light bulb

Brake/Tail Light Bulb

1. Remove the taillight lens (1) by removing the screws (2).

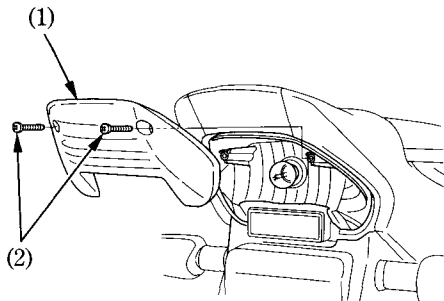

- (1) Taillight lens
- (2) Screws

2. Slightly press the bulb (3) and turn it counterclockwise.

3. Install a new bulb in the reverse order of removal.

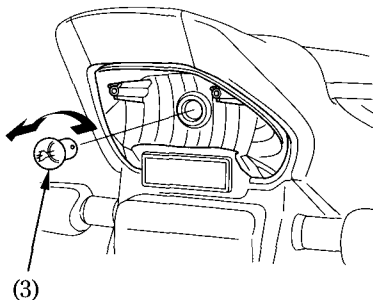

- (3) Bulb

Front/Rear Turn Signal Bulb

1. Remove the turn signal lens (1) by removing the screw (2).

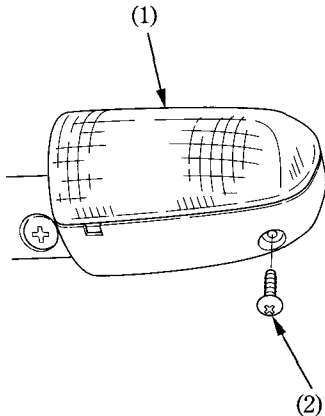

(1) Turn signal lens

(2) Screw

2. Turn the socket (3) counterclockwise, then pull it out.
3. Pull out the bulb (4) without turning.
4. Install a new bulb in the reverse order of removal.

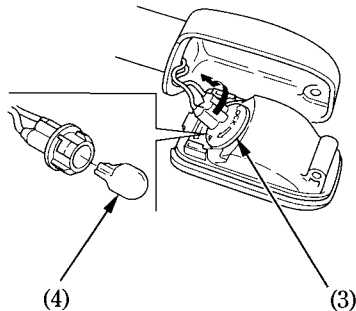

(3) Socket

(4) Bulb

License Light Bulb

1. Remove the license light lens (1) by removing the screws (2).
2. Pull out the bulb (3) without turning.
3. Install a new bulb in the reverse order of removal.

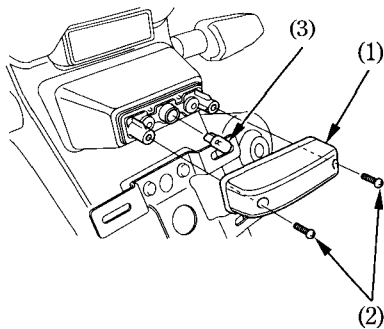

- (1) License light lens
- (2) Screws
- (3) Bulb

CLEANING

Clean your motorcycle regularly to protect the surface finishes and inspect for damage, wear, and oil or brake fluid leakage.

Avoid cleaning products that are not specifically designed for motorcycle or automobile surfaces.

They may contain harsh detergents or chemical solvents that could damage the metal, paint, and plastic on your motorcycle.

If your motorcycle is still warm from recent operation, give the engine and exhaust system time to cool off.

We recommend avoiding the use of high pressure water spray (typical in coin-operated car washes).

NOTICE

High pressure water (or air) can damage certain parts of the motorcycle.

Washing the motorcycle

1. Rinse the motorcycle thoroughly with cool water to remove loose dirt.
2. Clean the motorcycle with a sponge or soft cloth using cool water.
Avoid directing water to muffler outlet and electrical parts.
3. Clean the plastic parts using a cloth or sponge dampened with a solution of mild detergent and water. Rub the soiled area gently rinsing it frequently with fresh water.
Take care to keep brake fluid or chemical solvents off the motorcycle.
They will damage the plastic and painted surfaces.

The inside of the headlight lens may be clouded immediately after washing the motorcycle. Moisture condensation inside the headlight lens will disappear gradually by lighting the headlight in high beam. Run the engine while keeping the headlight on.

4. After cleaning, rinse the motorcycle thoroughly with plenty of clean water. Strong detergent residue can corrode alloy parts.
5. Dry the motorcycle, start the engine, and let it run for several minutes.
6. Test the brakes before riding the motorcycle. Several applications may be necessary to restore normal braking performance.
7. Lubricate the drive chain immediately after washing and drying the motorcycle.

Braking efficiency may be temporarily impaired immediately after washing the motorcycle.

Anticipate longer stopping distance to avoid a possible accident.

Finishing Touches

After washing your motorcycle, consider using a commercially-available spray cleaner/polish or quality liquid or paste wax to finish the job. Use only a non-abrasive polish or wax made specifically for motorcycles or automobiles. Apply the polish or wax according to the instructions on the container.

Removing Road Salt

The salt contained in the road surface freezing prevention medicine which a road was sprayed with in winter, and the seawater becomes the cause which rust occurs in.

Wash your motorcycle by the following point after it runs through such a place.

1. Clean the motorcycle using cool water (page 105).

Do not use warm water.

This worsens the effect of the salt.

2. Dry the motorcycle and the surface of the metal is protected with the wax.

Painted Aluminum Wheel Maintenance

Aluminum may corrode from contact with dirt, mud, or road salt. Clean the wheels after riding through any of these substances. Use a wet sponge and mild detergent. Avoid stiff brushes, steel wool, or cleaners containing abrasives or chemical compounds.

After washing, rinse with plenty of water and dry with a clean cloth.

Clean the mat colour painted surface

Using plenty of water, clean the mat colour painted surface with a soft cloth or sponge. Dry with a soft, clean cloth.

Use neutral detergent to clean mat colour painted surface.

Do not use waxes containing compounds.

STORAGE GUIDE

Extended storage, such as for winter, requires that you take certain steps to reduce the effects of deterioration from non-use of the motorcycle. In addition, necessary repairs should be made **BEFORE** storing the motorcycle; otherwise, these repairs may be forgotten by the time the motorcycle is removed from storage.

STORAGE

1. Change the engine oil and filter.
2. Empty the fuel tank into an approved petrol container using a commercially available hand siphon or an equivalent method. Spray the inside of the tank with an aerosol rust-inhibiting oil.
Reinstall the fuel fill cap on the tank.

To assure proper performance after storage lasting more than one month, it is important to drain the carburetor.

WARNING

Petrol is highly flammable and explosive. You can be burned or seriously injured when handling fuel.

- Stop the engine and keep heat, sparks, and flame away.
- Refuel only outdoors.
- Wipe up spills immediately.

3. To prevent rusting in the cylinder, perform the following:
 - Remove the spark plug cap from the spark plug. Using tape or string, secure the cap to any convenient plastic body part so that it is positioned away from the spark plug.
 - Remove the spark plug from the engine. Do not connect the spark plug to the spark plug cap.
 - Pour a tablespoon (15*20 cm³) of clean engine oil into the cylinder and cover the spark plug hole with a piece of cloth.
 - Crank the engine several times to distribute the oil.
 - Reinstall the spark plug and spark plug cap.
4. Remove the battery. Store in an area protected from freezing temperatures and direct sunlight.
Slow charge the battery once a month.
5. Wash and dry the motorcycle. Wax all painted surfaces. Coat chrome with rustinhibiting oil.
6. Lubricate the drive chain (page 83).
7. Inflate the tyres to their recommended pressures. Place the motorcycle on blocks to raise both tyres off the ground.
8. Cover the motorcycle (don't use plastic or other coated materials) and store in an unheated area, free of dampness with a minimum of daily temperature variation. Do not store the motorcycle in direct sunlight.

REMOVAL FROM STORAGE

1. Uncover and clean the motorcycle.
2. Change the engine oil if more than 4 months have passed since the start of storage.
3. Charge the battery as required. Install the battery.
4. Drain any excess aerosol rust-inhibiting oil from the fuel tank. Fill the fuel tank with fresh petrol.
5. Perform all Pre-ride Inspection checks (page 46).
Test ride the motorcycle at low speeds in a safe riding area away from traffic.

SPECIFICATIONS

DIMENSIONS

Overall length	2,030 mm (79.9 in)
Overall width	745 mm (29.3 in)
Overall height	1,050 mm (41.3 in)
Wheelbase	1,370 mm (53.9 in)

CAPACITIES

Engine oil	After draining	1.5 ℓ (1.6 US qt , 1.3 Imp qt)
	After draining and oil filter exchange	1.5 ℓ (1.6 US qt , 1.3 Imp qt)
	After disassembly	1.8 ℓ (1.9 US qt , 1.6 Imp qt)
Fuel tank		16.0 ℓ (4.23 US gal , 3.52 Imp gal)
Fuel reserve		2.5 ℓ (0.66 US gal , 0.55 Imp gal)
Passenger capacity		Operator and one passenger

ENGINE

Bore and stroke	73.0 × 59.5 mm (2.87 × 2.34 in)
Compression ratio	9.3 : 1
Displacement	249 cm ³ (15.2 cu-in)
Spark plug	
Standard	CR8EH * 9S (NGK)
For extended high speed riding	CR9EH * 9S (NGK)
Spark plug gap	0.8 * 0.9 mm (0.03 * 0.04 in)
Idle speed	1,400 ± 100 min ⁻¹ (rpm)
Valve clearance (Cold)	
Intake	0.12 mm (0.005 in)
Exhaust	0.15 mm (0.006 in)

CHASSIS AND SUSPENSION

Caster	25°00'
Trail	99 mm (3.9 in)
Tyre size, Front	100/80 * 17M/C 52S PIRELLI MT75
Tyre size, Rear	130/70 * 17M/C 62S PIRELLI MT75
Tyre type	bias-ply, tubeless

POWER TRANSMISSION

Primary reduction	3.100
Gear ratio, 1st	2.769
2nd	1.882
3rd	1.333
4th	1.083
5th	0.923
6th	0.814
Final reduction	2.846

ELECTRICAL

Battery

12V – 6Ah

Generator

0.204kW/5,000 min⁻¹ (rpm)

LIGHTS

Headlight

12V – 60/55W

Brake/tail light

12V – 21/5W

Turn signal light

Front

12V – 16W × 2

Rear

12V – 16W × 2

Position light

12V – 5W

License light

12V – 5W

FUSE

Main fuse

30 A

Other fuse

5A, 10A

CATALYTIC CONVERTER

This motorcycle is equipped with a catalytic converter.

The catalytic converter contains precious metals that serve as catalysts, promoting chemical reactions to convert the exhaust gasses without affecting the metals.

The catalytic converter acts on HC, CO, and NOx. A replacement unit must be an original Honda part or its equivalent.

The catalytic converter must operate at a high temperature for the chemical reactions to take place. It can set on fire any combustible materials that come near it. Park your motorcycle away from high grasses, dry leaves, or other flammables.

A defective catalytic converter contributes to air pollution, and can impair your engine's performance. Follow these guidelines to protect your motorcycle's catalytic converter.

- Always use unleaded petrol. Even a small amount of leaded petrol can contaminate the catalyst metals, making the catalytic converter ineffective.
- Keep the engine tuned-up.
- Have your motorcycle diagnosed and replaced if it is misfiring, backfiring, stalling or otherwise not running properly.

NOISE CONTROL SYSTEM (AUSTRALIA ONLY)

TAMPERING WITH THE NOISE CONTROL SYSTEM IS PROHIBITED: Owners are warned that the law may prohibit : (a) The removal or rendering inoperative by any person other than for purposes of maintenance, repair, or replacement, of any device or element of design incorporated into any new vehicle for the purpose of noise control prior to its sale or delivery to the ultimate purchaser or while it is in use; and (b) the use of the vehicle after such device or element of design has been removed or rendered inoperative by any person.

