

# HONDA

OWNER'S MANUAL

CD250U

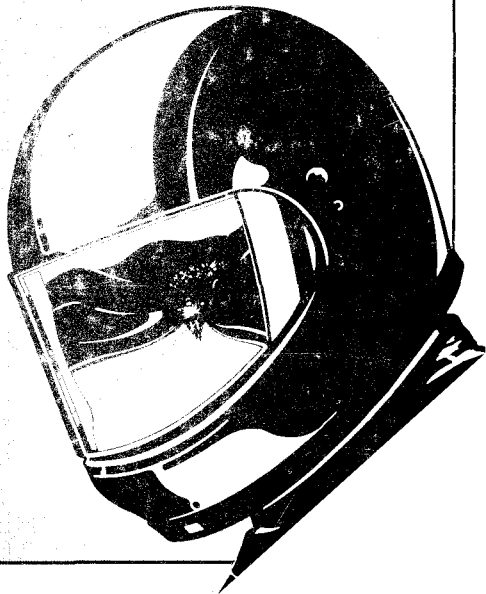

## IMPORTANT NOTICE

- **OPERATOR AND PASSENGER**

This motorcycle is designed to carry the operator and one passenger. Never exceed the maximum weight capacity as shown on the tyre information label.

- **ON-ROAD USE**

This motorcycle is designed to be used only on the road.

- **READ THIS OWNER'S MANUAL CAREFULLY**

Pay special attention to statements preceded by the following words:

**⚠ WARNING**

**Indicates a strong possibility of severe personal injury or death if instructions are not followed.**

**CAUTION:**

**Indicates a possibility of personal injury or equipment damage if instructions are not followed.**

**NOTE:** Gives helpful information.

This manual should be considered a permanent part of the motorcycle and should remain with the motorcycle when resold.

# HONDA CD250U OWNER'S MANUAL

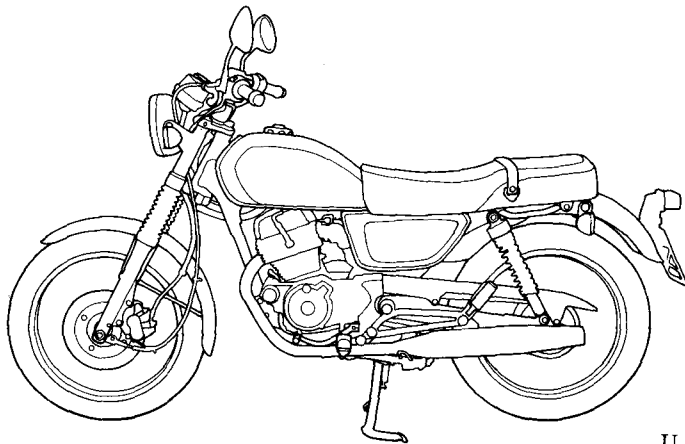

U type

All information in this publication is based on the latest production information available at the time of approval for printing. HONDA MOTOR CO., LTD. reserves the right to make changes at any time without notice and without incurring any obligation.

No part of this publication may be reproduced without written permission.

© Honda Motor Co., Ltd. 1988

## WELCOME

Thank you for purchasing this Honda motorcycle and welcome to the family of Honda motorcycle riders. To enjoy safer and more pleasant riding, become thoroughly familiar with this owner's manual **BEFORE YOU RIDE MOTORCYCLE**. Your safety depends not only on your own alertness and familiarity with the motorcycle, but also the motorcycle's mechanical condition. A pre-ride inspection before every outing and regular maintenance are essential.

When regular maintenance or repairs are required, remember that your authorized Honda dealer knows what it takes to keep your Honda going strong. If you have the required mechanical "know-how" and tools, your Honda dealer can supply you with an official Honda Service Manual to help you perform many maintenance and repair tasks.

Pleasant riding, and thank you for choosing a Honda.

- Following codes in this manual indicate each country.

E	England
U	Australia

- The specifications may vary with each locale.

# OPERATION

Page		Page	
1	MOTORCYCLE SAFETY	26	Right Handlebar Controls
1	Safe Riding Rules	27	Left Handlebar Controls
2	Protective Apparel		
3	Modifications	28	FEATURES (Not required for operation)
4	Loading and Accessories	28	Steering Lock
		29	Helmet Holder
6	PARTS LOCATION	30	Document Bag
9	Instruments and Indicators		
		31	OPERATION
11	MAJOR COMPONENTS (Information you need to operate this motorcycle)	31	Pre-ride Inspection
11	Suspension	32	Starting the Engine
12	Brakes	34	Running-in
16	Clutch	35	Riding
18	Fuel	37	Braking
22	Engine Oil	38	Parking
23	Tyres	38	Anti-theft Tips
25	ESSENTIAL INDIVIDUAL COMPONENTS		
25	Ignition Switch		

## **MAINTENANCE**

<b>Page</b>	
39	<b>MAINTENANCE</b>
40	Maintenance Schedule
42	Tool Kit
43	Serial Numbers
44	Colour Label
44	Maintenance Precautions
45	Air Cleaner
46	Crankcase Breather
47	Engine Oil
49	Spark Plugs
51	Idle Speed
52	Drive Chain
57	Front and Rear Suspension Inspection
57	Side Stand
58	Wheel Removal
62	Brake Pad Wear
63	Brake Shoe Wear

<b>Page</b>	
64	Battery
66	Fuse Replacement

## **68 CLEANING**

## **69 STORAGE GUIDE**

69	Storage
70	Removal from Storage

## **71 SPECIFICATIONS**

## **74 NOISE CONTROL SYSTEM**

# MOTORCYCLE SAFETY

## ⚠ WARNING

- \* **Motorcycle riding requires special efforts on your part to ensure your safety. Know these requirements before you ride:**

## SAFE RIDING RULES

1. Always make a pre-ride inspection (page 31) before you ride the motorcycle. You may prevent an accident or equipment damage.
2. Many accidents involve inexperienced riders. Most countries require a special motorcycle riding test or licence. Make sure you are qualified before you ride. **NEVER** lend your motorcycle to an inexperienced rider.
3. Many automobile/motorcycle accidents happen because the automobile driver does not “see” the motorcyclist.  
Make yourself conspicuous to help avoid the accident that wasn’t your fault:
  - Wear bright or reflective clothing.
  - Don’t ride in another motorist’s “blind spot.”
4. Obey all national and local laws and regulations.
  - Excessive speed is a factor in many accidents. Obey the speed limits, and **NEVER** travel faster than conditions warrant.
  - Signal before you make a turn or lane change. Your size and maneuverability can surprise other motorists.

5. Don't let other motorists surprise you. Use extra caution at intersections, parking lot entrances and exits, and driveways.
6. Keep both hands on the handlebars and both feet on the footpegs while riding. A passenger should hold on to the motorcycle or the operator with both hands and keep both feet on the passenger footpegs.

## **PROTECTIVE APPAREL**

1. Most motorcycle accident fatalities are due to head injuries: ALWAYS wear a helmet. You should also wear a face shield or goggles as well as boots, gloves, and protective clothing. A passenger needs the same protection.
2. The exhaust system becomes hot during operation, and it remains hot for a while after stopping the engine. Be careful not to touch the exhaust system while it is hot. Wear clothing that fully covers your legs.
3. Do not wear loose clothing which could catch on the control levers, footpegs, drive chain or wheels.

## MODIFICATIONS

### **▲** WARNING

- \* **Modification of the motorcycle, or removal of original equipment, may render the vehicle unsafe or illegal. Obey all national and local equipment regulations.**

## LOADING AND ACCESSORIES

### **▲ WARNING**

- \* **A motorcycle is sensitive to changes in weight distribution. Addition of accessories or cargo can impair the motorcycle's stability and performance. To prevent an accident, use extreme care when adding and riding with cargo and accessories. These general guidelines may help you decide whether, or how to equip your motorcycle.**

## Loading

The combined weight of the rider, passenger, cargo and additional accessories must not exceed the maximum weight capacity:

170 kg (375 lbs)

Cargo weight alone should not exceed:

9 kg (20 lbs)

1. Keep cargo and accessory weight low and close to the center of the motorcycle. Load weight equally on both sides to minimize imbalance. As weight is located further from the motorcycle's center of gravity, handling is proportionally affected.
2. Adjust tyre pressure (page 23) and rear suspension (page 11) to suit load weight and riding conditions.
3. Vehicle handling and stability can be adversely affected by loose cargo. Recheck cargo security and accessory mounts frequently.
4. Do not attach large or heavy items to the handlebars, front forks, or fender. Unstable handling or slow steering response may result.

## Accessories

Genuine Honda accessories have been specifically designed for and tested on this motorcycle. Because the factory cannot test all other accessories, you are personally responsible for proper selection, installation, and use of non-Honda accessories. Always follow the guidelines under Loading, and these:

1. Carefully inspect the accessory to make sure it does not obscure any lights, reduce ground clearance and banking angle, or limit suspension travel, steering travel or control operation.
2. Large fork-mounted fairings or windshields, or poorly designed or improperly mounted fairings can produce aerodynamic forces that cause unstable handling. Do not install fairings that decrease cooling air flow to the engine.
3. Accessories which alter your riding position by moving hands or feet away from controls may increase reaction time in an emergency.
4. Do not add electrical equipment that will exceed the motorcycle's electrical system capacity. A blown fuse could cause a dangerous loss of lights or engine power.
5. This motorcycle was not designed to pull a sidecar or trailer. Handling may be seriously impaired if so equipped.
6. Any modification of the cooling system may cause overheating and serious engine damage.

# PARTS LOCATION

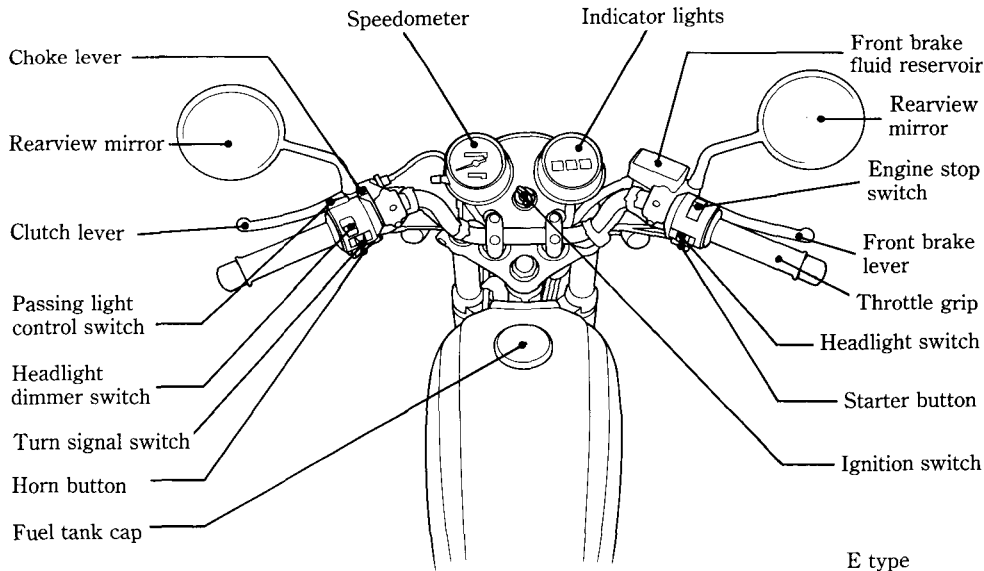

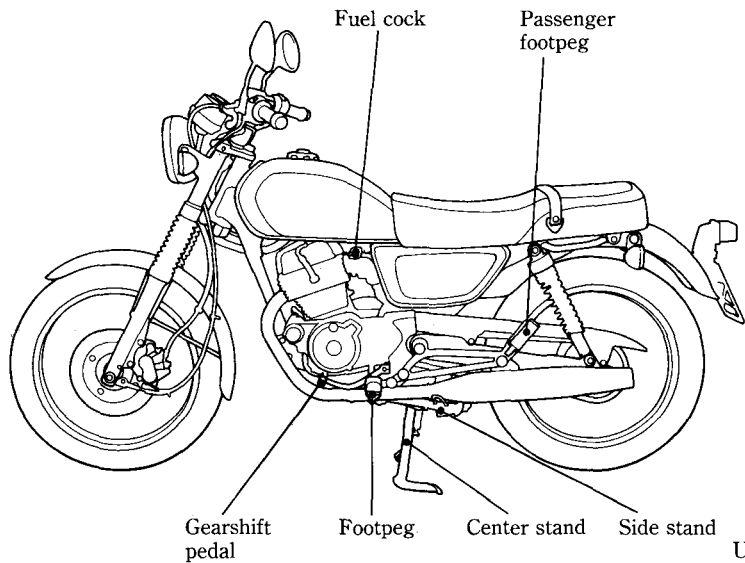

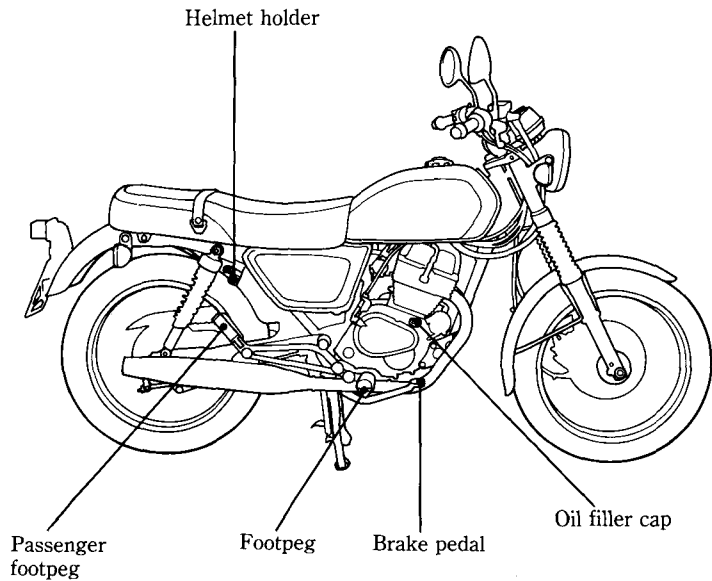

U type

## INSTRUMENTS AND INDICATORS

The indicators and warning lights are contained in the instrument panel. Their functions are described in the tables on the following pages.

- (1) Speedometer
- (2) Gear range indicators
- (3) Odometer
- (4) Tripmeter
- (5) Tripmeter reset knob
- (6) Neutral indicator
- (7) Turn signal indicator
- (8) High beam indicator

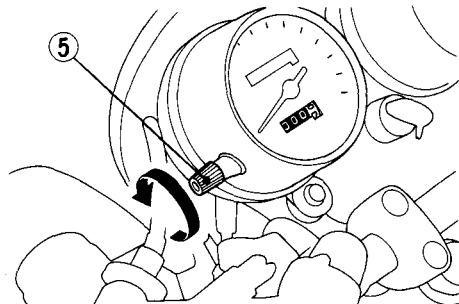
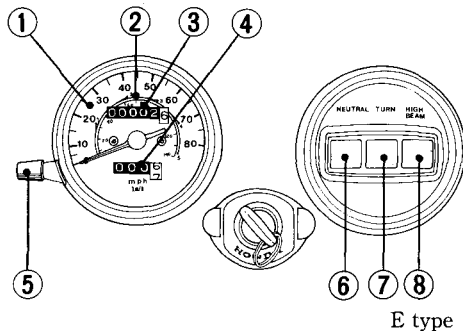

<b>Ref. No.</b>	<b>Description</b>	<b>Function</b>
1	Speedometer	Shows riding speed.
2	Gear range indicators	Indicate speed range for each gear.
3	Odometer	Shows accumulated mileage.
4	Tripmeter	Shows mileage per trip or section of route.
5	Tripmeter reset knob	Resets tripmeter to zero (0). Turn knob in direction shown.
6	Neutral indicator (green)	Lights when the transmission is in neutral.
7	Turn signal indicator (amber)	Flashes when either turn signal is operated.
8	High beam indicator (blue)	Lights when the headlight is on high beam.

## MAJOR COMPONENTS (Information you need to operate this motorcycle)

### ⚠ WARNING

\* If the Pre-ride Inspection (page 31) is not performed, severe personal injury or vehicle damage may result.

## SUSPENSION

### Rear Suspension

Each shock absorber (1) has five adjustment positions for different load or riding conditions. Use a Pin spanner (2) to adjust the rear shocks. Position I is for light loads and smooth road conditions. Positions II to V increase spring preload for a stiffer rear suspension, and can be used when the motorcycle is heavily loaded. Be certain to adjust both shock absorbers to the same position.

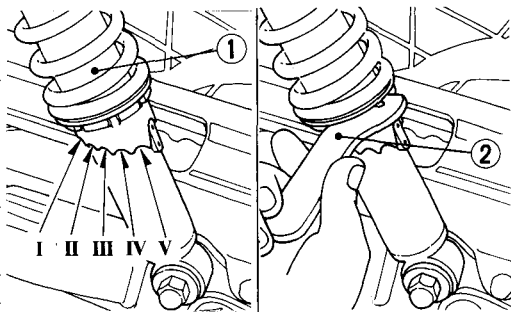

(1) Shock absorber

(2) Pin spanner

## BRAKES

### Front Brake

This motorcycle has hydraulic disc front brake. As the brake pads wear, brake fluid level drops, automatically compensating for wear.

There are no adjustments to perform, but fluid level and pad wear must be inspected periodically. The system must be inspected frequently to ensure there are no fluid leaks. If the control lever free travel becomes excessive and the brake pads are not worn beyond the recommended limit (page 62), there is probably air in the brake system and it must be bled. See your authorized Honda dealer for this service.

#### Brake Fluid Level:

#### **⚠ WARNING**

- \* **Brake fluid may cause irritation. Avoid contact with skin or eyes. In case of contact, flush thoroughly with water and call a doctor if your eyes were exposed.**

Check that the fluid level is above the LOWER level mark (1) with the motorcycle in an upright position.

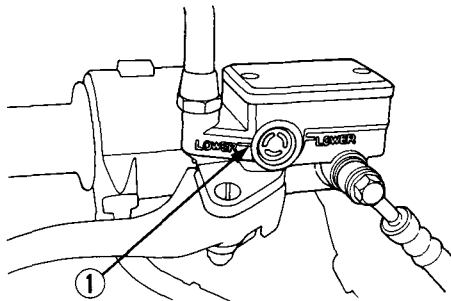

(1) LOWER level mark

Brake fluid must be added to the reservoir whenever the fluid level begins to reach the LOWER level mark (1). Remove the screws (2),

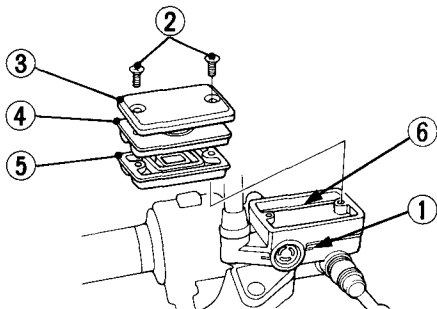

- (1) LOWER level mark (4) Diaphragm plate  
(2) Screws (5) Diaphragm  
(3) Reservoir cover (6) Upper level mark

reservoir cover (3), diaphragm plate (4) and diaphragm (5). Fill the reservoir with DOT 3 or DOT 4 BRAKE FLUID from a sealed container up to the upper level mark (6). Reinstall the diaphragm and cover. Tighten the screws securely.

**CAUTION:**

- \* **Handle brake fluid with care because it can damage plastic and painted surfaces.**
- \* **When adding brake fluid, be sure the reservoir is horizontal before the cap is removed or brake fluid may spill out.**
- \* **Use only DOT 3 or DOT 4 brake fluid from a sealed container.**
- \* **Never allow contaminants such as dirt or water to enter the brake fluid reservoir.**

Other Checks:

Make sure there are no fluid leaks. Check for deterioration or cracks in the hoses and fittings.

## Rear Brake

### Adjustment:

1. Place the motorcycle on its side or center stand.
2. Measure the distance the rear brake pedal (1) moves before the brake starts to take hold.

Free play should be:

20–30 mm (3/4–1-1/4 in)

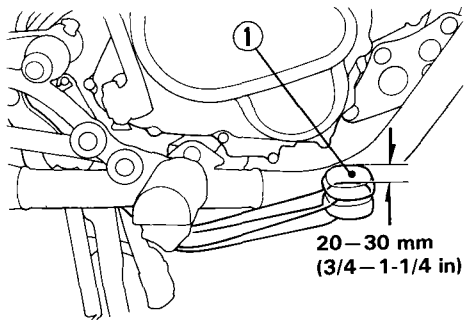

(1) Rear brake pedal

Make free play adjustments by turning the adjusting nut (2) at the brake arm.

### NOTE:

- \* Make sure the cut-out on the adjusting nut is seated on the brake arm pin (3) after making final free play adjustment.
- \* If proper adjustment cannot be obtained by this method, see your authorized Honda dealer.

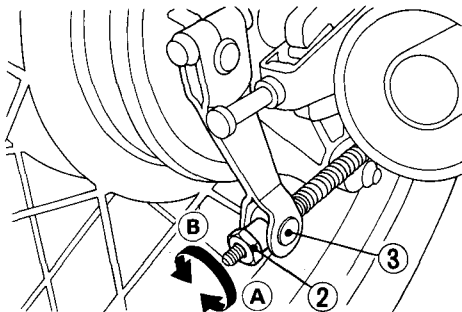

(2) Adjusting nut  
(3) Arm pin

(A) Decrease free play  
(B) Increase free play

3. Apply each brake several times and check for free wheel rotation when released.

Other Checks:

Make sure the brake rod, brake arm, spring and fasteners are in good condition.

## CLUTCH

Clutch adjustment may be required if the motorcycle stalls when shifting into gear or tends to creep; or if the clutch slips, causing acceleration to lag behind engine speed.

Minor adjustments can be made with the clutch cable adjuster (3) at the lever (1).

Normal clutch lever free play is:

10–20 mm (3/8–3/4 in)

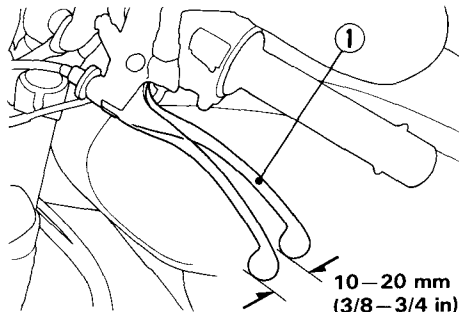

(1) Clutch lever

1. Pull back the rubber dust cover. Loosen the lock nut (2) and turn the adjuster (3). Tighten the lock nut (2) and check the adjustment.
2. If the adjuster is threaded out near its limit or if the correct free play cannot be obtained, loosen the lock nut (2) and turn in the cable adjuster (3) completely. Tighten the lock nut (2) and pull on the dust cover.

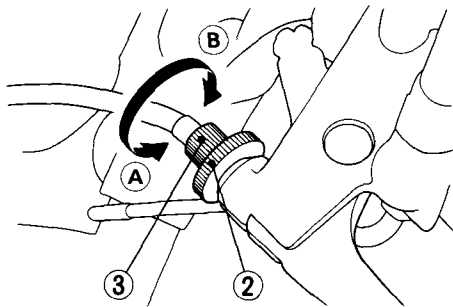

(2) Lock nut  
(3) Clutch cable  
adjuster

(A) Increase free play  
(B) Decrease free play

- At the lower end of the cable, loosen the lock nut (5). Turn the adjusting nut (4) to obtain the specified free play. Tighten the lock nut (5) and check the adjustment.
- Start the engine, pull in the clutch lever and shift into gear. Make sure the engine does not stall and the motorcycle does not creep. Gradually release the clutch lever and open the throttle. The motorcycle should start smoothly and accelerate gradually.

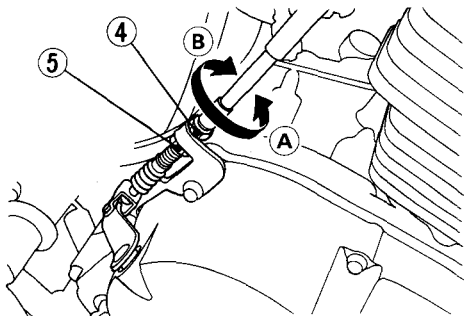

(4) Adjusting nut  
(5) Lock nut

(A) Increase free play  
(B) Decrease free play

#### NOTE:

- If proper adjustment cannot be obtained or the clutch does not work correctly, see your authorized Honda dealer.

#### Other Checks:

Check the clutch cable for kinks or signs of wear that could cause sticking or failure. Lubricate the clutch cable with a commercially available cable lubricant to prevent premature wear and corrosion.

## FUEL

### Fuel Cock

The three way fuel cock (1) is on the left side near the carburetor.

#### OFF

With the fuel cock in the OFF position, fuel cannot flow from the tank to the carburetors. Turn the valve off whenever the motorcycle is not in use.

#### ON

With the fuel cock in the ON position, fuel will flow from the main fuel supply to the carburetors.

#### RES

With the fuel cock in the RES position, fuel will flow from the reserve fuel supply to the carburetors. Use the reserve fuel only when the main supply is gone. Refill the tank as soon as possible after switching to RES.

The reserve fuel supply is:

1.8 l (0.5 US gal, 0.4 Imp gal)

#### **▲ WARNING**

- \* **To avoid running out of fuel that may result in a sudden stop, learn how to operate the fuel cock when riding the motorcycle.**
- \* **Be careful not to touch any hot engine parts while operating the fuel cock.**

#### NOTE:

- \* Do not operate this motorcycle with the fuel cock in the RES position after refueling. You may run out of fuel with no reserve.

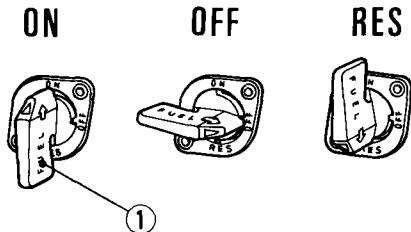

(1) Fuel cock

## Fuel Tank

The fuel tank capacity, including reserve, is:

10.0 ℓ (2.6 US gal, 2.2 Imp gal)

To open the fuel tank cap (1), insert the ignition key (2) and turn it clockwise. Then turn the fuel tank cap counterclockwise.

To close the fuel tank cap, align the latch in the cap with the slot in the filler neck.

Push cap into the filler neck until it snaps closed and locks. Remove the key and close the tank cap cover.

Use low-lead or unleaded petrol with an Octane number of 91 or higher.

### FOR AUSTRALIA ONLY

Use unleaded fuel with a research octane number of 91 or higher.

### CAUTION:

\* If “spark knock” or “pinking” occurs at a steady engine speed under normal load, change brands of petrol. If spark knock or pinking persists, consult your authorized Honda dealer. Failure to do so is considered misuse, and damage caused by misuse is not covered by Honda’s Limited Warranty.

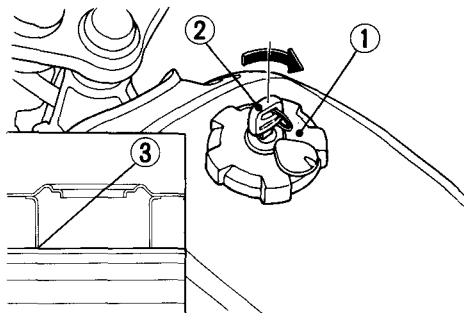

(1) Fuel tank cap

(2) Ignition key

(3) Filler neck

**⚠ WARNING**

- \* **Petrol is extremely flammable and is explosive under certain conditions. Refuel in a well-ventilated area with the engine stopped. Do not smoke or allow flames or sparks in the area where the engine is refueled or where petrol is stored.**
- \* **Do not overfill the tank (there should be no fuel in the filler neck (3)). After refueling, make sure the fuel cap is closed securely.**
- \* **Be careful not to spill fuel when refueling. Spilled fuel or fuel vapor may ignite. If any fuel is spilled, make sure the area is dry before starting the engine.**
- \* **Avoid repeated or prolonged contact with skin or breathing of vapor. KEEP OUT OF REACH OF CHILDREN.**

**Petrol Containing Alcohol**

If you decide to use a petrol containing alcohol (gasohol), be sure it's octane rating is at least as high as that recommended by Honda. There are two types of "gasohol": one containing ethanol, and the other containing methanol. Do not use petrol that contains more than 10% ethanol. Do not use petrol containing methanol (methyl or wood alcohol) that does not also contain cosolvents and corrosion inhibitors for methanol. Never use petrol containing more than 5% methanol, even if it has cosolvents and corrosion inhibitors.

**NOTE:**

- \* Fuel system damage or engine performance problem resulting from the use of fuels that contain alcohol is not covered under the warranty. Honda cannot endorse the use of fuels containing methanol since evidence of their suitability is as yet incomplete.
- \* Before buying fuel from an unfamiliar station, try to find out the fuel contains alcohol, if it does, confirm the type and percentage of alcohol used. If you notice any undesirable operating symptoms while using a petrol that contains alcohol, or one that you think contains alcohol, switch to a petrol that you know does not contain alcohol.

## ENGINE OIL

### Engine Oil Level Check

Check the engine oil level each day before riding the motorcycle.

The level must be maintained between the upper (2) and lower (3) level marks on the dipstick (1).

1. Start the engine and let it idle for a few minutes.
2. Stop the engine and put the motorcycle on its center stand on level ground.
3. After a few minutes, remove the oil filler cap/dipstick, wipe it clean, and reinsert the dipstick without screwing it in. The oil level should be between the upper (2) and lower (3) marks on the dipstick.
4. If required, add the specified oil up to the upper level mark (See page 47). Do not overfill.
5. Reinstall the oil filler cap/dipstick. Check for oil leaks.

### CAUTION:

\* Running the engine with insufficient oil can cause serious engine damage.

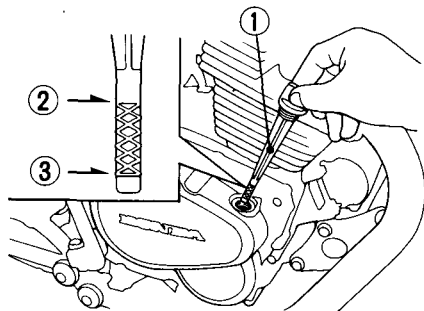

- (1) Oil filler cap/dipstick
- (2) Upper level mark
- (3) Lower level mark

## TYRES

Proper air pressure will provide maximum stability, riding comfort and tyre life.

Check tyre pressure frequently and adjust if necessary.

### NOTE:

\* Tyre pressure should be checked before you ride while the tyres are "cold".

Select the right replacement tyre in accordance with the following specifications.

		Front	Rear
Tyre size		3.00-17-4PR	3.25-17-6PR
Cold tyre pressures kPa (kg/cm <sup>2</sup> , psi)	Rider only	200 (2.00, 29)	200 (2.00, 29)
	Rider and one passenger	200 (2.00, 29)	280 (2.80, 41)
Tyre brand BRIDGESTONE		L301	RS10

Check the tyre for cuts, imbedded nails or other sharp objects. See your authorized Honda Dealer for replacement of damaged tyre or punctured inner tubes.

**▲ WARNING**

- \* **Do not attempt to patch a damaged tyre or inner tube. Wheel balance and tyre reliability may be impaired.**
- \* **Improper tyre inflation will cause abnormal tread wear and create a safety hazard. Underinflation may result in the tyre slipping on, or coming off of the rims, causing tyre deflation that may result in a loss of vehicle control.**
- \* **Operation with excessively worn tyre is hazardous and will adversely affect traction and handling.**
- \* **The use of tyres other than those listed on the tyre information label may adversely affect handling.**

Replace tyre before tread depth at the center of the tyre reaches the following limit:

Minimum tread depth
Front: 1.5 mm (0.06 in)
Rear: 2.0 mm (0.08 in)

# ESSENTIAL INDIVIDUAL COMPONENTS

## IGNITION SWITCH

The ignition switch (1) is below the indicator panel.

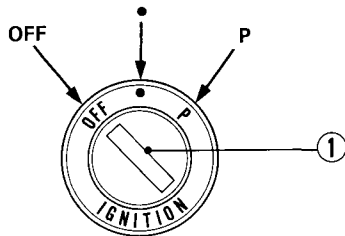

(1) Ignition switch

Key Position	Function	Key Removal
P (parking)	For parking the motorcycle near traffic. The taillight and position light are on, but all other lights are off. The engine cannot be started.	Key can be removed
● (red dot)	Engine and lights can be operated.	Key cannot be removed
OFF	Engine and lights cannot be operated.	Key can be removed

## RIGHT HANDLEBAR CONTROLS

### Engine Stop Switch

The engine stop switch (1) is next to the throttle grip. When the switch is in the RUN position, the engine will operate. When the switch is in the OFF position, the engine will not operate. This switch is intended primarily as a safety or emergency switch and should normally remain in the RUN position.

### Headlight Switch

The headlight switch (3) has three positions, "H", "P" and "OFF" marked by a dot to the right of "P".

H: Headlight, taillight, position light and meter lights on.

P: Position light, taillight and meter lights on.

OFF (dot): Headlight, taillight, position light and meter lights off.

### Starter Button

The starter button (2) is below the engine stop switch (1).

When you press in the button, the starter cranks the engine.

See pages 32–33 for "Starting Procedure."

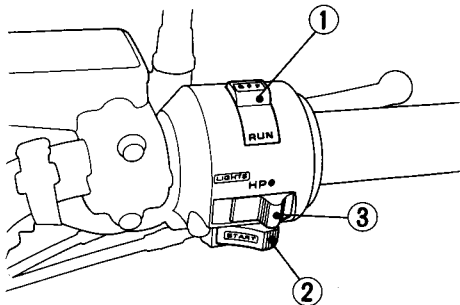

(1) Engine Stop switch (3) Headlight switch  
(2) Starter Button

## LEFT HANDLEBAR CONTROLS

### Headlight Dimmer Switch (1)

Push the dimmer switch to "HI" to select high beam or to "LO" to select low beam.

### Passing Light Control Switch (2)

When this switch is pressed, the headlight flashes on to signal approaching cars or when passing.

### Turn Signal Switch (3)

Move to L to signal a left turn, R to signal a right turn. Press to turn signal off.

### Horn Button (4)

Press the button to sound the horn.

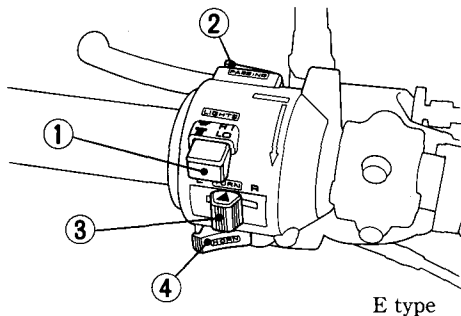

- (1) Headlight dimmer switch
- (2) Passing light control switch
- (3) Turn signal switch
- (4) Horn button

## FEATURES

### (Not required for operation)

#### STEERING LOCK

The steering lock (1) is on the steering stem.

#### To Lock:

Turn the handlebar all the way to the left or right and insert the key into the lock, turn the key clockwise and remove it.

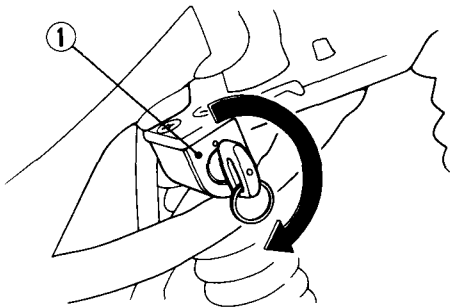

(1) Steering lock

## HELMET HOLDER

The helmet holder (1) is on the right side below the seat. Insert the ignition key (2) and turn it counterclockwise to unlock. Hang your helmet on the holder pin (3) and push it in to lock. Remove the key.

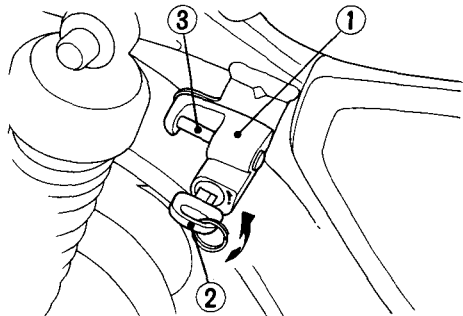

(1) Helmet holder  
(2) Ignition key

(3) Holder pin

### **▲ WARNING**

- \* The helmet holder is designed for helmet security while parked. Do not ride with a helmet attached to the holder; the helmet may interfere with safe operation and result in loss of control.

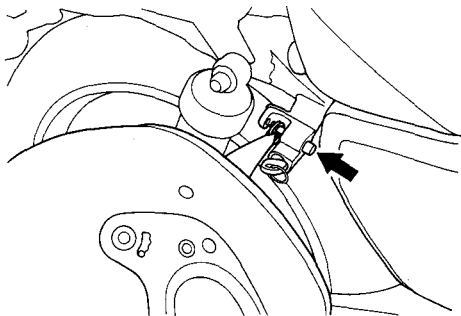

## DOCUMENT BAG

The document bag (1) is attached to the left side cover (2).

The owner's manual and other documents should be stored in the vinyl bag. When washing your motorcycle, be careful not to flood this area with water.

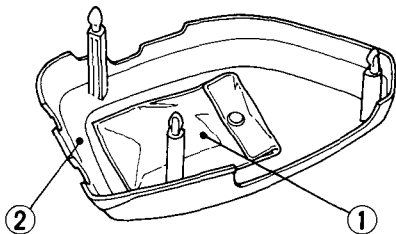

(1) Document bag

(2) Left side cover

# OPERATION

## PRE-RIDE INSPECTION

### **▲ WARNING**

**\* If the Pre-ride Inspection is not performed, severe personal injury or vehicle damage may result.**

Inspect your motorcycle every day before you ride it. The items listed here will only take a few minutes to inspect, and in the long run they can save time, expense, and possibly your life.

1. Engine oil level—add engine oil if required (page 22). Check for leaks.
2. Fuel level—fill fuel tank when necessary (page 18). Check for leaks.
3. Front and rear brakes—check operation; make sure there is no brake fluid leakage. Adjust free play if necessary (pages 12–15).

4. Tyres—check condition and pressure (pages 23–24).
5. Drive chain—check condition and slack (pages 52–53). Adjust and lubricate if necessary.
6. Throttle—check for smooth opening and closing in all steering positions.
7. Lights and horn—check that headlight, tail/stoplight, turn signals, indicators and horn function properly.
8. Engine stop switch—check for proper function (page 26).
9. Side stand—check for proper function (page 57).
10. Battery electrolyte—check the level and add if necessary (page 64).

Correct any discrepancy before you ride. Contact your authorized Honda dealer for assistance if you cannot correct the problem.

## STARTING THE ENGINE

### NOTE:

- \* Do not use the electric starter for more than 5 seconds at a time. Release the starter button for approximately 10 seconds before pressing it again.
- \* The electric starter will work when the transmission is in gear with the clutch disengaged.

### **▲ WARNING**

- \* **Never run the engine in a closed area. The exhaust contains poisonous carbon monoxide gas that may cause loss of consciousness and lead to death.**

### Preparation

1. Make sure the transmission is in neutral and the fuel cock is ON.
2. Insert the key in the ignition switch and turn to ON. The neutral indicator (green) should go on.
3. Make sure the engine stop switch is in RUN.

### Starting Procedure

1. Pull the choke lever (1) back all the way to the fully open position (B), if the engine is cold.
2. Press the starter button, leaving the throttle closed.
3. Warm up the engine by opening and closing the throttle until it runs smoothly, with the choke closed.

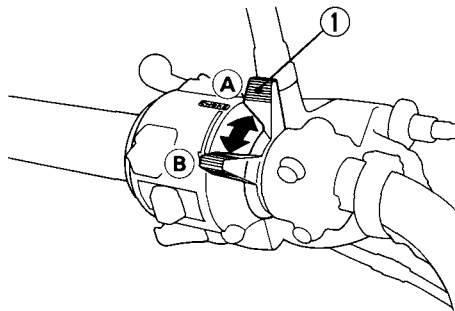

(1) Choke lever

(A) Fully Closed

(B) Fully Open

E type

**NOTE:**

- \* Do not open the throttle when starting the engine with the choke open. This will lean the mixture, resulting in hard starting.

**Flooded Engine**

If the engine fails to start after repeated attempts, it may be flooded with excess fuel. To clear a flooded engine, turn the engine stop switch OFF and push the choke lever forward to Fully Closed (A). Open the throttle fully and crank the engine for 5 seconds. Wait 10 seconds, then turn the engine stop switch ON and follow the Starting Procedure (page 32).

## **RUNNING-IN**

During the first 1,000 km (600 miles), avoid full throttle use and never labour the engine. Do not operate at any one speed for prolonged periods. During initial running-in, newly machined surfaces will be in contact with each other and these surfaces will wear in quickly.

Running-in maintenance at 1,000 km (600 miles) is designed to compensate for this initial minor wear. Timely performance of the running-in maintenance will ensure optimum service life and performance from the engine.

## RIDING

### ⚠ WARNING

- \* **Review Motorcycle Safety (pages 1—4) before you ride.**
- \* **Make sure the side stand is fully retracted before riding the motorcycle. If the stand is extended, it may interfere with control during a left turn.**

### NOTE:

- \* Make sure the function of the side stand mechanism. (See MAINTENANCE SCHEDULE on page 40 and explanation for SIDE STAND on page 57.)
1. Warm up the engine.
  2. With the engine idling, squeeze the clutch lever and shift into low (1st) by depressing the gear shift pedal.
  3. Slowly release the clutch lever while gradually picking up speed. Coordination of these two operations will assure a smooth start.
  4. When the motorcycle attains smooth forward motion, slow down the engine, squeeze the clutch again and shift into 2nd by raising the shift-pedal. Do the same for the other gears.

5. Coordinate the throttle and brakes for smooth deceleration.
6. Both front and rear brakes should be used at the same time and should not be applied strongly enough to lock the wheel, or braking effectiveness may be greatly reduced and control of the motorcycle be difficult.

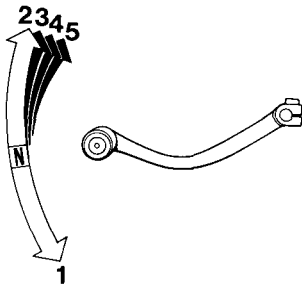

**⚠ WARNING**

- \* **Do not downshift when traveling at a speed that would force the engine to overrev in the next lower gear; the rear wheel may lose traction, resulting in a possible loss of vehicle control.**

**CAUTION:**

- \* **Do not shift gears without disengaging the clutch and closing the throttle. The engine and drive train could be damaged by overspeed and shock.**
- \* **Do not tow the motorcycle or coast for long distances while the engine is off. The transmission will not be properly lubricated and damage may result.**

**NOTE:**

- \* The battery will not charge while the engine speed is below  $1,500 \text{ min}^{-1}$  (rpm). Avoid idling for prolonged periods, or continuous operation below  $1,500 \text{ min}^{-1}$  (rpm).

## **BRAKING**

1. For normal braking, gradually apply both front and rear brakes while downshifting to suit your road speed.
2. For maximum deceleration, close the throttle and apply the front and rear brakes firmly. Disengage the clutch before the motorcycle stops.

### **▲ WARNING**

- \* **Independent use of only the front or rear brake reduces stopping performance. Extreme braking may cause either wheel to lock, reducing control of the motorcycle.**
- \* **When possible, reduce speed or brake before entering a turn; closing the throttle or braking in mid-turn may cause wheel slip. Wheel slip will reduce control of the motorcycle.**
- \* **When riding in wet or rainy conditions, or on loose surfaces, the ability to maneuver and stop will be reduced. All of your actions should be smooth under these conditions. Sudden acceleration, braking or turning may cause loss of control. For your safety, exercise extreme caution when braking, accelerating or turning.**
- \* **When descending a long, steep grade, use engine compression braking by downshifting, with intermittent use of both brakes. Continuous brake application can overheat the brakes and reduce their effectiveness.**
- \* **Riding with your foot resting on the brake pedal or your hands on the brake lever may actuate the brakelight, giving a false indication to other drivers. It may also overheat the brake, reducing effectiveness.**

## PARKING

1. After stopping the motorcycle, shift the transmission into neutral, turn the fuel cock OFF, turn the handlebar fully to the left, turn the ignition switch OFF and remove the key.
2. Use the side or center stand to support the motorcycle while parked.

### CAUTION:

- \* **Park the motorcycle on firm, level ground to prevent it from falling over.**
  - \* **If you park on a slight incline, aim the front of the motorcycle uphill to reduce the possibility of rolling off the side stand or overturning.**
3. Lock the steering to help prevent theft (page 38).

### NOTE:

- \* When stopping for a short time near traffic at night, the ignition switch may be turned to P and the key removed. This will turn on the taillight to make the motorcycle more visible to traffic. The battery will discharge if the ignition switch is left at P for too long.

## ANTI-THEFT TIPS

1. Always lock the steering and never leave the key in the steering lock. This sounds simple but people do forget.
2. Be sure the registration information for your motorcycle is accurate and current.
3. Park your motorcycle in a locked garage whenever possible.
4. Use an additional anti-theft device of good quality.
5. Put your name, address, and phone number in this Owner's Manual and keep it on your motorcycle at all times. Many times stolen motorcycles are identified by information in the Owner's Manuals that are still with them.

NAME: \_\_\_\_\_

ADDRESS: \_\_\_\_\_

\_\_\_\_\_

\_\_\_\_\_

PHONE NO.: \_\_\_\_\_

## **MAINTENANCE**

- When service is required, remember that your authorized Honda dealer knows your motorcycle best and is fully equipped to maintain and repair it. The scheduled maintenance may also be performed by a qualified service facility that normally does this kind of work; or you may perform most of the work yourself if you are mechanically qualified and have the proper tools and service data.
- These instructions are based on the assumption that the motorcycle will be used exclusively for its designed purpose. Sustained high speed operation, or operation in unusually wet or dusty conditions, will require more frequent service than specified in the MAINTENANCE SCHEDULE. Consult your authorized Honda dealer for recommendations applicable to your individual needs and use.

## MAINTENANCE SCHEDULE

The following items require some mechanical knowledge. Certain items (particularly those marked \* and \*\*) may require more technical information and tools. Consult your authorized Honda Dealer. Perform the Pre-ride Inspection at each scheduled maintenance period.

I: INSPECT AND CLEAN, ADJUST, LUBRICATE OR REPLACE IF NECESSARY

C: CLEAN R: REPLACE A: ADJUST L: LUBRICATE

ITEM	FREQUENCY	WHICHEVER →		ODOMETER READING [NOTE (1)]							REFER TO PAGE
		COMES FIRST ↓	x 1,000 km	1	6	12	18	24	30	36	
			x 1,000 mi	0.6	4	8	12	16	20	24	
	NOTE	MONTH		6	12	18	24	30	36		
* FUEL LINE						I		I		I	—
* FUEL STRAINER SCREEN					C	C	C	C	C	C	—
* THROTTLE OPERATION						I		I		I	—
* CARBURETOR CHOKE						I		I		I	—
AIR CLEANER	(NOTE 2)							R		R	45
CRANKCASE BREATHER	(NOTE 3)				C	C	C	C	C	C	46
SPARK PLUG					I	R	I	R	I	R	49-50
* VALVE CLEARANCE				I	I	I	I	I	I	I	—
ENGINE OIL				R	R	R	R	R	R	R	47-48
** ENGINE OIL STRAINER SCREEN						C		C		C	—
* CARBURETOR SYNCHRONIZATION						I		I		I	—
* CARBURTOR IDLE SPEED				I	I	I	I	I	I	I	51

ITEM	FREQUENCY	WHICHEVER COMES FIRST ↓ NOTE	ODOMETER READING [NOTE (1)]								REFER TO PAGE	
			↔	x 1,000 km	I	6	12	18	24	30		36
			MONTH	0.6	4	8	12	16	20	24		
DRIVE CHAIN			I, L EVERY 1,000 km (600 mi)								52-56	
BATTERY				I	I	I	I	I	I	64-65		
BRAKE FLUID		(NOTE 4)		I	I	R	I	I	R	12		
BRAKE SHOE/PADS WEAR				I	I	I	I	I	I	62-63		
BRAKE SYSTEM			I		I		I		I	12-15		
* BRAKE LIGHT SWITCH					I		I		I	—		
* HEADLIGHT AIM					I		I		I	—		
CLUTCH SYSTEM			I	I	I	I	I	I	I	15-16		
SIDE STAND					I		I		I	57		
* SUSPENSION					I		I		I	57		
* NUTS, BOLTS, FASTENERS			I		I		I		I	—		
** WHEELS/TYRES			I	I	I	I	I	I	I	—		
** STEERING HEAD BEARINGS			I		I		I		I	—		

\* Should be serviced by an authorized HONDA dealer, unless the owner has proper tools and service data and is mechanically qualified. Refer to the official HONDA service manual.

\*\* In the interest of safety, we recommend these items be serviced ONLY by an authorized HONDA dealer.

NOTES:

1. At higher odometer reading, repeat at the frequency interval established here.
2. Service more frequently when riding in unusually wet or dusty areas.
3. Service more frequently when riding in rain or at full throttle.
4. Replace every 2 years, or at indicated odometer interval, whichever comes first. Replacement requires mechanical skill.

## TOOL KIT

The tool kit (1) is in the tool compartment behind the left side cover. Some roadside repairs, minor adjustments and parts replacement can be performed with the tools contained in the kit.

- 8 x 12 mm open end wrench
- 10 x 12 mm open end wrench
- 14 x 17 mm open end wrench
- Pliers
- No. 2 screwdriver
- No. 2 Phillips screwdriver
- Screwdriver handle
- 12 mm box end wrench
- 22 mm box end wrench
- Pin spanner
- Spark plug wrench
- Tool bag

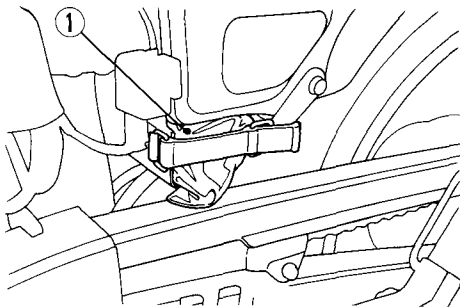

(1) Tool kit

## SERIAL NUMBERS

The frame and engine serial numbers are required when registering your motorcycle. They may also be required by your dealer when ordering replacement parts.

Record the numbers here for your reference.

FRAME NO. \_\_\_\_\_

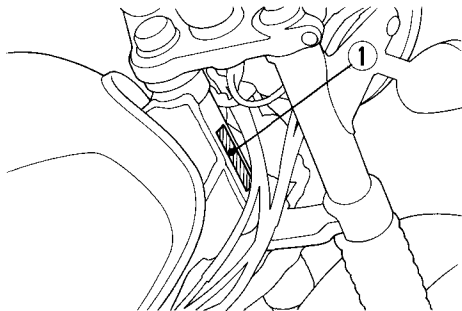

(1) Frame number

The frame number (1) is stamped on the right side of the steering head.

The engine number (2) is stamped on the right side of the crankcase.

ENGINE NO. \_\_\_\_\_

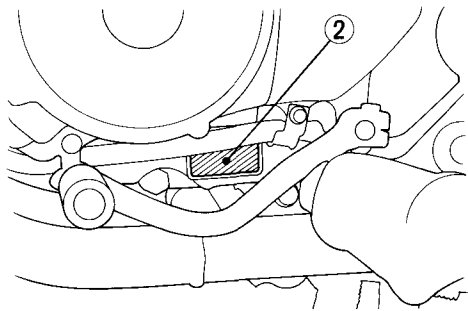

(2) Engine number

## COLOUR LABEL

The colour label (1) is attached to the frame behind the left side cover. It is helpful when ordering replacement parts. Record the colour and code here for your reference.

COLOUR \_\_\_\_\_

CODE \_\_\_\_\_

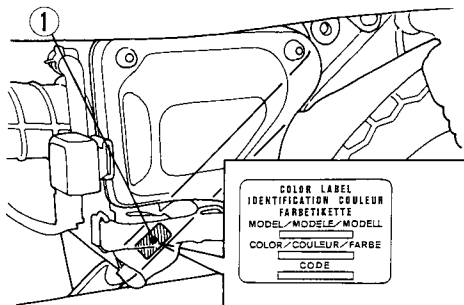

(1) Colour label

## MAINTENANCE PRECAUTIONS

### ▲ WARNING

- \* If your motorcycle is overturned or involved in a collision, inspect control levers, cable, brake hoses, caliper, accessories, and other vital parts for damage. Do not ride the motorcycle if damage impairs safe operation. Have your authorized Honda dealer inspect the major components, including frame, suspension and steering parts, for misalignment and damage that you may not be able to detect.
- \* Stop the engine and support the motorcycle securely on a firm, level surface before performing any maintenance.
- \* Use new, genuine Honda parts or their equivalent for maintenance and repair. Parts which are not of equivalent quality may impair the safety of your motorcycle.

## AIR CLEANER

(Refer to the maintenance precautions on page 44).

The air cleaner should be serviced at regular intervals (page 40). Service more frequently when riding in unusually wet or dust areas.

1. Remove the left side cover.
2. Remove the rubber band (1).
3. Remove the air cleaner cover nuts (2) and the cover (3).

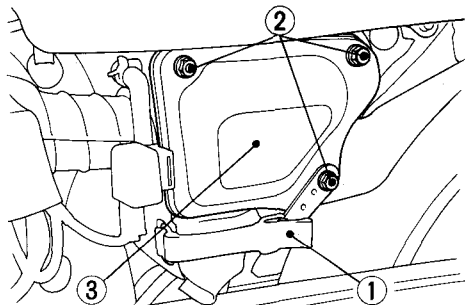

(1) Rubber band  
(2) Nuts

(3) Air cleaner cover

4. Pull out the tube (4) from the air cleaner element (5).
5. Pull out the element retainer (6) and remove the air cleaner element.
6. Install a new air cleaner element.
7. Install the removed parts in reverse order of removal.

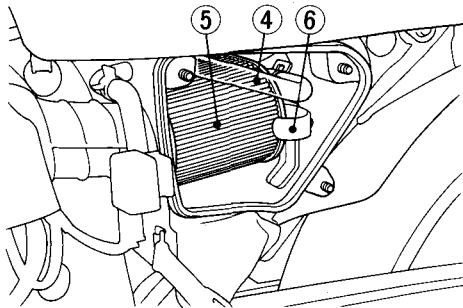

(4) Tube  
(5) Air cleaner element  
(6) Element retainer

## CRANKCASE BREATHER

(Refer to the maintenance precaution on page 44).

1. Remove the drain plug (1) from the tube and drain deposits.
2. Reinstall the drain plug.

### NOTE:

- \* Service more frequently when ridden in rain or at full throttle.

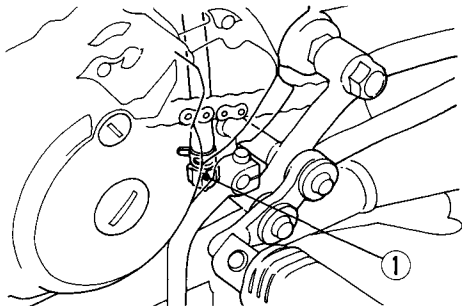

(1) Drain plug

## ENGINE OIL

(Refer to the maintenance precautions on page 44).

### Engine Oil

Good engine oil has many desirable qualities. Use only high detergent, quality motor oil certified on the container to meet or exceed requirements for service SE or SF. It is not necessary to use additives.

### Viscosity:

Viscosity grade of engine oil should be based on average atmospheric temperature in your riding area. The following provides a guide to the selection of the proper grade or viscosity of oil to be used at various atmospheric temperatures.

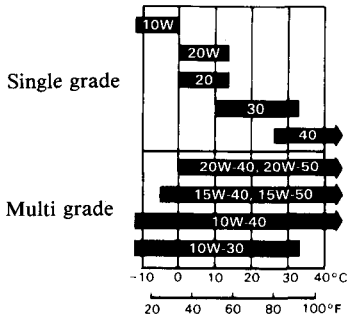

## Engine Oil

Engine oil quality is the chief factor affecting engine service life. Change the engine oil as specified in the maintenance schedule (page 40).

### NOTE:

- \* Change engine oil with the engine at normal operating temperature and the motorcycle on its side stand to assure complete and rapid draining.
1. Remove the oil filler cap/dipstick and drain plug (1) to drain the oil.

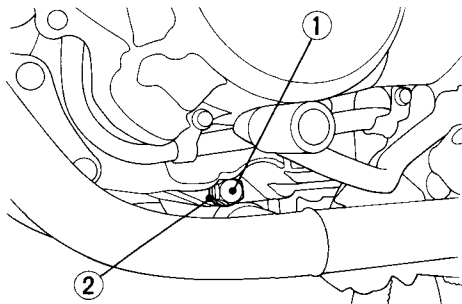

(1) Drain plug

(2) Sealing washer

### **▲ WARNING**

- \* **A warmed-up engine and the oil in it are hot; be careful not to burn yourself.**
2. Check that the sealing washer on the drain plug is in good condition and install the plug.  
Oil Drain Plug Torque:  
35 N·m (3.5 kg-m, 26 ft-lb)
  3. Fill the crankcase with the recommended grade oil; approximately:  
1.3 ℓ (1.4 US qt, 1.1 Imp qt)
  4. Install the oil filler cap/dipstick.
  5. Start the engine and let it idle for a 2–3 minutes.
  6. Stop the engine and check that the oil level is at the upper level mark on the dipstick with the motorcycle upright on firm, level ground. Make sure there are no oil leaks.

#### NOTE:

- \* When running in very dusty conditions, oil changes should be performed more frequently than specified in the maintenance schedule.
- \* Please dispose of used engine oil in a manner that is compatible with the environment. We suggest you take it in a sealed container to your local service station for reclamation. Do not throw it in the rubbish or pour it on the ground.

#### CAUTION:

- \* **Used engine oil may cause skin cancer if repeatedly left in contact with the skin for prolonged periods. Although this is unlikely unless you handle used oil on a daily basis, it is still advisable to thoroughly wash your hands with soap and water as soon as possible after handling used oil.**

#### SPARK PLUGS

(Refer to maintenance precautions on page 44).

Recommended plugs:

Standard:

CR6HSA (NGK)

U20FSR-U (ND)

For cold climate: (Below 5°C/41°F)

CR5HSA (NGK)

U16FSR-U (ND)

For extended high speed riding:

CR7HSA (NGK)

U22FSR-U (ND)

1. Disconnect the spark plug caps from the spark plugs.
2. Clean any dirt from around the spark plug bases. Remove the spark plugs using the plug wrench furnished in the tool kit.

3. Inspect the electrodes and center porcelain for deposits, erosion or carbon fouling. If the erosion or deposit is heavy, replace the plug. Clean a carbon or wet-fouled plug with a plug cleaner, otherwise use a wire brush.
4. Check the spark plug gap (1) using a wire-type feeler gauge. If adjustment is necessary, bend the side electrode (2) carefully.

The gap should be:

0.6–0.7 mm (0.024–0.028 in)

Make sure the plug washer is in good condition.

5. With the plug washer attached, thread the spark plug in by hand to prevent cross-threading.
6. Tighten a new spark plug 1/2 turn with a spark plug wrench to compress the washer. If you are reusing a plug, it should only take 1/8–1/4 turn after the plug seats.
7. Reinstall the spark plug caps.

**CAUTION:**

- \* The spark plug must be securely tightened. An improperly tightened plug can become very hot and possibly damage the engine.
- \* Never use a spark plug with an improper heat range. Severe engine damage could result.

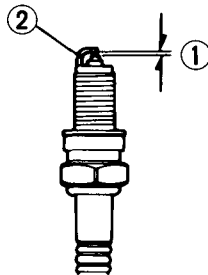

(1) Spark plug gap

(2) Side electrode

## IDLE SPEED

(Refer to the maintenance precaution on page 44).

The idle speed adjustment procedure given here should only be used when changes in altitude affect normal idle speed as set by your dealer. See your authorized Honda dealer for regularly scheduled carburetor adjustments, including individual carburetor adjustment and synchronization.

### NOTE:

\* The engine must be at normal operating temperature for accurate idle speed adjustment. Ten minutes of stop-and-go riding is sufficient.

1. Warm up the engine, and shift to neutral and place the motorcycle on its center stand.
2. Adjust idle speed with the throttle stop screw (1).

Idle Speed:

$1,300 \pm 100 \text{ min}^{-1}$  (rpm) (In neutral)

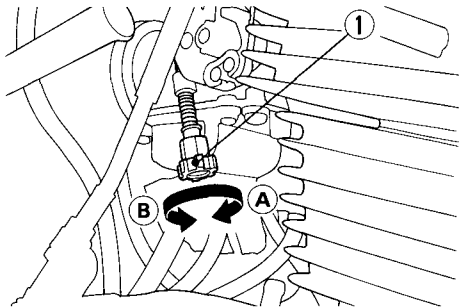

(1) Throttle stop screw      (A) Increase  
(B) Decrease

## DRIVE CHAIN

(Refer to maintenance precautions on page 44). The service life of the drive chain is dependent upon proper lubrication and adjustment. Poor maintenance can cause premature wear or damage to the drive chain and sprockets.

The drive chain should be checked and lubricated as part of the Pre-ride Inspection (page 31). Under severe usage, or when the motorcycle is ridden in unusually dusty areas, more frequent maintenance will be necessary.

### Inspection :

1. Turn the engine off, place the motorcycle on its center stand, and shift the transmission into neutral.
2. Check slack in the lower drive chain run mid-way between the sprockets.

Drive chain slack should be adjusted to allow the following vertical movement by hand:

15–25 mm (5/8–1 in)

Rotate the rear wheel and check drive chain slack as the wheel turns.

Drive chain slack should remain constant as the wheel rotates. If the chain is slack only in certain sections, some links are kinked and binding. Binding can frequently be eliminated by lubrication.

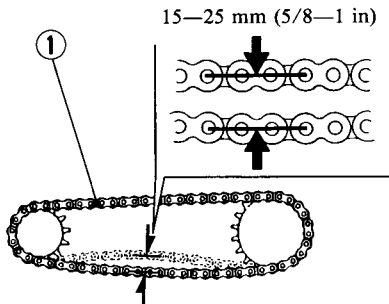

(1) Drive chain

3. Rotate the rear wheel slowly and inspect the drive chain and sprockets for any of the following conditions:

#### DRIVE CHAIN

- \* Damaged Rollers
- \* Loose Pins
- \* Dry or Rusted Links
- \* Kinked or Binding Links
- \* Excessive Wear
- \* Improper Adjustment
- \* Missing O-rings

#### SPROCKETS

- \* Excessively Worn Teeth
- \* Broken or Damaged Teeth

A drive chain with damaged rollers, loose pins, or missing O-rings must be replaced. A chain which appears dry, or shows signs of rust, requires supplementary lubrication. Kinked or binding links should be thoroughly lubricated and worked free. If links cannot be freed, the chain must be replaced.

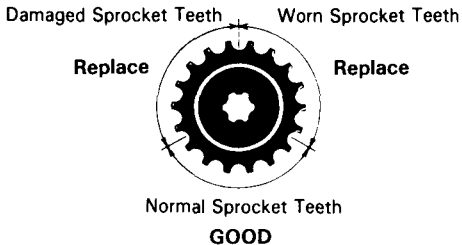

### Adjustment:

Drive chain slack should be checked and adjusted, if necessary, every 1,000 km (600 miles). When operated at sustained high speeds or under conditions of frequent rapid acceleration, the chain may require more frequent adjustment.

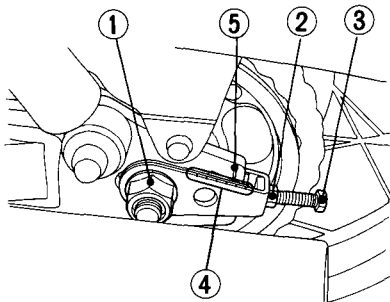

(1) Axle nut  
(2) Lock nut  
(3) Drive chain  
adjusting bolt

(4) Index mark  
(5) Swingarm index  
mark

If the drive chain requires adjustment, the procedure is as follows:

1. Place the motorcycle on its center stand with the transmission in neutral and the ignition switch off.
2. Loosen the axle nut (1).
3. Loosen the lock nuts (2) on both adjusting bolts (3).
4. Turn both adjusting bolts an equal number of turns until the correct drive chain slack is obtained. Turn the adjusting bolts clockwise to tighten the chain, or counterclockwise to provide more slack. Adjust the chain slack at a point midway between the drive sprocket and the rear wheel sprocket. Rotate the rear wheel and recheck slack at other sections of the chain.

Chain slack should be:

15–25 mm (5/8–1 in)

5. Check rear axle alignment by making sure the chain adjuster index marks (4) align with the swingarm index marks (5).

Both left and right marks should correspond. If the axle is misaligned, turn the left or right adjusting bolt until the marks correspond on both sides of the swingarm index marks and recheck chain slack.

6. Tighten the axle nut to:  
90 N·m (9.0 kg·m, 65 ft·lb)
7. Tighten the adjusting bolts lightly, then tighten the lock nuts on each side of the swingarm by holding the adjusting bolts with a spanner.
8. Rear brake pedal free play is affected when repositioning the rear wheel to adjust drive chain slack. Check rear brake pedal free play and adjust as necessary.

#### Wear inspection:

Check the chain wear label when adjusting the chain. If the red zone (6) on the label aligns with the rear of the swingarm after the chain has been adjusted to the proper slack, the chain is excessively worn and must be replaced. The proper slack is:

15–25 mm (5/8–1 in)

#### **CAUTION:**

- \* **Damage to the bottom part of the frame may be caused by excessive drive chain slack of more than:  
50 mm (2 in)**

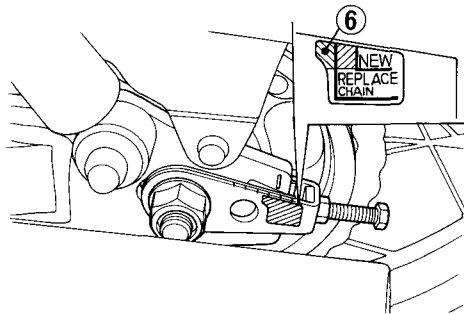

(6) Red zone

### Lubrication and cleaning:

Lubricate every 1,000 km (600 miles) or sooner if chain appears dry.

The O-rings in this chain can be damaged by steam cleaning, high pressure washers, and certain solvents. Clean the chain with high flash-point solvent, such as parafin. Wipe dry and lubricate only with SAE 80 or 90 gear oil. Commercial chain lubricants may contain solvents which could damage the rubber O-rings.

Replacement chain:

DID520VC-6 or RK520M0

### **CAUTION:**

\* **The drive chain on this motorcycle is equipped with small O-rings between the link plates. These O-rings retain grease inside the chain to improve its service life. However, special precautions must be taken when adjusting, lubricating, washing, and replacing the chain.**

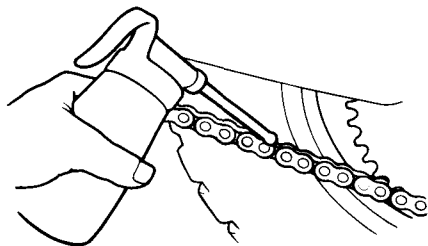

## FRONT AND REAR SUSPENSION INSPECTION

(Refer to the maintenance precautions on page 44).

1. Check the front fork assembly by locking the front brake and pumping the fork up and down vigorously. Suspension action should be smooth and there must be no oil leakage.
2. Rear fork bushing—this can be checked by pushing hard against the side of the rear wheel while the motorcycle is on the center stand and feeling for looseness of the fork bushings.
3. Carefully inspect all front and rear suspension fasteners for tightness.

## SIDE STAND

(Refer to the maintenance precautions on page 44).

Check the rubber pad for deterioration and wear. Replace if wear extends to the wear mark (See (1) in the picture). Check the side stand assembly for freedom of movement. If parts must be replaced, please contact an authorized HONDA dealer.

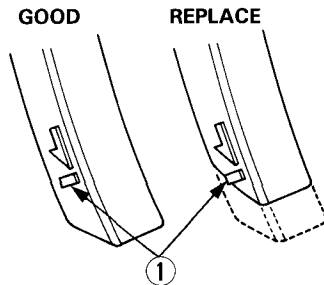

(1) Wear mark

## WHEEL REMOVAL

(Refer to the maintenance precautions on page 44).

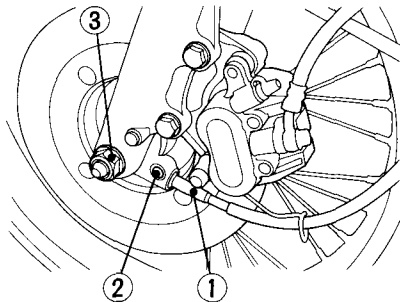

- (1) Speedometer cable (3) Axle nut  
(2) Cable set screw

## Front Wheel Removal

1. Raise the front wheel off the ground by using a chain block.
2. Disconnect the speedometer cable (1) by removing the speedometer cable set screw (2).
3. Remove the axle nut (3). Pull out the front axle (4). Remove the front wheel.

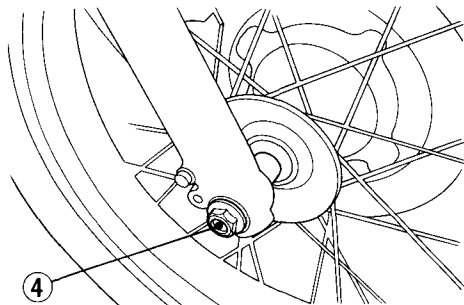

- (4) Axle

## NOTE:

- \* Do not depress the brake lever when the wheel is off the motorcycle. The caliper pistons will be forced out of the cylinders with subsequent loss of brake fluid. If this occurs, servicing of the brake system will be necessary. See your authorized Honda dealer for this service.

## Installation Notes:

To install the front wheel assembly, install the brake disc between the brake pads taking care not to damage the brake pads and insert the axle through the right fork leg and wheel hub, and screw it into the left fork leg.

Make sure that the tang (5) on the fork leg is located in the slot (6) in the speedometer gearbox (7). Tighten the axle nut to specified torque.

Axle nut torque:

60 N·m (6.0 kg-m, 43 ft-lb)

After installing the wheel, apply the brake several times, and check for free wheel rotation when released.

## ▲ WARNING

- \* **If a torque wrench was not used for installation, see your authorized Honda dealer as soon as possible to verify proper assembly. Improper assembly may lead to loss of breaking capacity.**

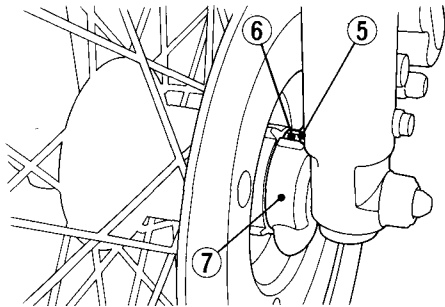

(5) Tang  
(6) Slot

(7) Speedometer  
gearbox

## Rear Wheel Removal

(Refer to the maintenance precautions on page 44).

1. Place the motorcycle on its center stand.
2. Remove the rear brake adjusting nut (1). Disconnect the brake rod (2) from the brake arm (3).
3. Disconnect the brake stopper arm (4) from

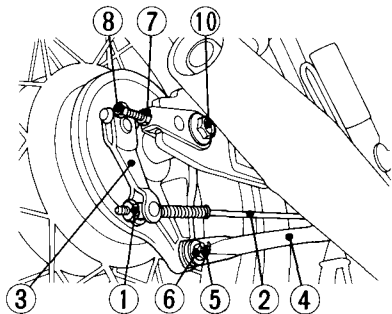

- |                   |                     |
|-------------------|---------------------|
| (1) Adjusting nut | (5) Cotter pin      |
| (2) Brake rod     | (6) Stopper arm nut |
| (3) Brake arm     | (10) Axle           |
| (4) Stopper arm   |                     |

60

the brake panel by removing the cotter pin (5), stopper arm nut (6), washer and rubber grommet.

4. Loosen the drive chain lock nuts (7) and adjusting bolts (8).
5. Remove the axle nut (9) and pull out the rear axle (10). Push the wheel forward and remove the drive chain from the rear sprocket.
6. Pull out the wheel from the swingarm.

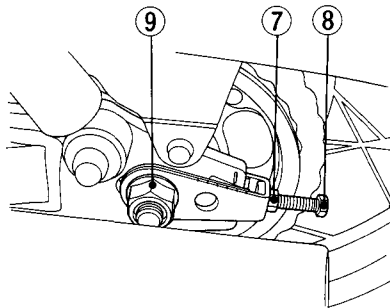

- |                    |              |
|--------------------|--------------|
| (7) Lock nut       | (9) Axle nut |
| (8) Adjusting bolt |              |

### Installation Note:

- Reverse the removal procedure.
- Tighten the axle nut and stopper arm nut to specified torque.

Axle nut torque:

90 N·m (9.0 kg·m, 65 ft·lb)

- Brake stopper arm nut torque:  
22 N·m (2.2 kg·m, 16 ft·lb)
- Adjust the brake (page 14) and drive chain (page 54).
- After installing the wheel, apply the brakes several times, and check for free wheel rotation when released.

### **⚠ WARNING**

- \* **If a torque wrench was not used for installation, see your authorized Honda dealer as soon as possible to verify proper assembly. Improper assembly may lead to loss of braking capacity.**

### **CAUTION:**

- \* **Used cotter pins may not effectively secure fasteners. Always replace used cotter pins with new ones.**

## BRAKE PAD WEAR

(Refer to the maintenance precautions on page 44).

The front brake pad wear will depend upon the severity of usage, type of riding, and condition of the roads. The pads will wear faster on dirty and wet roads. Inspect the pads (1) visually from under the caliper (2) during all regular service

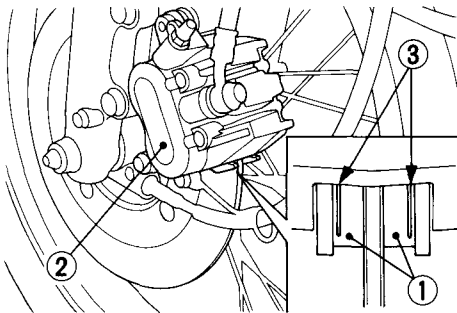

(1) Brake pads  
(2) Caliper

(3) Wear limit

intervals to determine the pad wear. If either pad wears to the wear limit (3), both pads must be replaced as a set.

### Other Checks:

Make sure there are no fluid leaks. Check for deterioration or cracks in the hose and fittings.

### NOTE:

\* Use only genuine Honda replacement friction pads offered by authorized Honda dealers. When brake service is necessary consult your Honda dealer.

## BRAKE SHOE WEAR

(Refer to the maintenance precautions on page 44).

The rear brake is equipped with brake wear indicator.

When the brake is applied, an arrow (1) attached to the brake arm (2) moves toward a reference mark (3) on the brake panel (4).

If the arrow aligns with the reference mark on full application of the brake, the brake shoes must be replaced.

### NOTE:

\* When the brake service is necessary, see your authorized Honda dealer. Use only genuine Honda parts or its equivalent.

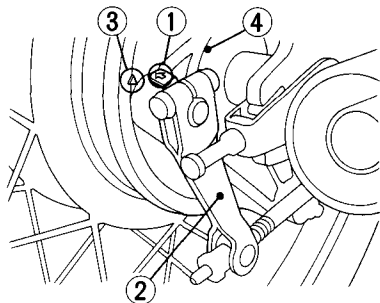

(REAR)

(1) Arrow

(2) Brake arm

(3) Reference mark

(4) Brake panel

## BATTERY

(Refer to the maintenance precautions on page 44).

If the motorcycle is operated with insufficient battery electrolyte, sulfation and battery plate damage will occur.

If rapid loss of electrolyte is experienced, or if your battery seems to be weak, causing slow starting or other electrical problems, see your authorized Honda dealer.

### Battery electrolyte:

The battery is behind the right side cover. Remove the right side cover. Check the electrolyte level with the motorcycle in an upright position on level ground. The electrolyte level must be maintained between the UPPER (1) and LOWER (2) LEVEL marks on the side of the battery. If the electrolyte level is low, disconnect the negative (-) terminal lead (3) from the battery first, then disconnect the positive (4) terminal lead. Disconnect the battery breather tube (5). Remove the rubber band (6). Pull out the battery. Remove the battery filler caps (7). Carefully add distilled water to the UPPER LEVEL mark, using a small syringe or plastic funnel.

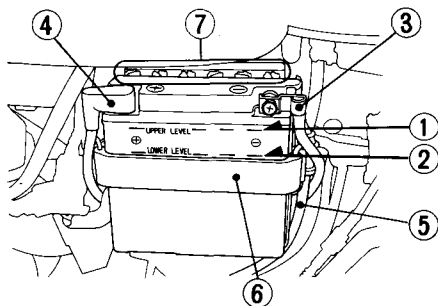

- |                       |                   |
|-----------------------|-------------------|
| (1) UPPER LEVEL       | (5) Breather tube |
| (2) LOWER LEVEL       | (6) Rubber band   |
| (3) Negative terminal | (7) Filler caps   |
| (4) Positive terminal |                   |

**CAUTION:**

- \* When checking the battery electrolyte level, or adding distilled water, make sure the breather tube is connected to the battery breather outlet.
- \* Use only distilled water in the battery. Tap water will shorten the service life of the battery.
- \* Filling the battery above the UPPER LEVEL line may cause the electrolyte to overflow, resulting in corrosion to engine or nearby parts. Immediately wash off any spilled electrolyte.
- \* The battery breather tube must be routed as shown on the label. Do not bend or twist the breather tube. A bent or kinked breather tube may pressurize the battery and damage its case.

**⚠ WARNING**

- \* The battery gives off explosive gases; keep sparks, flames, and cigarettes away. Provide adequate ventilation when charging or using the battery in an enclosed space.
- \* The battery contains sulfuric acid (electrolyte). Contact with skin or eyes may cause severe burns. Wear protective clothing and a face shield.
  - If electrolyte gets on your skin, flush with water.
  - If electrolyte gets in your eyes, flush with water for at least 15 minutes and call a physician immediately.
- \* Electrolyte is poisonous.
  - If swallowed, drink large quantities of water or milk and follow with milk of magnesia or vegetable oil and call a physician.
- \* **KEEP OUT OF REACH OF CHILDREN.**

## FUSE REPLACEMENT

(Refer to maintenance precautions on page 44).  
The main fuse (1), located near the battery in the fuse box, is 15 A.

The other fuses (2) are also located in the same fuse box.

The specified rating of these fuses is 7 A.

When frequent fuse failure occurs, it usually in-

dicates a short circuit or an overload in the electrical system. See your authorized Honda dealer for repair.

### CAUTION:

**\* Turn the ignition switch OFF before checking or replacing fuses to prevent accidental short-circuiting.**

To replace the main fuse (1) or fuses (2) in the fuse box, remove the right side cover. Remove the fuse cover (3).

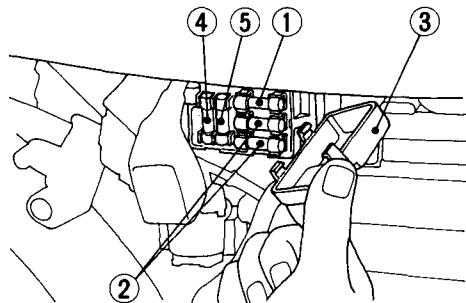

- |                |                     |
|----------------|---------------------|
| (1) Main fuse  | (4) Spare main fuse |
| (2) Fuses      | (5) Spare fuse      |
| (3) Fuse cover |                     |

Pull the old fuse out of the clips; or slide it lengthwise until one end comes out, then lift it out with your fingers. Push a new fuse into the clips and install the fuse cover.

**⚠ WARNING**

- \* **Never use a fuse with a different rating from that specified. Serious damage to the electrical system or a fire may result, causing a dangerous loss of lights or engine power.**
- \* **Do not pry the clips open to get a fuse out; you could bend them and cause poor contact with the new fuse. A loose fuse could cause damage to the electrical system and even start a fire.**

**REMOVAL**

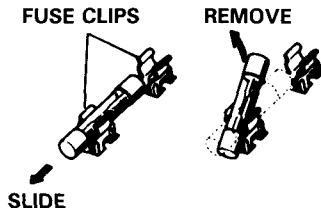

**INSTALLATION**

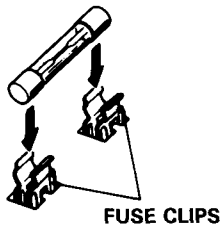

## CLEANING

Clean your motorcycle regularly to protect the surface finishes and inspect for damage, wear, and oil, or hydraulic fluid seepage.

### CAUTION:

- \* **Avoid spraying high pressure water (typical in coil-operated car washes) at the following areas:**

**Wheel Hubs**

**Carburetors**

**Instruments**

**Under Seat**

**Drive Chain**

**Ignition Switch**

**Brake Master**

**Cylinder**

**Muffler Outlets**

**Under Fuel Tank**

**Handlebar Switches**

1. After cleaning, rinse the motorcycle thoroughly with plenty of clean water. Strong detergent residue can corrode alloy parts.
2. Dry the motorcycle, start the engine, and let it run for several minutes.

### ▲ WARNING

- \* **Braking efficiency may be temporarily impaired immediately after washing the motorcycle. Anticipate longer stopping distance to avoid a possible accident.**
3. Test the brakes before riding the motorcycle. Several applications may be necessary to restore normal braking performance.
  4. Lubricate the drive chain immediately after washing the motorcycle.

## STORAGE GUIDE

### STORAGE

Extended storage, such as for winter, requires that you take certain steps to reduce the effects of deterioration from non-use of the motorcycle. In addition, necessary repairs should be made **BEFORE** storing the motorcycle; otherwise, these repairs may be forgotten by the time the motorcycle is removed from storage.

1. Change the engine oil.
2. Lubricate the drive chain.
3. Drain the fuel tank and carburetors. Spray the inside of the tank with an aerosol rust-inhibiting oil.  
Reinstall the fuel cap on the tank.

#### NOTE:

- \* If storage will last more than one month, carburetor draining is very important, to assure proper performance after storage.

#### WARNING

- \* **Petrol is flammable and is explosive under certain conditions. Do not smoke or allow flames or sparks near the equipment while draining fuel.**
4. Remove the spark plugs and pour a tablespoon (15–20 cm<sup>3</sup>) of clean engine oil into each cylinder. Crank the engine several times to distribute the oil, then reinstall the spark plugs.

#### NOTE:

- \* When turning the engine over, the Engine Stop Switch should be OFF and each spark plug placed in its cable cap and grounded to prevent damage to the ignition system.

5. Remove the battery. Store in an area protected from freezing temperatures and direct sunlight.  
Check the electrolyte level and slow charge the battery once a month.
6. Wash and dry the motorcycle. Wax all painted surfaces. Coat chrome with rust-inhibiting oil.
7. Inflate the tyres to their recommended pressures. Place the motorcycle on blocks to raise both tyres off the ground.
8. Cover the motorcycle (don't use plastic or other coated materials) and store in an unheated area, free of dampness with a minimum of daily temperature variation. Do not store the motorcycle in direct sunlight.

## **REMOVAL FROM STORAGE**

1. Uncover and clean the motorcycle. Change the engine oil if more than 4 months have passed since the start of storage.
2. Check the battery electrolyte level and charge the battery as required. Install the battery.
3. Drain any excess aerosol rust-inhibiting oil from the fuel tank. Fill the fuel tank with fresh petrol.
4. Perform all Pre-ride Inspection checks (page 31). Test ride the motorcycle at low speeds in a safe riding area away from traffic.

# **SPECIFICATIONS**

## **DIMENSIONS**

Overall length	2,000 mm (78.7 in)
Overall width	765 mm (30.1 in)
Overall height	1,060 mm (41.7 in)
Wheelbase	1,325 mm (52.2 in)
Ground clearance	145 mm (5.7 in)

## **WEIGHT**

Dry weight	145 kg (319 lbs)
------------	------------------

## **CAPACITIES**

Engine oil	1.3 ℓ (1.4 US qt, 1.1 Imp qt) After draining
Fuel tank	10.0 ℓ (2.6 US gal, 2.2 Imp gal)
Fuel reserve tank	1.8 ℓ (0.5 US gal, 0.4 Imp gal)
Passenger capacity	Operator and one passenger
Maximum weight capacity	170 kg (375 lbs)

## ENGINE

Bore and stroke	53.0 x 53.0 mm (2.09 x 2.09 in)
Compression ratio	9.2 : 1
Displacement	233 cm <sup>3</sup> (14.2 cu.in)
Spark plug	
Standard:	CR6HSA (NGK) or U20FSR-U (ND)
For cold climate: (Below 5°C, 41°F)	CR5HSA (NGK) or U16FSR-U (ND)
For extended high speed riding:	CR7HSA (NGK) or U22FSR-U (ND)
Spark plug gap	0.6—0.7 mm (0.024—0.028 in)
Valve clearance:	
Intake	0.08 mm (0.003 in)
Exhaust	0.08 mm (0.003 in)
Idle speed	1,300 ± 100 min <sup>-1</sup> (rpm)

## CHASSIS AND SUSPENSION

Caster	27°30'
Trail	92 mm (3.6 in)
Tyre size, front	3.00-17-4PR
Tyre size, rear	3.25-17-6PR

## POWER TRANSMISSION

Primary reduction	3.6315 : 1
Final reduction	2.2857 : 1
Gear ratio, 1st	2.8461 : 1
2nd	1.7777 : 1
3rd	1.3333 : 1
4th	1.0833 : 1
5th	0.9130 : 1

## ELECTRICAL

Battery	12V-9 AH
Alternator	A.C. Generator 0.33 kW/5,000 min <sup>-1</sup> (rpm)

## LIGHTS

Headlight (High/Low)	12V-45/40W
Position light	12V-4W
Tail/stoplight	12V-5/21 W
Turn signal light	12V-21 W x 4
Instrument light	12V-3.4 W
Neutral indicator	12V-1.7 W
Turn signal indicator	12V-1.7 W
High beam indicator	12V-1.7 W

## FUSE

7 amp x 2, 15 amp (Main fuse)

## **NOISE CONTROL SYSTEM (AUSTRALIA ONLY)**

### **TAMPERING WITH NOISE CONTROL SYSTEM PROHIBITED**

Owners are warned that the law may prohibit:

- (a) The removal or rendering inoperative by any person other than for purposes of maintenance, repair or replacement, of any device or element of design incorporated into any new vehicle for the purpose of noise control prior to its sale or delivery to the ultimate purchaser or while it is in use; and
- (b) the use of the vehicle after such device or element of design has been removed or rendered inoperative by any person.

## MEMO

## MEMO

# CD250U E type

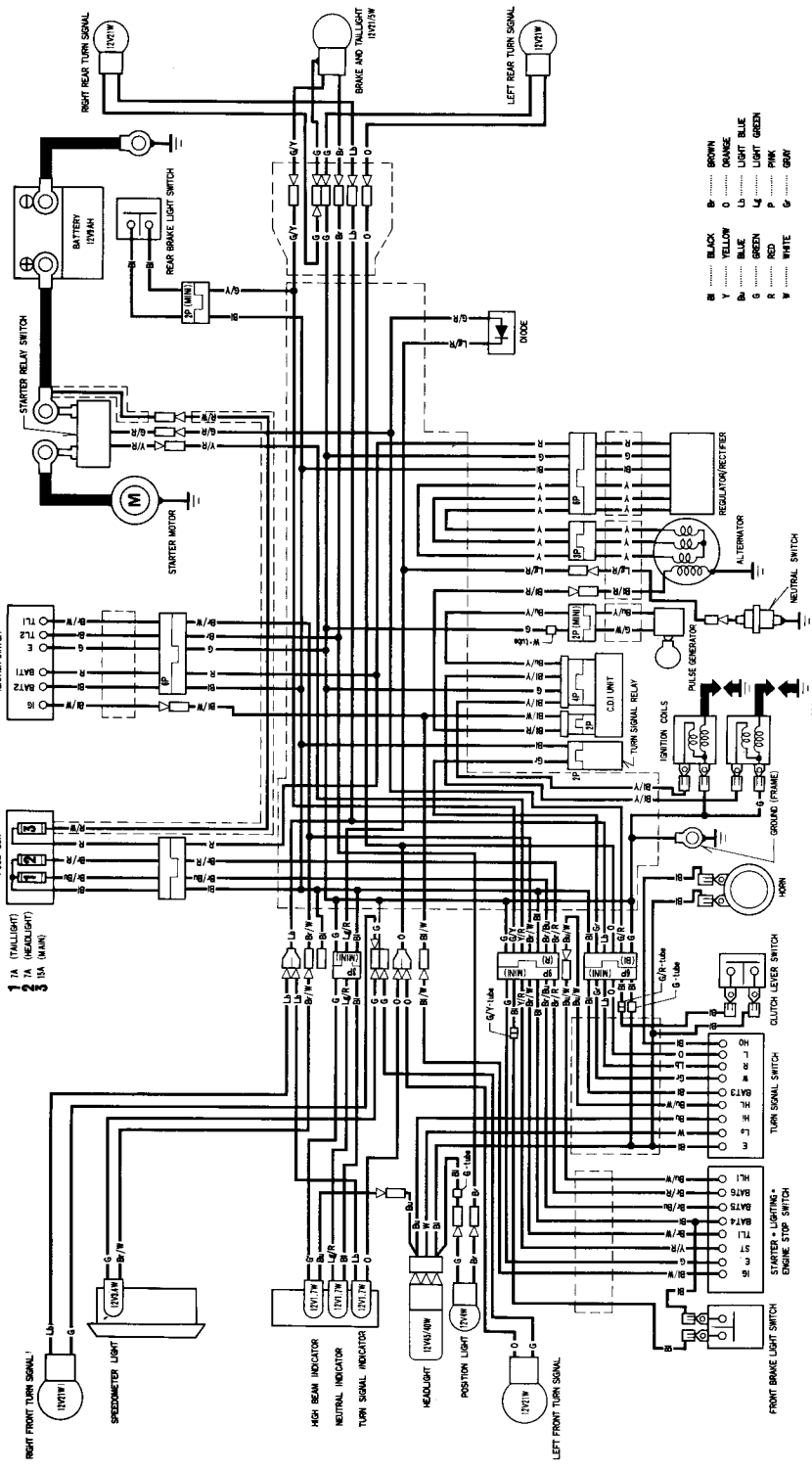

- B ..... BLACK
- Y ..... YELLOW
- G ..... GREEN
- R ..... RED
- W ..... WHITE
- Br ..... BROWN
- O ..... ORANGE
- Bl ..... BLUE
- L ..... LIGHT GREEN
- Li ..... LIGHT BLUE
- P ..... PINK
- G ..... GRAY

- 1 1A (TALLIGHT)
- 2 2A (HEADLIGHT)
- 3 5A (MAIN)

SWITCH CONTINUITY

TURN SIGNAL SWITCH	W	R	L			
	R	N	L			
HORN SWITCH	HO	BAT3				
	FREE	PUSH				
DIMMER SWITCH	NL	H	Ls			
	HL	(H)	(L)			
PASSING SWITCH	N	BAT3				
	FREE	PUSH				
LUSHER SWITCH	BAT5	TL	BAT5	NL		
	OFF	P	H			
STARTER SWITCH	BAT4	ST				
	FREE	PUSH				
ENGINE STOP SWITCH	ION	E				
	OFF	RUN				
IGNITION SWITCH	IS	E	BAT1	BAT2	TL	TL2
	ON	OFF				

E type only

0030Z — KW4 — 6000

