

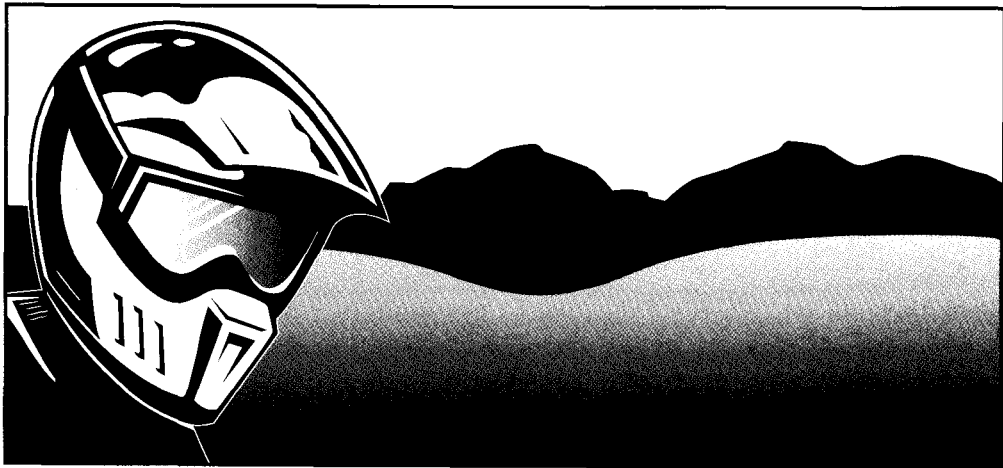

Manual del Propietario
Owner's Manual



CRF230F

Honda CRF230F

OWNER'S MANUAL

Moto Honda da Amazônia Ltda.

IMPORTANT INFORMATION

- **OPERATOR ONLY. NO PASSENGER**

This motorcycle is designed and constructed as an operator-only model. The seating configuration does not safely permit the carrying of a passenger. Do not exceed the maximum weight capacity.

- **FOR OFF-ROAD USE ONLY**

This motorcycle is designed and manufactured for off-road use only.

- **READ THIS OWNER'S MANUAL CAREFULLY**

Pay special attention to the safety messages that appear throughout the manual. These messages are fully explained in the "A Few Words About Safety" section which appears before the Contents page.

This manual should be considered a permanent part of the motorcycle and should remain with the motorcycle when resold.

Honda CRF230F

OWNER'S MANUAL

"U" TYPE

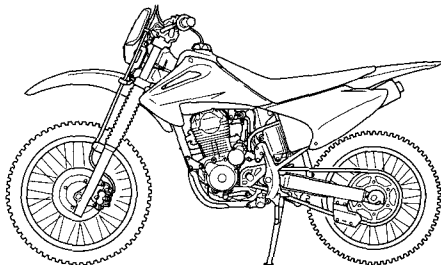
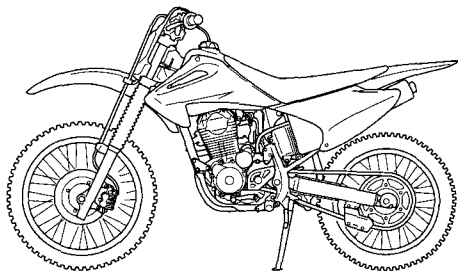

All information in this publication is based on the latest production information available at the time of approval for printing. Moto Honda da Amazônia Ltda. reserves the right to make changes at any time without notice and without incurring any obligation. No part of this publication may be reproduced without written permission.

WELCOME

Your new motorcycle presents you with an invitation to adventure and a challenge to master the machine. Your safety depends not only on your own alertness and familiarity with the motorcycle, but also the motorcycle's mechanical condition. A pre-ride inspection before every outing and regular maintenance are essential.

To help meet the challenges safely and enjoy the adventure fully, become thoroughly familiar with this Owner's Manual **BEFORE YOU RIDE THE MOTORCYCLE**.

As you read this manual, you will find information that is preceded by a **NOTICE** symbol. This information is intended to help you avoid damage to your motorcycle, other property, or the environment.

When service is required, remember that your Honda dealer knows your motorcycle best. If you have the required mechanical "know-how" and tools, your dealer can supply you with an official Honda Service Manual to help you perform many maintenance and repair tasks.

Pleasant riding, and thank you for choosing a Honda!

- Following codes in this manual indicate each country.

U	Australia (with headlight)
---	----------------------------

- The specifications may vary with each locale.

A FEW WORDS ABOUT SAFETY

Your safety, and the safety of others, is very important. And operating this motorcycle safely is an important responsibility.

To help you make informed decisions about safety, we have provided operating procedures and other information on labels and in this manual. This information alerts you to potential hazards that could hurt you or others.

Of course, it is not practical or possible to warn you about all hazards associated with operating or maintaining a motorcycle. You must use your own good judgment.

You will find important safety information in a variety of forms, including:

- **Safety Labels** — on the motorcycle.
- **Safety Messages** — preceded by a safety alert symbol  and one of three signal words: **DANGER, WARNING, or CAUTION.**

These signal words mean:

▲ DANGER

You **WILL** be **KILLED** or **SERIOUSLY HURT** if you don't follow instructions.

▲ WARNING

You **CAN** be **KILLED** or **SERIOUSLY HURT** if you don't follow instructions.

▲ CAUTION

You **CAN** be **HURT** if you don't follow instructions.

- **Safety Headings** — such as Important Safety Reminders or Important Safety Precautions.
- **Safety Section** — such as Motorcycle Safety.
- **Instructions** — how to use this motorcycle correctly and safely.

This entire manual is filled with important safety information — please read it carefully.

OPERATION

page

- 1 MOTORCYCLE SAFETY
- 1 Important Safety Information
- 3 Protective Apparel
- 5 Load Limits and Guidelines

9 PARTS LOCATION

15 MAJOR COMPONENTS (Information you need to operate this motorcycle)

- 15 Brakes
- 19 Clutch
- 21 Fuel
- 25 Engine Oil
- 26 Tyres

page

- 31 ESSENTIAL INDIVIDUAL
COMPONENTS
- 31 Ignition Switch
- 32 Starter Button
- 32 Engine Stop Button

page

33	FEATURES (Not required for operation)
33	Left Side Cover
34	Right Side Cover

page

35	OPERATION
35	Pre-ride Inspection
37	Starting the Engine
40	Running-in
41	Riding
43	Braking
44	Parking
44	Anti-theft Tips

MAINTENANCE

page

45	MAINTENANCE
45	The Importance of Maintenance
46	Maintenance Safety
47	Safety Precautions
48	Maintenance Schedule
51	Competition Inspection
53	Tool Kit
54	Serial Numbers
55	Colour Label
56	Air Cleaner
59	Crankcase Breather
60	Engine Oil
63	Spark Plug
65	Idle Speed
66	Throttle Operation
68	Spark Arrester
69	Drive Chain
75	Wheel Rims and Spokes
76	Wheel Removal
80	Brake Pad Wear
81	Brake Shoe Wear
82	Battery
84	Fuse Replacement
86	Front Suspension
87	Rear Suspension

page

88	Side Stand
89	Bulb Replacement
91	CLEANING
94	STORAGE GUIDE
94	Storage
96	Removal from Storage
97	SPECIFICATIONS

MOTORCYCLE SAFETY

IMPORTANT SAFETY INFORMATION

Your motorcycle can provide many years of service and pleasure — if you take responsibility for your own safety and understand the challenges you can meet while riding.

There is much that you can do to protect yourself when you ride. You'll find many helpful recommendations throughout this manual. Following are a few that we consider most important.

Always Wear a Helmet

It's a proven fact: helmets significantly reduce the number and severity of head injuries. So always wear an approved motorcycle helmet. We also recommend that you wear eye protection, sturdy boots, gloves and other protective gear (page 3).

Never Carry a Passenger

Your motorcycle is designed for one person only. There are no handholds, footrests, or seat for a second person — so never carry a passenger. A passenger could interfere with your ability to move around to maintain your balance and control of the motorcycle.

Ride Off-Road Only

Your motorcycle is designed and manufactured for off-road use only. The tyres are not made for pavement, and the motorcycle does not have turn signals and other features required for use on public roads. If you need to cross a paved or public road, get off and walk your motorcycle across.

Take Time to Learn and Practice

Developing off-road riding skills is a gradual, step-by-step process. Start by practicing at low speeds in a safe area and slowly build your skills. Personal instruction from an experienced rider can also be valuable.

If you need assistance, ask your dealer about riding groups in your area.

Be Alert for Off-Road Hazards

The terrain can present a variety of challenges when you ride off-road. Continually “read” the terrain for unexpected turns, drop-offs, rocks, ruts, and other hazards. Always keep your speed low enough to allow time to see and react to hazards.

Ride Within Your Limits

Pushing the limits is another major cause of motorcycle accidents. Never ride beyond your personal abilities or faster than conditions warrant. Remember that alcohol, drugs, fatigue and inattention can significantly reduce your ability to make good judgements and ride safely.

Keep Your Bike in Safe Condition

It's important to keep your motorcycle properly maintained and in safe riding condition. Having a breakdown can be difficult, especially if you are stranded off-road far from your base. To help avoid problems, inspect your motorcycle before every ride and perform all recommended maintenance.

Don't Drink and Ride

Alcohol and riding don't mix. Even one drink can reduce your ability to respond to changing conditions, and your reaction time gets worse with every additional drink. So don't drink and ride, and don't let your friends drink and ride either.

PROTECTIVE APPAREL

For your safety, we strongly recommend that you always wear an approved motorcycle helmet, eye protection, boots, gloves, long pants, and a long-sleeved jersey, shirt or jacket whenever you ride. Although complete protection is not possible, wearing proper gear can reduce the chance of injury when you ride. Following are suggestions to help you choose proper gear.

▲ WARNING

Not wearing a helmet increases the chance of serious injury or death in a crash.

Be sure you always wear a helmet, eye protection and other protective apparel when you ride.

Helmets and Eye Protection

Your helmet is your most important piece of riding gear because it offers the best protection against head injuries. A helmet should fit your head comfortably and have a chin strap that can be tightened securely.

An open-face helmet offers some protection, but a full-face helmet offers more. Always wear a face shield or goggles to protect your eyes and help your vision.

Additional Riding Gear

In addition to a helmet and eye protection, we also recommend:

- Sturdy off-road motorcycle boots to help protect your feet, ankles, and lower legs.
- Off-road motorcycle gloves to help protect your hands.
- Riding pants with knee and hip pads, a riding jersey with padded elbows, and a chest/shoulder protector.

LOAD LIMITS AND GUIDELINES

Your Honda was designed as a rider-only motorcycle. It was not designed to carry a passenger or cargo. A passenger or cargo could interfere with your ability to move around to maintain your balance and control of the motorcycle.

In addition, exceeding the weight limits or carrying an unbalanced load can seriously affect your motorcycle's handling, braking, and stability. Adding accessories or making modifications that change this motorcycle's design and performance can also make it unsafe. Also, the weight of any accessories will reduce the maximum load the motorcycle can carry.

The following pages give more specific information on loading, accessories and modifications.

Loading

How much weight you put on your motorcycle, and how you load it, are important to your safety. If you decide to carry cargo, you should be aware of the following information.

▲ WARNING

Overloading or carrying a passenger can cause a crash and you can be seriously hurt or killed.

Follow all load limits and other loading guidelines in this manual.

Load Limits

Following are the load limits for your motorcycle:

Maximum weight capacity:

100 kg (220 lbs)

Includes the weight of the rider and any accessories

The weight of added accessories will reduce the maximum cargo weight you can carry.

Loading Guidelines

As discussed on page 5, we recommend that you do not carry any cargo on this motorcycle. However, if you decide to carry cargo, ride at reduced speeds and follow these common-sense guidelines:

- Keep cargo small and light. Make sure it cannot easily be caught on brush or other objects, and that it does not interfere with your ability to shift position to maintain balance and stability.

- Place weight as close to the center of the motorcycle as possible.
- Do not attach large or heavy items (such as a sleeping bag or tent) to the handlebar, fork, or front fender.
- Make sure that all cargo is tied down securely.
- Never exceed the maximum weight limit.
- Check that both tyres are inflated properly.

Accessories and Modifications

Modifying your motorcycle or using non-Honda accessories can make your motorcycle unsafe. Before you consider making any modifications or adding an accessory, be sure to read the following information.

▲ WARNING

Improper accessories or modifications can cause a crash in which you can be seriously hurt or killed.

Follow all instructions in this owner's manual regarding accessories and modifications.

Accessories

We strongly recommend that you use only genuine Honda accessories that have been specifically designed and tested for your motorcycle. Because Honda cannot test all other accessories, you must be personally responsible for proper selection, installation and use of non-Honda accessories. Check with your dealer for assistance and always follow these guidelines:

- Make sure the accessory does not reduce ground clearance and banking angle, limit suspension travel or steering travel, alter your riding position or interfere with operating any controls.

Modifications

We strongly advise you not to remove any original equipment or modify your motorcycle in any way that would change its design or operation. Such changes could seriously impair your motorcycle's handling, stability and braking, making it unsafe to ride.

Removing or modifying your exhaust system (such as the spark arresters or mufflers) or other equipment can also make your motorcycle illegal.

PARTS LOCATION

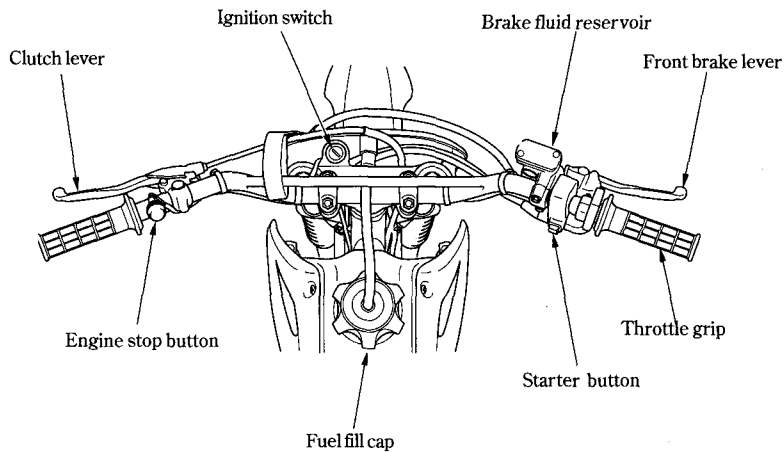

PARTS LOCATION ("U" TYPE)

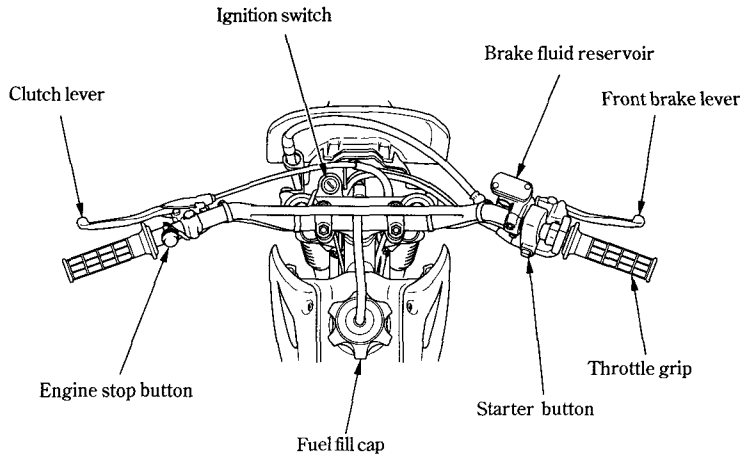

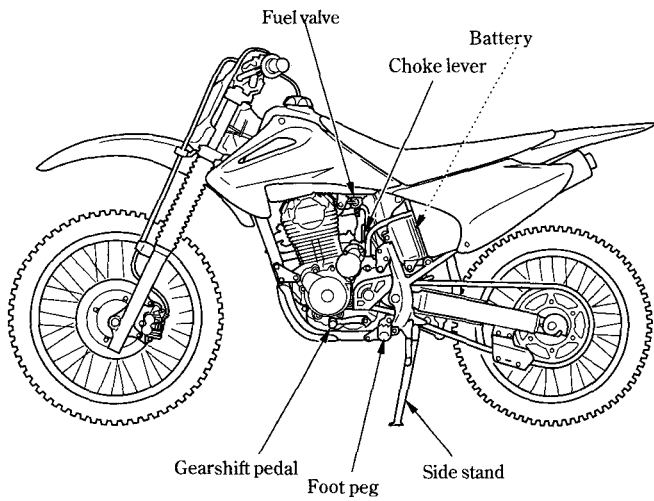

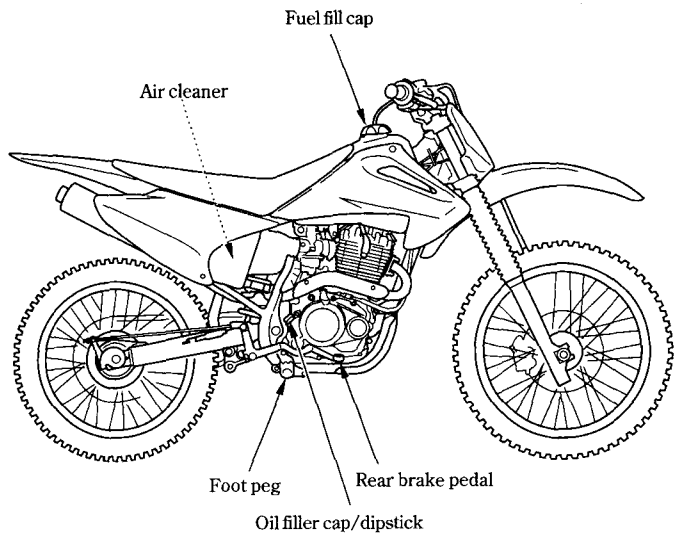

(“U” TYPE)

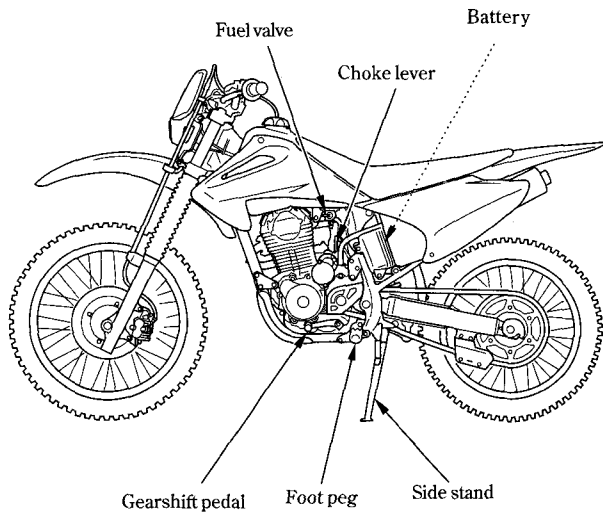

(“U” TYPE)

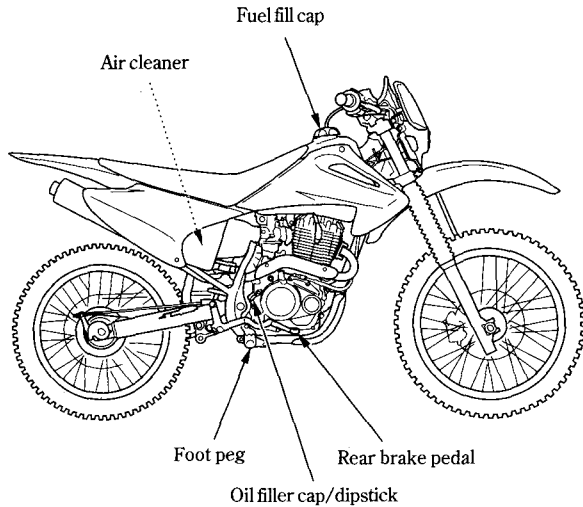

MAJOR COMPONENTS

(Information you need to operate this motorcycle)

BRAKES

Front Brake

This motorcycle has a hydraulic front disc brake. As the brake pads wear, brake fluid level drops. There are no adjustments to perform, but fluid level and pad wear must be inspected periodically. The system must be inspected frequently to ensure there are no fluid leaks. If the control lever free travel becomes excessive and the brake pads are not worn beyond the recommended limit (page 77), there is probably air in the brake system and it must be bled. See your Honda dealer for this service.

Brake Fluid Level:

With the motorcycle in an upright position, check the fluid level. It should be above the LOWER level mark (1). If the level is at or below the LOWER level mark (1), check the brake pads for wear (page 80).

Worn pads should be replaced. If the pads are not worn, have your brake system inspected for leaks.

The recommended brake fluid is Honda DOT 4 brake fluid from a sealed container, or an equivalent.

Front

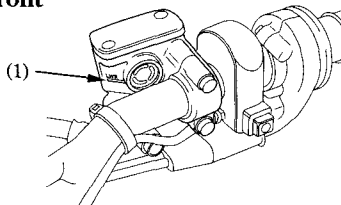

(1) LOWER level mark

Front Brake Lever:

Never use adjusters other than those designed for this motorcycle. Install a new adjuster from the lever side with the lock nut under the head of the adjuster.

1. Pull back the rubber dust cover (2).
2. Loosen the lock nut (3).
3. To position the brake lever farther away from the handgrip, turn the adjuster (4) clockwise.

To position the brake lever closer to the handgrip, turn the adjuster counterclockwise.

4. Tighten the lock nut. Return the dust cover to its normal position.
5. Apply the brake, release it, then spin the wheel and check that it rotates freely.
6. Check freeplay by pulling in slowly on the front brake lever until the brake starts to engage.

Freeplay:

10 - 20 mm (0.4 - 0.8 in)

If brake lever freeplay is not within this range, see your Honda dealer.

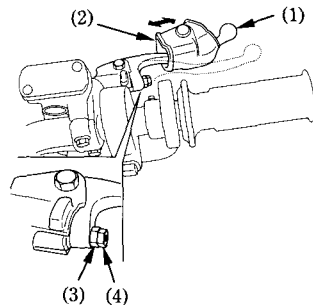

- | | |
|-----------------------|--------------|
| (1) Front brake lever | (3) Lock nut |
| (2) Dust cover | (4) Adjuster |

Other Checks:

Make sure there are no fluid leaks. Check for deterioration or cracks in the hoses and fittings.

Rear Brake

Adjustment:

1. Place the motorcycle on its side stand.
2. The stopper bolt (1) is provided to allow adjustment of the pedal height.

To adjust the pedal height, loosen the lock nut (2) and turn the stopper bolt.

Tighten the lock nut.

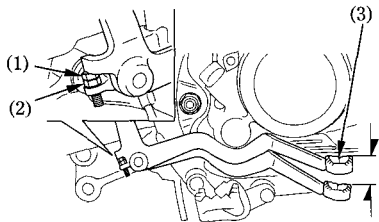

- (1) Stopper bolt
(2) Lock nut

(3) Rear brake pedal

3. Measure the distance the rear brake pedal (3) moves before the brake starts to take hold.

Free play should be:

20 – 30 mm (0.8 – 1.2 in)

4. If adjustment is necessary, turn the rear brake adjusting nut (4).

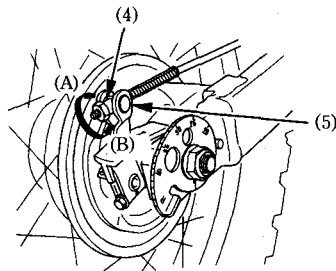

- (4) Adjusting nut
(5) Arm pin

(A) Decrease free play
(B) Increase free play

Make sure the cut-out on the adjusting nut is seated on the brake arm pin (5) after making final free play adjustment.

If proper adjustment cannot be obtained by this method, see your Honda dealer.

5. Apply the brake several times and check for free wheel rotation after the brake pedal is released.

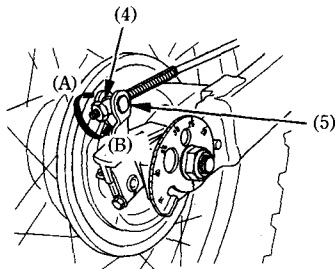

(4) Adjusting nut

(5) Arm pin

(A) Decrease free play

(B) Increase free play

Other Checks:

Make sure the brake rod, brake arm, spring and fasteners are in good condition.