

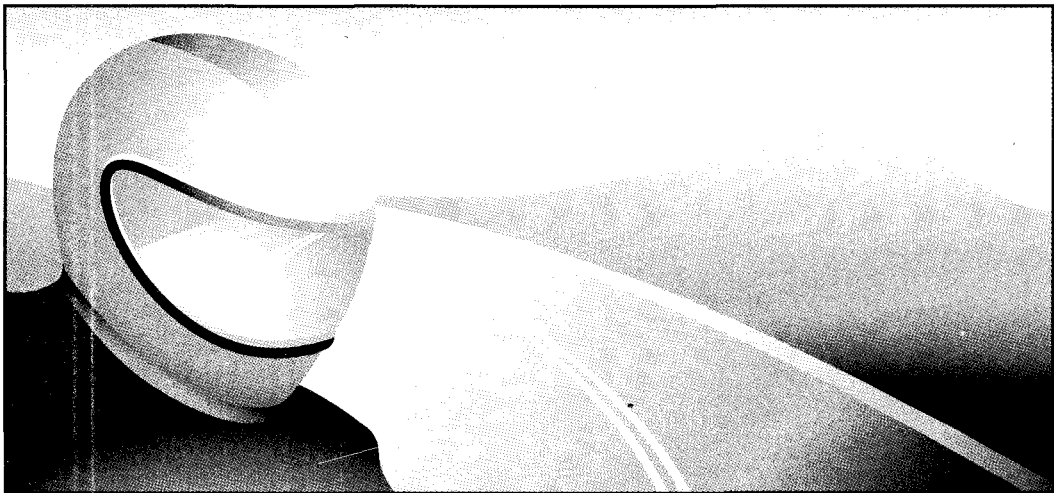

**OWNER'S MANUAL
USO E MANUTENZIONE
MANUAL DEL PROPIETARIO**



**FJS600 D/A
SILVER WING**

**Honda FJS600 D/A
SILVER WING**

OWNER'S MANUAL

USO E MANUTENZIONE

MANUAL DEL PROPIETARIO

IMPORTANT INFORMATION

- **OPERATOR AND PASSENGER**

This scooter is designed to carry the operator and one passenger. Never exceed the maximum weight capacity as shown on the accessories and loading label.

- **ON-ROAD USE**

This scooter is designed to be used only on the road.

- **READ THIS OWNER'S MANUAL CAREFULLY**

Pay special attention to the safety messages that appear throughout the manual. These messages are fully explained in the "A Few Words About Safety" section which appears before the Contents page.

This manual should be considered a permanent part of the scooter and should remain with the scooter when resold.

**Honda FJS600 D/A
SILVER WING
OWNER'S MANUAL**

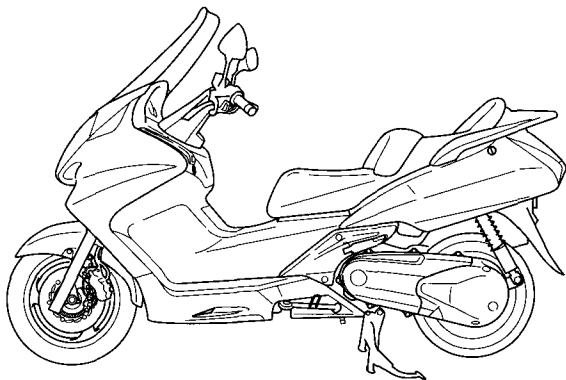

All information in this publication is based on the latest production information available at the time of approval for printing. Honda Motor Co.,Ltd. reserves the right to make changes at any time without notice and without incurring any obligation.

No part of this publication may be reproduced without written permission.

WELCOME

The scooter presents you a challenge to master the machine, a challenge to adventure. You ride through the wind, linked to the road by a vehicle that responds to your commands as no other does. Unlike an automobile, there is no metal cage around you. Like an airplane, a pre-ride inspection and regular maintenance are essential to your safety. Your reward is freedom.

To meet the challenges safely, and to enjoy the adventure fully, you should become thoroughly familiar with this owner's manual **BEFORE YOU RIDE THE SCOOTER**.

As you read this manual, you will find information that is preceded by a **NOTICE** symbol. This information is intended to help you avoid damage to your scooter, other property, or the environment.

When service is required, remember that your Honda dealer knows your scooter best. If you have the required mechanical "know-how" and tools, your dealer can supply you with an Official Honda Shop Manual to help you perform many maintenance and repair tasks.

Pleasant riding, and thank you for choosing a Honda !

- The following codes in this manual indicate each country.
- The illustrations herein are based on the FJS600A type.

E	UK			
F	France	Belgium		
EK	Hong Kong	New Zealand	South Africa	
	Ireland	Singapore		
ED	European direct sales			
	Austria	Greece	Macedonia	Spain
	Belgium	Holland	Norway	Sweden
	Bulgaria	Hungary	Poland	Switzerland
	Croatia	Iceland	Portugal	Ukraine
	Czech	Israel	Romania	
	Denmark	Italy	Russia	
	Finland	Latvia	Slovakia	
	Germany	Luxembourg	Slovenia	

- The specifications may vary with each locale.

A FEW WORDS ABOUT SAFETY

Your safety, and the safety of others, is very important. And operating this scooter safely is an important responsibility.

To help you make informed decisions about safety, we have provided operating procedures and other information on labels and in this manual. This information alerts you to potential hazards that could hurt you or others.

Of course, it is not practical or possible to warn you about all hazards associated with operating or maintaining a scooter. You must use your own good judgment.

You will find important safety information in a variety of forms, including:

- **Safety Labels** — on the scooter.
- **Safety Messages** — preceded by a safety alert symbol  and one of three signal words: **DANGER, WARNING, or CAUTION.**

These signal words mean:

⚠ DANGER

You **WILL** be **KILLED** or **SERIOUSLY HURT** if you don't follow instructions.

⚠ WARNING

You **CAN** be **KILLED** or **SERIOUSLY HURT** if you don't follow instructions.

⚠ CAUTION

You **CAN** be **HURT** if you don't follow instructions.

- **Safety Headings** — such as Important Safety Reminders or Important Safety Precautions.
- **Safety Section** — such as Scooter Safety.
- **Instructions** — how to use this scooter correctly and safely.

This entire manual is filled with important safety information — please read it carefully.

OPERATION

page

1 SCOOTER SAFETY

- 1 IMPORTANT SAFETY INFORMATION
- 2 PROTECTIVE APPAREL
- 5 LOAD LIMITS AND GUIDELINES
- 10 IMAGE LABELS

15 PARTS LOCATION

- 18 INSTRUMENTS AND INDICATORS

32 MAJOR COMPONENTS

(Information you need to operate this scooter)

- 32 SUSPENSION
- 33 BRAKES
- 38 COOLANT
- 40 FUEL
- 44 ENGINE OIL
- 45 TUBELESS TYRES

page

51 ESSENTIAL INDIVIDUAL COMPONENTS

- 51 IGNITION SWITCH
- 52 KEYS
- 54 IMMOBILIZER SYSTEM (HISS)
- 57 RIGHT HANDLEBAR CONTROLS
- 58 LEFT HANDLEBAR CONTROLS

page

59 FEATURES

(Not required for operation)

- 59 STEERING LOCK
- 60 PARKING BRAKE
- 61 SEAT LOCK
- 62 ADJUSTABLE BACKREST
- 63 HELMET HOLDER
- 64 CENTER COMPARTMENT
- 65 DOCUMENT BAG
- 65 TRUNK LIGHT
- 66 RIGHT COMPARTMENT
- 67 LEFT COMPARTMENT
- 68 ACCESSORY SOCKET
- 69 HEADLIGHT AIM VERTICAL
ADJUSTMENT

page

70 OPERATION

- 70 PRE-RIDE INSPECTION
- 72 STARTING THE ENGINE
- 78 RUNNING-IN
- 79 RIDING
- 87 PARKING
- 88 ANTI-THEFT TIPS

MAINTENANCE

page

89 MAINTENANCE

- 89 THE IMPORTANCE OF MAINTENANCE
- 90 MAINTENANCE SAFETY
- 91 SAFETY PRECAUTIONS
- 92 MAINTENANCE SCHEDULE
- 95 TOOL KIT
- 96 SERIAL NUMBERS
- 97 COLOUR LABEL
- 98 AIR CLEANER
- 101 CRANKCASE BREATHER
- 102 ENGINE OIL
- 109 SPARK PLUGS
- 112 THROTTLE OPERATION
- 113 IDLE SPEED
- 114 COOLANT
- 115 FRONT AND REAR SUSPENSION INSPECTION
- 116 SIDE STAND
- 117 BRAKE PAD WEAR
- 119 BRAKE LOCK OPERATION
- 120 BATTERY
- 122 FUSE REPLACEMENT

page

- 126 BULB REPLACEMENT

133 CLEANING

138 STORAGE GUIDE

- 138 STORAGE
- 140 REMOVAL FROM STORAGE

141 SPECIFICATIONS

145 CATALYTIC CONVERTER

SCOOTER SAFETY

IMPORTANT SAFETY INFORMATION

Your scooter can provide many years of service and pleasure — if you take responsibility for your own safety and understand the challenges that you can meet on the road.

There is much that you can do to protect yourself when you ride. You'll find many helpful recommendations throughout this manual. Following are a few that we consider to be most important.

Always Wear a Helmet

It's a proven fact: helmets significantly reduce the number and severity of head injuries. So always wear an approved motorcycle helmet and make sure your passenger does the same. We also recommend that you wear eye protection, sturdy boots, gloves, and other protective gear (page 2).

Make Yourself Easy to See

Some drivers do not see scooters because they are not looking for them. To make yourself more visible, wear bright reflective clothing, position yourself so other drivers can see you, signal before turning or changing lanes, and use your horn when it will help others notice you.

Ride Within Your Limits

Pushing the limits is another major cause of scooter crashes. Never ride beyond your personal abilities or faster than conditions warrant. Remember that alcohol, drugs, fatigue and inattention can significantly reduce your ability to make good judgements and ride safely.

Don't Drink and Ride

Alcohol and riding don't mix. Even one drink can reduce your ability to respond to changing conditions, and your reaction time gets worse with every additional drink. So don't drink and ride, and don't let your friends drink and ride either.

Keep Your Bike in Safe Condition

For safe riding, it's important to inspect your scooter before every ride and perform all recommended maintenance. Never exceed load limits, and only use accessories that have been approved by Honda for this scooter. See page 5 for more details.

PROTECTIVE APPAREL

For your safety, we strongly recommend that you always wear an approved motorcycle helmet, eye protection, boots, gloves, trousers, and a long-sleeved shirt or jacket whenever you ride. Although complete protection is not possible, wearing proper gear can reduce the chance of injury when you ride.

Following are suggestions to help you choose proper gear.

⚠ WARNING

Not wearing a helmet increases the chance of serious injury or death in a crash.

Be sure you and your passenger always wear a helmet, eye protection and other protective apparel when you ride.

Helmets and Eye Protection

Your helmet is your most important piece of riding gear because it offers the best protection against head injuries. A helmet should fit your head comfortably and securely. A bright-coloured helmet can make you more noticeable in traffic, as can reflective strips.

An open-face helmet offers some protection, but a full-face helmet offers more. Always wear a face shield or goggles to protect your eyes and help your vision.

Additional Riding Gear

In addition to a helmet and eye protection, we also recommend:

- Sturdy boots with non-slip soles to help protect your feet and ankles.
- Leather gloves to keep your hands warm and help prevent blisters, cuts, burns and bruises.
- A motorcycle riding suit or jacket for comfort as well as protection. Bright-coloured and reflective clothing can help make you more noticeable in traffic. Be sure to avoid loose clothes that could get caught on any part of your scooter.

ALWAYS wear a helmet.
You should also wear a face shield or goggles.

Wear bright or reflective clothing.

Clothes should be close-fitting.

Wear gloves.

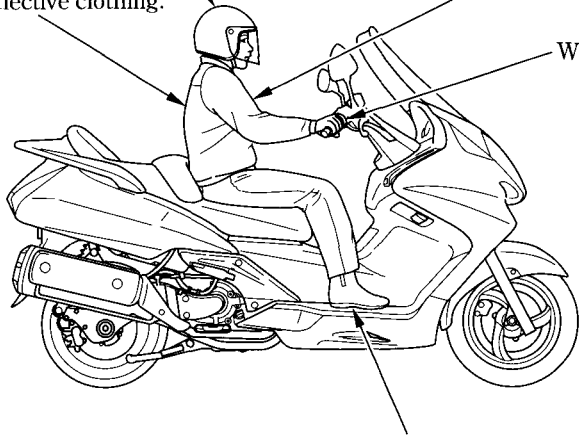

Shoes should be close-fitting, have low heels and offer ankle protection.

LOAD LIMITS AND GUIDELINES

Your scooter has been designed to carry you, one passenger and a limited amount of cargo. When you add cargo or carry a passenger, you may feel some difference during acceleration and braking. But so long as you keep your scooter well-maintained, with good tyres and brakes, you can safely carry loads within the given limits and guidelines.

However, exceeding the weight limit or carrying an unbalanced load can seriously affect your scooter's handling, braking and stability. Non-Honda accessories, improper modifications, and poor maintenance can also reduce your safety margin.

The following pages give more specific information on loading, accessories and modifications.

Loading

How much weight you put on your scooter, and how you load it, are important to your safety. Anytime you ride with a passenger or cargo you should be aware of the following information.

WARNING

Overloading or improper loading can cause a crash and you can be seriously hurt or killed.

Follow all load limits and other loading guidelines in this manual.

Load Limits

Following are the load limits for your scooter:

Maximum weight capacity:

178 kg (392 lb)

Includes the weight of the rider, passenger, all cargo and all accessories

Maximum cargo weight:

17 kg (37 lb)

The weight of added accessories will reduce the maximum cargo weight you can carry.

Putting too much weight in individual storage compartments can also affect stability and handling. So be sure to stay within the limits given below:

Maximum weight:

in center compartment	10 kg (22 lb)
in right compartment	0.5 kg (1.1 lb)
in left compartment	1.0 kg (2.0 lb)

Center compartment:
weight limit:
10 kg (22 lb)

Left compartment:
weight limit:
1.0 kg (2.0 lb)

Right compartment:
weight limit:
0.5 kg (1.1 lb)

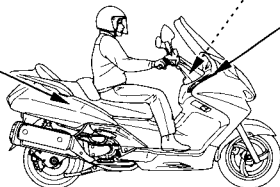

Loading Guidelines

Your scooter is primarily intended for transporting you and a passenger.

If you wish to carry more cargo, check with your Honda dealer for advice, and be sure to read the information regarding accessories on page 8.

Improperly loading your scooter can affect its stability and handling. Even if your scooter is properly loaded, you should ride at reduced speeds whenever carrying cargo.

Follow these guidelines whenever you carry a passenger or cargo:

- Check that both tyres are properly inflated (page 45).
- If you change your normal load, you may need to adjust the rear suspension (page 32).
- To prevent loose items from creating a hazard, make sure the center compartment, right compartment and left compartment are closed and that any other cargo is securely tied down before you ride away.
- Place cargo weight as close to the center of the scooter as possible.
- Balance cargo weight evenly on both sides.

Accessories and Modifications

Modifying your scooter or using non-Honda accessories can make your scooter unsafe. Before you consider making any modifications or adding an accessory, be sure to read the following information.

WARNING

Improper accessories or modifications can cause a crash in which you can be seriously hurt or killed.

Follow all instructions in this owner's manual regarding accessories and modifications.

Accessories

We strongly recommend that you use only Honda Genuine Accessories that have been specifically designed and tested for your scooter. Because Honda cannot test all other accessories, you must be personally responsible for proper selection, installation and use of non-Honda accessories. Check with your dealer for assistance and always follow these guidelines:

- Make sure the accessory does not obscure any lights, reduce ground clearance and banking angle, limit suspension travel or steering travel, alter your riding position or interfere with operating any controls.
- Be sure electrical equipment does not exceed the scooter's electrical system capacity (page 144). A blown fuse can cause a loss of lights or engine power.

- Do not pull a trailer or sidecar with your scooter. This scooter was not designed for these attachments, and their use can seriously impair your scooter's handling.

Modifications

We strongly advise you not to remove any original equipment or modify your scooter in any way that would change its design or operation. Such changes could seriously impair your scooter's handling, stability and braking, making it unsafe to ride.





Removing or modifying your lights, mufflers, emission control system or other equipment can also make your scooter illegal.

IMAGE LABELS

The following pages describe the label meanings. Some labels warn you of potential hazards that could cause serious injury. Others provide important safety information. Read this information carefully and don't remove the labels.

If a label comes off or becomes hard to read, contact your Honda dealer for a replacement.

There is a specific symbol on each label. The meanings of each symbol and label are as follows.

	Read instructions contained in Owner's Manual carefully.
	Read instructions contained in Shop Manual carefully. In the interest of safety, take the motorcycle to be serviced only by a Honda dealer.
	DANGER (with RED background) You WILL be KILLED or SERIOUSLY HURT if you don't follow instructions.
	WARNING (with ORANGE background) You CAN be KILLED or SERIOUSLY HURT if you don't follow instructions.
	CAUTION (with YELLOW background) You CAN be HURT if you don't follow instructions.



RADIATOR CAP LABEL

DANGER

NEVER OPEN WHEN HOT.

Hot coolant will scald you.



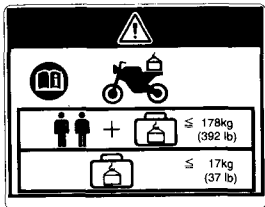



Relief pressure valve begins to open at 1.1 kgf/cm².



ACCESSORIES AND LOADING WARNING LABEL

ACCESSORIES AND LOADING

- The safety stability and handling of this motorcycle may be affected by the addition of accessories and luggage.
- Read carefully the instructions contained in user's manual and installation guide before installing any accessory.
- The total weight of accessories and luggage added to rider's and passenger's weight should not exceed 178 kg (392 lb), which is the maximum weight capacity.
- The luggage weight must not exceed 17 kg (37 lb) under any circumstances.
- The fitting of large fork-mounted or large handlebar-mounted fairing is not recommended.

			200	225
	kPa		200	250
	120/80-14M/C 58S			
	BRIDGESTONE:HOOP B03			
	IRC: SS530F			
	150/70-13M/C 64S			
	BRIDGESTONE:HOOP B02			
	IRC: SS530R			

TYRE INFORMATION LABEL

Cold tyre pressure:

[Driver only]

Front 200 kPa (2.00 kgf/cm², 29 psi)

Rear 225 kPa (2.25 kgf/cm², 33 psi)

[Driver and passenger]

Front 200 kPa (2.00 kgf/cm², 29 psi)

Rear 250 kPa (2.50 kgf/cm², 36 psi)

Tyre size:

Front 120/80 – 14M/C 58S

Rear 150/70 – 13M/C 64S

Tyre brand: BRIDGESTONE



Front HOOP B03

Rear HOOP B02

Tyre brand: IRC

Front SS530F

Rear SS530R

	<p>SAFETY REMINDER LABEL For your protection, always wear helmet and protective gear. FUEL LABEL UNLEAD FUEL ONLY</p>
 <p>≤ 10kg (22 lb)</p>	<p>CARGO LIMIT LABEL Do not exceed 10 kg (22 lb) .</p>
 <p>≤ 1.5kg (3.0 lb)</p>	<p>CARGO LIMIT LABEL Do not exceed 1.5 kg (3.0 lb) .</p>

PARTS LOCATION

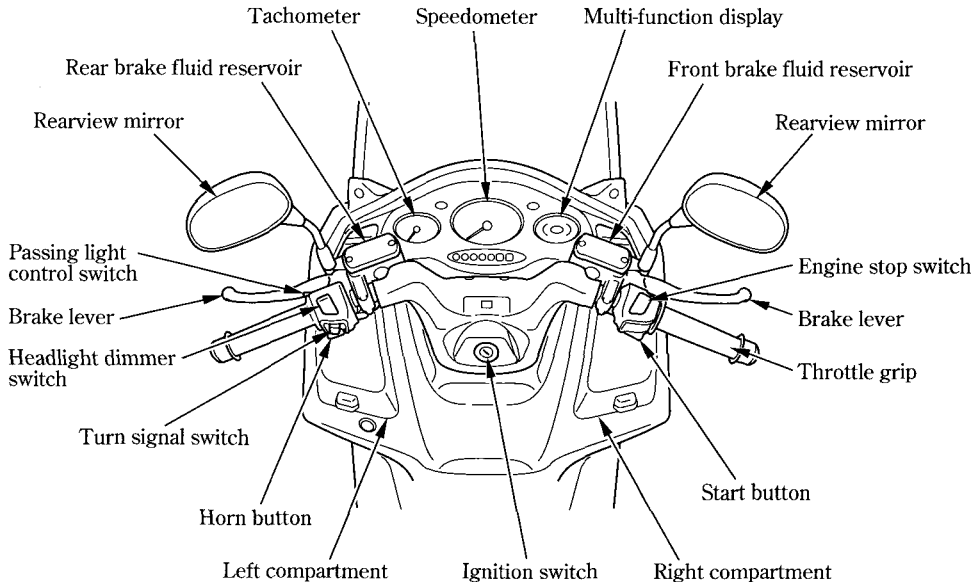

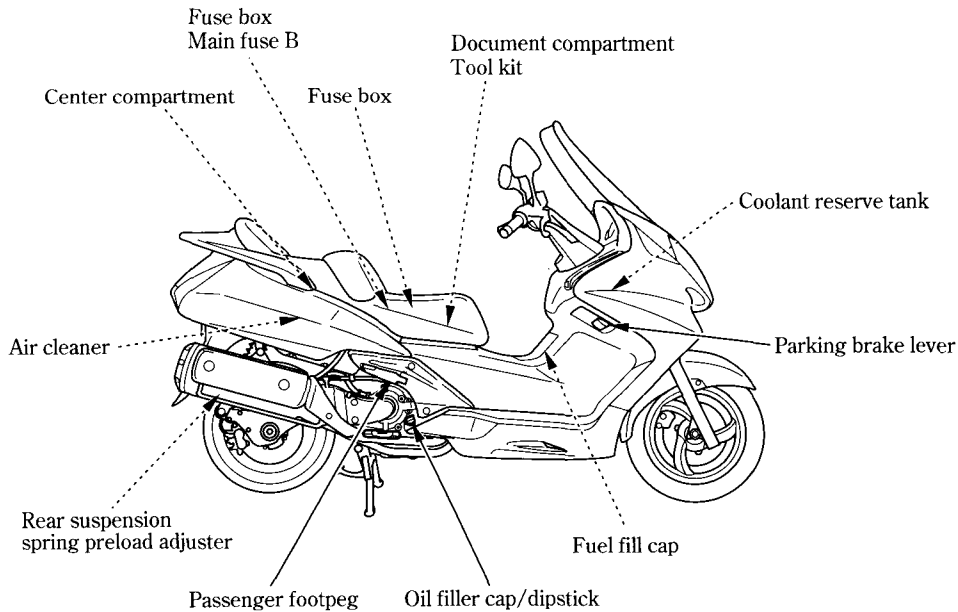

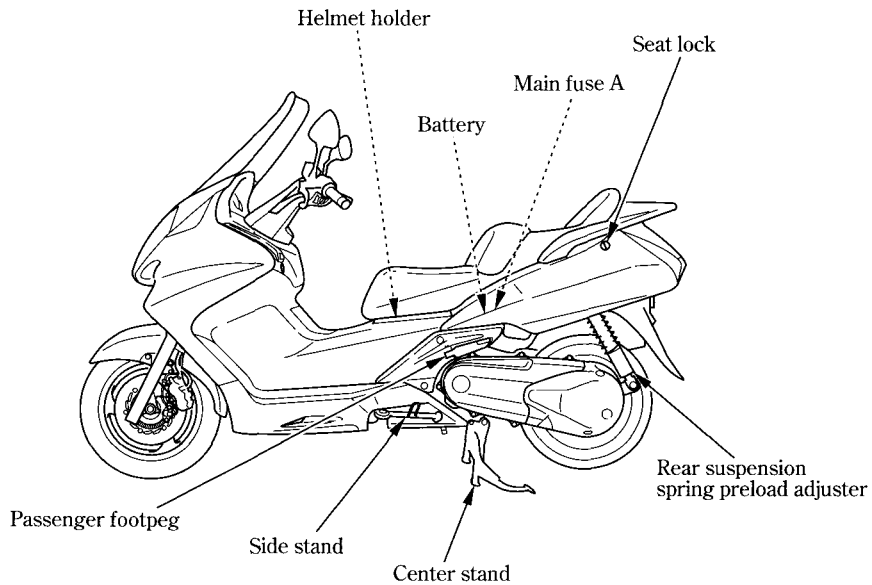

INSTRUMENTS AND INDICATORS

The indicators are contained in the instrument panel. Their functions are described in the tables on the following pages.

- (1) Tachometer
- (2) Tachometer red zone
- (3) Left turn signal indicator
- (4) Speedometer
- (5) Right turn signal indicator
- (6) Multi-function display
- (7) High coolant temperature indicator
- (8) Low oil pressure indicator
- (9) RESET button
- (10) MODE button
- (11) High beam indicator
- (12) V-matic indicator
- (13) PGM-FI malfunction indicator lamp (MIL)
- (14) Parking brake indicator
- (15) Anti-lock brake system (ABS) indicator (FJS600A)
- (16) Immobilizer system (HISS) indicator

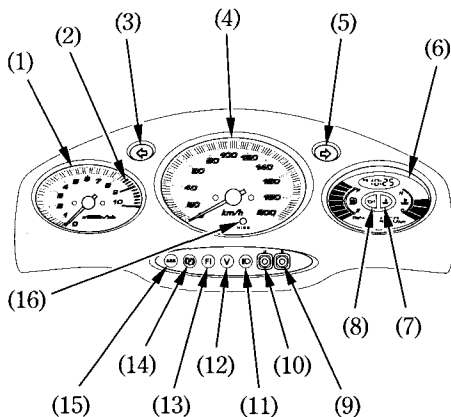

(Ref.No.) Description	Function
(1) Tachometer	Shows engine revolutions per minute.
(2) Tachometer red zone	<p>Never allow the tachometer needle to enter the red zone, even after the engine has been broken in.</p> <p>NOTICE</p> <p>Running the engine beyond recommended maximum engine speed (the beginning of the tachometer red zone) can damage the engine.</p>
(3) Left turn signal indicator (green)	Flashes when the left turn signal operates.
(4) Speedometer	<p>Shows riding speed.</p> <p>This shows your speed in kilometers per hour (km/h) and/or miles per hour (mph) depending on the type.</p>
(5) Right turn signal indicator (green)	Flashes when the right turn signal operates.

(Ref.No.) Description	Function
(6) Multi-function display	The display includes the following functions; This display shows the initial display (page 25).
Coolant temperature gauge	Shows coolant temperature (page 27).
Fuel gauge	Shows approximate fuel supply available (page 28).
Odometer	Shows accumulated mileage (page 29).
Tripmeter	Shows mileage per trip (page 29).
Digital clock	Shows hour and minute (page 30).

(Ref.No.) Description	Function
(7) High coolant temperature indicator (red)	<p>Lights when the coolant is over the specified temperature. Should also lights for a few seconds and then go off when the ignition switch is turned ON. If the indicator goes on while riding, stop the engine and check the reserve tank coolant level. Read pages 38 – 39 and do not ride the scooter until the problem has been corrected.</p> <p>NOTICE</p> <p>Exceeding maximum running temperature may cause serious engine damage.</p>
(8) Low oil pressure indicator (red)	<p>Lights when the engine oil pressure is below normal operating range. Should light when ignition switch is ON and engine is not running. Should go out when the engine starts, except for occasional flickering at or near idling speed when engine is warm.</p> <p>NOTICE</p> <p>Running the engine with insufficient oil pressure may cause serious engine damage.</p>

(Ref.No.) Description	Function
(9) RESET button	<p>This button is used to reset the tripmeter (page 29) or to adjust the time (page 30).</p> <p>This button is also used to flash the immobilizer system (HISS) indicator when the ignition switch is OFF (page 55).</p>
(10) MODE button	<p>The button is used to select the tripmeter A, the tripmeter B, or the odometer (page 29).</p> <p>This button is also used to adjust the time (page 30).</p>
(11) High beam indicator (blue)	<p>Lights when the headlight is on high beam.</p>
(12) V-matic indicator (amber)	<p>Lights when the V-matic parts have to be replaced. Should also light for a few seconds and then go off when the ignition switch is turned ON.</p> <p>When this indicator lights, contact your Honda dealer.</p>

(Ref.No.) Description	Function
(13) PGM-FI malfunction indicator lamp (MIL) (red)	<p>Flashes when there is any abnormality in the PGM-FI (Programmed Fuel Injection) system. Should also light for a few seconds and then go off when the ignition switch is turned ON and engine stop switch is at ○ (RUN).</p> <p>If it comes on at any other time, reduce speed and take the scooter to your Honda dealer as soon as possible.</p>
(14) Parking brake indicator (red)	Lights when the parking brake is applied.
(15) Anti-lock Brake System (ABS) indicator (red) (FJS600A)	This light normally comes on when the ignition is turned ON, and goes off after you ride the scooter at speed above 10 km/h (6 mph). If there is a problem with the Anti-lock Brake System, this light comes on and remains on (page 35).

(Ref.No.) Description	Function
(16) Immobilizer system (HISS) indicator (red)	<p>This indicator lights for a few seconds when the ignition switch is turned ON and the engine stop switch is at \odot (RUN). It will then go off if the properly-coded key has been inserted. If an improperly-coded key has been inserted, the indicator will remain on and the engine will not start (page 54).</p> <p>This indicator can continue to flash every 2 seconds for 24 hours with the ignition switch OFF. After this period, the indicator automatically switches off (page 55).</p>

Initial Display

When the ignition switch is turned ON, the multi-function display (1) will show from bottom up in sequence. Thereafter, it will temporarily show all the modes so that you can make sure the liquid crystal display is functioning properly.

The unit “mile” (2) will be displayed only for E type.

Digital clock (3) and tripmeter (4) will reset if the battery is disconnected.

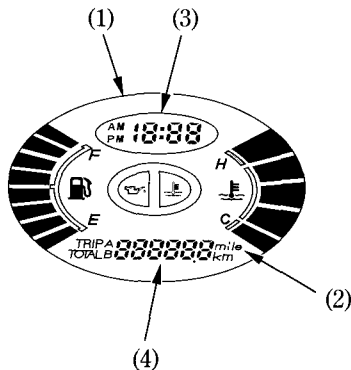

- (1) Multi-function display
- (2) “mile”
- (3) Digital clock
- (4) Tripmeter

Multi-function Display

Multi-function display includes the following functions:

Coolant temperature gauge

Fuel gauge

Odometer/Tripmeter

Digital clock

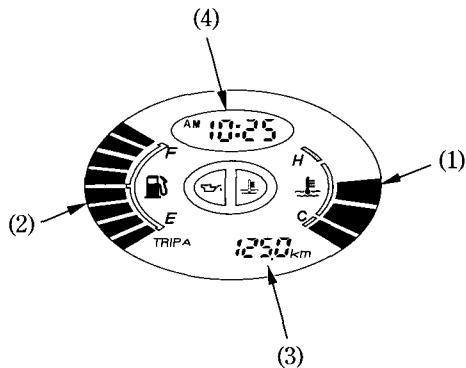

- (1) Coolant temperature gauge
- (2) Fuel gauge
- (3) Odometer/Tripmeter
- (4) Digital clock

Coolant Temperature Gauge

The coolant temperature gauge (1) shows coolant temperature.

When the segment C (2) goes on, the engine is warm enough for the scooter to be ridden. The normal operating temperature range is within the section between the segment C and segment H (3).

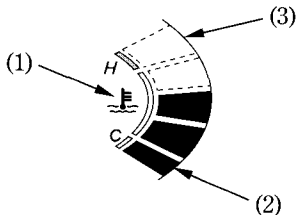

- (1) Coolant temperature gauge
- (2) Segment C
- (3) Segment H

Overheating Message:

When the coolant is over specified temperature, the segment H and high coolant temperature indicator (4) goes on. If this occurs, stop the engine and check the reserve tank coolant level. Read pages 38 – 39 and do not ride the scooter until the problem has been corrected.

NOTICE

Exceeding maximum running temperature may cause serious engine damage.

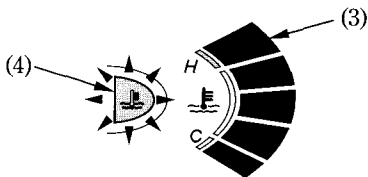

- (4) High coolant temperature indicator

Fuel Gauge

The fuel gauge liquid crystal display (1) shows the approximate fuel supply available in a graduated display. When the segment F (2) goes on, the fuel tank capacity including reserve is:

16.0 ℓ (4.23 US gal , 3.52 Imp gal)

When segment E (3) flashes, fuel will be low and you should refill the tank as soon as possible.

The amount of fuel left in the tank with the vehicle set upright is approximately:

3.5 ℓ (0.92 US gal , 0.77 Imp gal)

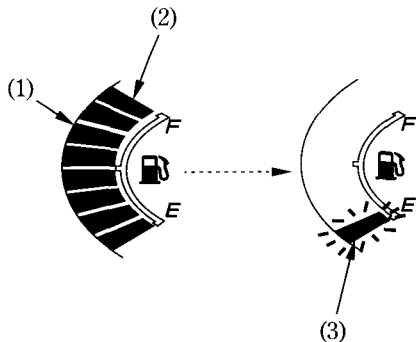

- (1) Fuel gauge
- (2) Segment F
- (3) Segment E

Odometer/Tripmeter

The odometer (1) shows accumulated mileage.

The tripmeter shows mileage per trip. There are two tripmeters, tripmeter A (2) and tripmeter B (3).

Push the MODE button (4) to select the odometer, tripmeter A and tripmeter B.

To reset the tripmeter, push and hold the RESET button (5) when the display is in the tripmeter A or tripmeter B.

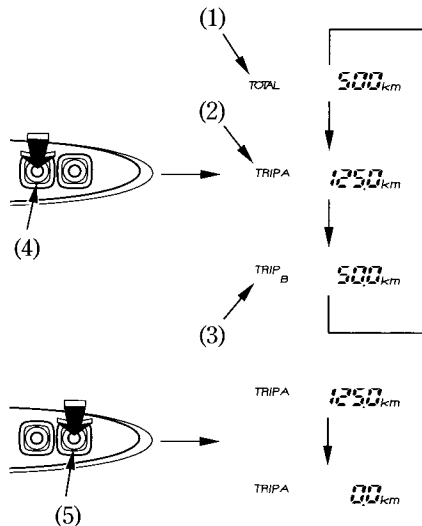

- (1) Odometer
- (2) Tripmeter A
- (3) Tripmeter B

- (4) MODE button
- (5) RESET button

Digital Clock

Shows hour and minute. To adjust the time, proceed as follows:

1. Turn the ignition switch ON.
2. Press and hold both the MODE button (2) and RESET button (3) for more than 2 seconds. The clock will be set in the adjust mode with the hour display flashing.

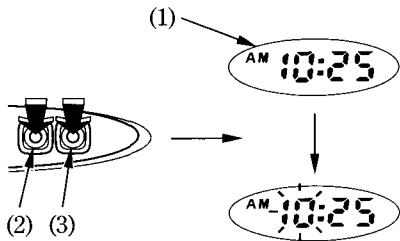

3. To set the hour, press the RESET button until the desired hour and AM/PM are displayed.

- The time is advanced by one hour each time the button is pressed.
- Quick setting – press and hold the RESET button until the desired hour appears.

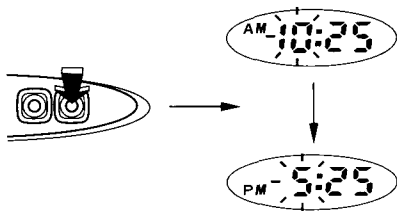

- (1) Digital clock
(2) MODE button
(3) RESET button

4. Press the MODE button. The minute display will start flashing.

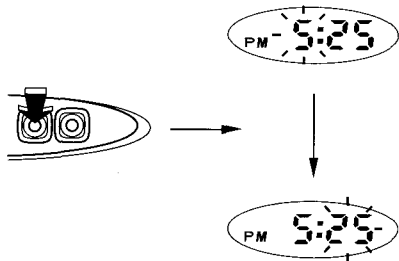

5. To set the minute, press the RESET button until the desired minute. The minute display will return to "00" when "60" is reached without affecting the hour display.

- The time is advanced by one minute, each time the button is pressed.
- Quick setting — press and hold the RESET button until the desired minute appears.

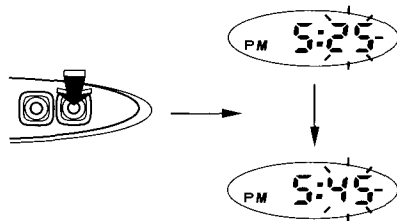

6. To end the adjustment, press the MODE button or turn the ignition switch OFF. The display will stop flashing automatically and the adjustment will be cancelled if the button is not pressed for about 2 minutes.

MAJOR COMPONENTS

(Information you need to operate this scooter)

SUSPENSION

Each shock absorber (1) has 5 adjustment positions for different load or riding conditions.

Use a pin spanner (2) to adjust the rear shocks.

Always adjust the shock absorber position in sequence (1-2-3-4-5 or 5-4-3-2-1).

Attempting to adjust directly from 1 to 5 or 5 to 1 may damage the shock absorber.

Position 1 is for light loads and smooth road conditions. Positions 3 to 5 increase spring preload for a stiffer rear suspension, and can be used when the scooter is heavily loaded. Be certain to adjust both shock absorbers to the same position.

Standard position: 2

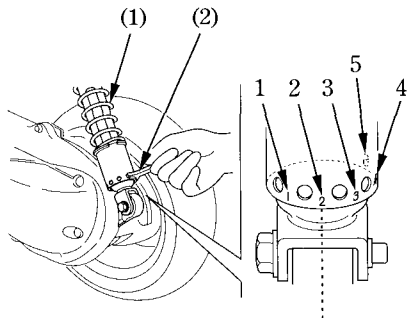

(1) Shock absorber

(2) Pin spanner

BRAKES

Combined Brake System (CBS)

This scooter is equipped with a Combined Brake System. Operating the rear brake lever applies the rear brake and a portion of the front brake. For full braking effectiveness, use both the front and rear brake lever simultaneously, as you would with a conventional scooter braking system.

As with a conventional scooter braking system, excessively hard application of the brake controls may cause wheel lock, reducing control of the scooter.

For normal braking, apply both the front and rear brake lever to match your road speed. For maximum braking, close the throttle and firmly apply the front and rear brake lever.

Anti-lock Brake System (ABS) (FJS600A)

This model is also equipped with an Anti-lock Brake System (ABS) designed to help prevent wheel lock up during hard braking on uneven or other poor surfaces while running straight. Although the wheel may not lock up – if you are braking too hard in a turn the scooter can still lose traction, causing a loss of control.

In some situations, a scooter with ABS may require a longer stopping distance to stop on loose or uneven surfaces than an equivalent scooter without ABS.

ABS cannot make up for road conditions, bad judgment, or improper operation of the brakes. It is still your responsibility to ride at reasonable speeds for weather, road surface, and traffic conditions, and to leave a margin of safety.

ABS is self-checking and always on.

- ABS may be activated by riding over a sharp drop or rise in the road level. It is important to follow the tyre recommendations (page 49). The ABS computer works by comparing wheel speed. Non-recommended tyres can affect wheel speed and may confuse the ABS computer.
- ABS does not function at low speeds (approximately 10 km/h (6 mph) or below).
- ABS does not function if the battery is discharged.

ABS Indicator Light (FJS600A)

Normally, this light comes on when the ignition switch is turned ON, and goes off after you ride the scooter at speed above 10 km/h (6 mph). If there is an ABS problem, the indicator light comes on and remains on. The ABS system does not operate when the ABS indicator light is on.

If the ABS indicator light comes on while riding, stop the scooter in a safe place and turn off the engine.

Turn the ignition ON again. The light should come on, and go off after you ride the scooter at speeds above 10 km/h (6 mph). If it does not go off, ABS is not functioning, but the brakes still work the Combined Brake System and provide normal stopping ability. However, you should have the system checked by Honda dealer as soon as possible.

The ABS indicator light may come on if you turn the rear wheel while the scooter is upright on the stand. This is normal. Turn the ignition OFF, then turn it ON. The indicator should come on, then go off after you run the scooter above 30 km/h (19 mph).

Both the front and rear brakes are the hydraulic disc types.

As the brake pads wear, the brake fluid level drops.

There are no adjustments to perform, but fluid level and pad wear must be inspected periodically. The system must be inspected frequently to ensure there are no fluid leaks. If the control lever free travel becomes excessive and the brake pads are not worn beyond the recommended limit (page 117), there is probably air in the brake system and it must be bled. See your Honda dealer for this service.

Front Brake Fluid Level:

With the scooter in an upright position, check the fluid level. It should be above the LOWER level mark (1). If the level is at or below the LOWER level mark, check the brake pads for wear (page 117).

Worn pads should be replaced. If the pads are not worn, have your brake system inspected for leaks.

The recommended brake fluid is Honda DOT 4 brake fluid from a sealed container, or an equivalent.

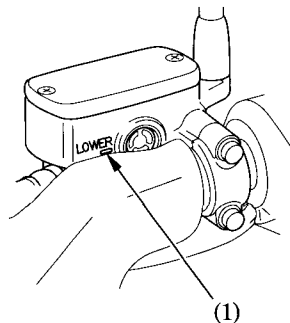

(1) LOWER level mark

Rear Brake Fluid Level:

With the scooter in an upright position, check the fluid level. It should be above the LOWER level mark (1). If the level is at or below the LOWER level mark, check the brake pads for wear (page 118).

Worn pads should be replaced. If the pads are not worn, have your brake system inspected for leaks.

The recommended brake fluid is Honda DOT 4 brake fluid from a sealed container, or an equivalent.

Other Checks:

Make sure there are no fluid leaks. Check for deterioration or cracks in the hoses and fittings.

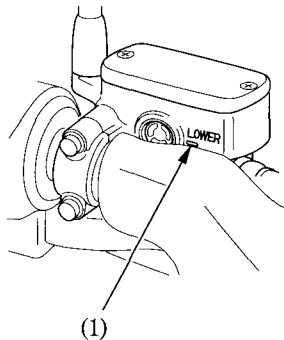

(1) LOWER level mark

COOLANT

Coolant Recommendation

The owner must properly maintain the coolant to prevent freezing, overheating, and corrosion. Use only high quality ethylene glycol antifreeze containing corrosion protection inhibitors specifically recommended for use in aluminum engines. (SEE ANTIFREEZE CONTAINER LABEL).

Use only low-mineral drinking water or distilled water as a part of the antifreeze solution. Water that is high in mineral content or salt may be harmful to the aluminum engine.

Using coolant with silicate inhibitors may cause premature wear of water pump seals or blockage of radiator passages.

Using tap water may cause engine damage.

The factory provides a 50/50 solution of antifreeze and distilled water in this scooter. This coolant solution is recommended for most operating temperatures and provides good corrosion protection. A higher concentration of antifreeze decreases the cooling system performance and is recommended only when additional protection against freezing is needed. A concentration of less than 40/60 (40% antifreeze) will not provide proper corrosion protection. During freezing temperatures, check the cooling system frequently and add higher concentrations of antifreeze (up to a maximum of 60% antifreeze) if required.

Inspection

The reserve tank is inside of front fairing. Check the coolant level in the reserve tank (1) while the engine is at the normal operating temperature with the scooter in an upright position. If the coolant level is below the LOWER level mark (2), remove the right compartment (page 66) and reserve tank cap (4) and add coolant mixture until it reaches the UPPER level mark (3). Always add coolant to the reserve tank. Do not attempt to add coolant by removing the radiator cap.

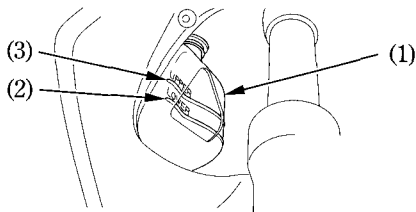

- (1) Reserve tank
(2) LOWER level mark
(3) UPPER level mark

If the reserve tank is empty, or if coolant loss is excessive, check for leaks and see your Honda dealer for repair.

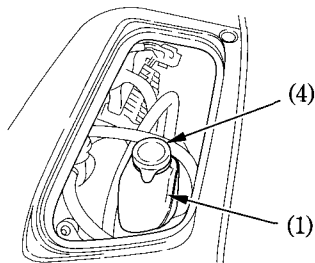

- (1) Reserve tank
(4) Reserve tank cap

FUEL

Fuel Tank

The fuel tank is located under the step board.

The fuel tank capacity including the reserve supply is:

16.0 ℓ (4.23 US gal , 3.52 Imp gal)

Open the fuel tank lid (1).

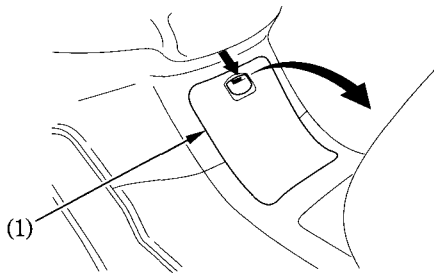

(1) Fuel tank lid

To open the fuel fill cap (2), insert the ignition key (3) and turn the key clockwise until it stops and rotate the fuel fill cap counterclockwise until it clicks. Lift off the fuel fill cap.

Do not overfill the tank. There should be no fuel in the filler neck (4).

After refueling, be sure to tighten the fuel fill cap firmly by turning it clockwise.

Make sure that the arrow marks (5) on the fuel fill cap and fuel tank are aligned.

Turn the key counterclockwise until it stops and remove the key.

Close the fuel tank lid.

⚠ WARNING

Petrol is highly flammable and explosive. You can be burned or seriously injured when handling fuel.

- Stop the engine and keep heat, sparks, and flame away.
- Refuel only outdoors.
- Wipe up spills immediately.

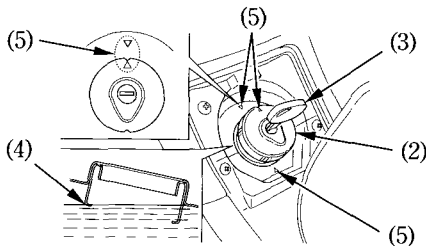

(2) Fuel fill cap
(3) Ignition key

(4) Filler neck
(5) Arrow marks

Use unleaded petrol with a research octane number of 91 or higher.

The use of leaded petrol will cause premature damage to the catalytic converter.

NOTICE

If “spark knock” or “pinking” occurs at a steady engine speed under normal load, change brands of petrol. If spark knock or pinking persists, consult your Honda dealer. Failure to do so is considered misuse, and damage caused by misuse is not covered by Honda’s Limited Warranty.

Petrol Containing Alcohol

If you decide to use a petrol containing alcohol (gasohol), be sure it's octane rating is at least as high as that recommended by Honda. There are two types of "gasohol": one containing ethanol, and the other containing methanol. Do not use petrol that contains more than 10 % ethanol. Do not use petrol containing methanol (methyl or wood alcohol) that does not also contain cosolvents and corrosion inhibitors for methanol. Never use petrol containing more than 5 % methanol, even if it has cosolvents and corrosion inhibitors.

Fuel system damage or engine performance problems resulting from the use of fuels that contain alcohol is not covered under the warranty. Honda cannot endorse the use of fuels containing methanol since evidence of their suitability is as yet incomplete.

Before buying fuel from an unfamiliar station, try to find out if the fuel contains alcohol. If it does, confirm the type and percentage of alcohol used. If you notice any undesirable operating symptoms while using a petrol that contains alcohol, or one that you think contains alcohol, switch to a petrol that you know does not contain alcohol.

ENGINE OIL

Engine Oil Level Check

Check the engine oil level each day before riding the scooter.

The level must be maintained between the upper (1) and lower (2) level marks on the oil filler cap/dipstick (3).

1. Start the engine and let it idle for 3–5 minutes. Make sure the low oil pressure indicator goes off. If the light remains on, stop the engine immediately.
2. Stop the engine and put the scooter on its center stand on level ground.
3. After 2–3 minutes, remove the oil filler cap/dipstick, wipe it clean, and reinsert the oil filler cap/dipstick without screwing it in. Remove the oil filler cap/dipstick. The oil level should be between the upper and lower level marks on the oil filler cap/dipstick.
4. If required, add the specified oil (page 102) up to the upper level mark. Do not overfill.

5. Reinstall the oil filler cap/dipstick. Check for oil leaks.

NOTICE

Running the engine with insufficient oil pressure may cause serious engine damage.

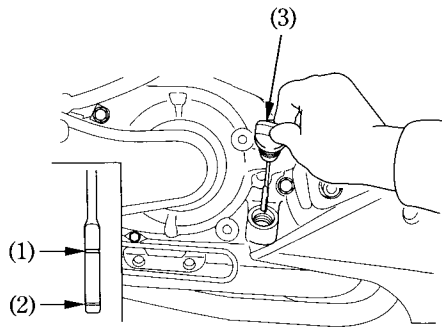

- (1) Upper level mark
(2) Lower level mark

- (3) Oil filler cap/dipstick

TUBELESS TYRES

To safely operate your scooter, your tyres must be the proper type and size, in good condition with adequate tread, and correctly inflated for the load you are carrying. The following pages give more detailed information on how and when to check your air pressure, how to inspect your tyres for damage, and what to do when your tyres need to be repaired or replaced.

WARNING

Using tyres that are excessively worn or improperly inflated can cause a crash in which you can be seriously hurt or killed.

Follow all instructions in this owner's manual regarding tyre inflation and maintenance.

Air Pressure

Keeping your tyres properly inflated provides the best combination of handling, tread life and riding comfort. Generally, underinflated tyres wear unevenly, adversely affect handling, and are more likely to fail from being overheated.

Overinflated tyres make your scooter ride harshly, are more prone to damage from road hazards, and wear unevenly.

We recommend that you visually check your tyres before every ride and use a gauge to measure air pressure at least once a month or any time you think the tyres might be low.

Tubeless tyres have some self-sealing ability if they are punctured. However, because leakage is often very slow, you should look closely for punctures whenever a tyre is not fully inflated.

Always check air pressure when your tyres are “cold” – when the scooter has been parked for at least three hours. If you check air pressure when your tyres are “warm” – when the scooter has been ridden for even a few miles – the readings will be higher than if the tyres were “cold”. This is normal, so do not let air out of the tyres to match the recommended cold air pressures given below. If you do, the tyres will be underinflated.

The recommended “cold” tyre pressures are:

kPa (kgf/cm ² , psi)		
Driver only	Front	200 (2.00 , 29)
	Rear	225 (2.25 , 33)
Driver and one passenger	Front	200 (2.00 , 29)
	Rear	250 (2.50 , 36)

Inspection

Whenever you check the tyre pressures, you should also examine the tyre treads and sidewalls for wear, damage, and foreign objects:

Look for:

- Bumps or bulges in the side of the tyre or the tread. Replace the tyre if you find any bumps or bulges.
- Cuts, splits or cracks in the tyre. Replace the tyre if you can see fabric or cord.
- Excessive tread wear.

Also, if you hit a pothole or hard object, pull to the side of the road as soon as you can safely and carefully inspect the tyres for damage.

Tread Wear

Replace tyres before tread depth at the center of the tyre reaches the following limit:

Minimum tread depth	
Front:	1.5 mm (0.06 in)
Rear:	2.0 mm (0.08 in)

<For Germany>

German law prohibits use of tyres whose tread depth is less than 1.6 mm.

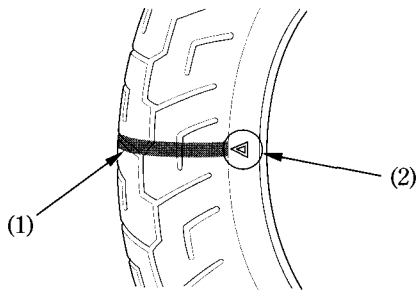

- (1) Wear indicator
- (2) Wear indicator location mark

Tyre Repair

If a tyre is punctured or damaged, you should replace it, not repair it. As discussed below, a tyre that is repaired, either temporarily or permanently, will have lower speed and performance limits than a new tyre.

A temporary repair, such as an external tubeless tyre plug, may not be safe for normal speeds and riding conditions. If a temporary or emergency repair is made to a tyre, you should ride slowly and cautiously to a dealer and have the tyre replaced. If possible, you should not carry a passenger or cargo until a new tyre is installed.

Even if a tyre is professionally repaired with a permanent internal patch plug, it will not be as good as a new tyre. You should not exceed 80 km/h (50 mph) for the first 24 hours, or 130 km/h (80 mph) at any time thereafter. In addition, you may not be able to safely carry as much weight as with a new tyre. Therefore, we strongly recommend that you replace a damaged tyre. If you choose to have a tyre repaired, be sure the wheel is balanced before you ride.

Tyre Replacement

The tyres that came on your scooter were designed to match the performance capabilities of your scooter and provide the best combination of handling, braking, durability and comfort.

WARNING

Installing improper tyres on your scooter can affect handling and stability. This can cause a crash in which you can be seriously hurt or killed.

Always use the size and type of tyres recommended in this owner's manual.

The recommended tyres for your scooter are:

Front: 120/80 – 14M/C 58S
BRIDGESTONE
HOOP B03
IRC
SS530F

Rear: 150/70 – 13M/C 64S
BRIDGESTONE
HOOP B02
IRC
SS530R

Type: bias-ply, tubeless

Whenever you replace a tyre, use one that is equivalent to the original and be sure the wheel is balanced after the new tyre is installed.

Important Safety Reminders

- Do not install a tube inside a tubeless tyre on this scooter. Excessive heat build-up can cause the tube to burst.
- Use only tubeless tyres on this scooter. The rims are designed for tubeless tyres, and during hard acceleration or braking, a tube-type tyre could slip on the rim and cause the tyre to rapidly deflate.

ESSENTIAL INDIVIDUAL COMPONENTS

IGNITION SWITCH

The ignition switch (1) is below the steering stem.

The headlight, position lights, taillights and license light will come on whenever you turn the ignition switch ON. If your scooter is stopped with the ignition switch ON and the engine is not running, the headlight, position lights, taillights and license light will still be on, resulting in battery discharge.

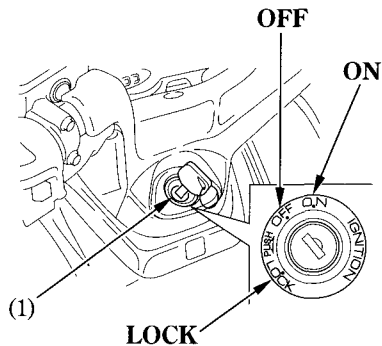

(1) Ignition switch

Key Position	Function	Key Removal
LOCK (steering lock)	Steering is locked. Engine and lights cannot be operated.	Key can be removed
OFF	Engine and lights cannot be operated.	Key can be removed
ON	Engine and lights can be operated.	Key cannot be removed

KEYS

This scooter has two keys (1) and a key number plate (2).

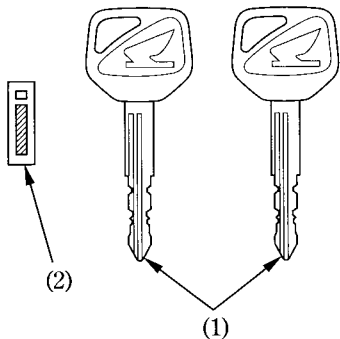

(1) Keys

(2) Key number plate

You will need the key number if you ever have to replace a key. Store the plate in a safe place.

To reproduce keys, bring all keys, key number plate and scooter to your Honda dealer.

Up to four keys can be registered with the immobilizer system (HISS), including the ones in hand.

If all keys are lost, the PGM-FI unit/ignition control module must be replaced. To avoid this possibility we recommend that if only one key is left, you immediately have it reproduced to ensure that a back-up is available.

These keys contain electronic circuits that are activated by the immobilizer system (HISS). They will not work to start the engine if the circuits are damaged.

- Do not drop the keys or set heavy objects on them.
- Do not grind, drill or in any way alter the original shape of the keys.
- Keep the keys away from magnetic objects.

IMMOBILIZER SYSTEM (HISS)

HISS is the abbreviation of Honda Ignition Security System.

The immobilizer system (HISS) protects your scooter from theft. A properly-coded key must be used in the ignition switch for the engine to start. If an improperly-coded key (or other device) is used the engine's starting circuit is disabled.

When the ignition switch is turned ON and the engine stop switch is at “  ” (RUN), the immobilizer system (HISS) indicator lights for a few seconds, then goes off. If the indicator remains on, it means the system does not recognize the coding of the key. Turn the ignition switch to OFF, remove the key, reinsert and turn the switch ON again.

The immobilizer system (HISS) indicator can continue flashing every 2 seconds for 24 hours with the ignition switch OFF. After that, the indicator automatically switches off.

To activate the indicator function, carry out the following:

1. Turn the ignition switch ON.
2. Have the odometer displayed (page 29).
3. Press the RESET button (1) for more than 2 seconds.

The immobilizer system (HISS) indicator (2) will flash once to indicate that the function has been activated.

4. Turn the ignition switch OFF. As you pull out the key, the indicator will start to blink.

When the ignition switch is turned ON again, the indicator function will be cancelled.

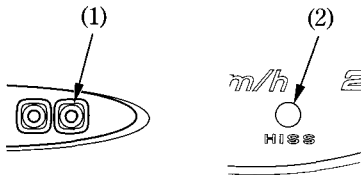

- (1) RESET button
- (2) Immobilizer system (HISS) indicator

If the system repeatedly does not recognize the coding of your key, contact your Honda dealer.

- The system may not recognize the key's coding if any other immobilizer key is near the ignition switch. To make sure the system recognizes the key code, keep each immobilizer key on a separate ring.
- Do not attempt to alter the immobilizer system (HISS) or add other devices to it. Electrical problems could result, making it impossible to start your scooter.
- If all keys are lost, the PGM-FI unit/ignition control module must be replaced.

EC Directives

This immobilizer system complies with the R & TTE (Radio equipment and telecommunications terminal equipment and the mutual recognition of their conformity) Directive.





The declaration of conformity to R & TTE Directive is provided to the owner at the time of purchase. The declaration of conformity should be kept at a safe place. When the declaration of conformity is lost or is not provided, contact your Honda dealer.

< South Africa only >



RIGHT HANDLEBAR CONTROLS

Engine Stop Switch

The engine stop switch (1) is next to the throttle grip. When the switch is in the  (RUN) position, the engine will operate. When the switch is in the  (OFF) position, the engine will not operate. This switch is intended primarily as a safety or emergency switch and should normally remain in the  (RUN) position.

If your scooter is stopped with the ignition switch ON and the engine stop switch  (OFF), the headlight, position lights, taillights, and license light will still be on, resulting in battery discharge.

Start Button

The start button (2) is below the engine stop switch.

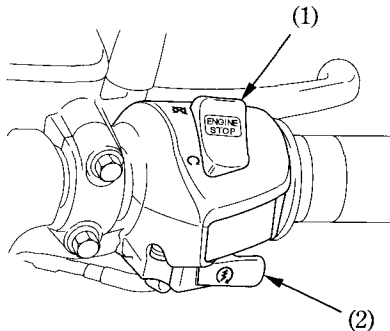

When the start button is pressed, the starter motor cranks the engine. If the engine stop switch is in the  (OFF) position, the starter motor will not operate. See page 72 for the starting procedure.



- (1) Engine stop switch
- (2) Start button

LEFT HANDLEBAR CONTROLS



Headlight Dimmer Switch (1)

Push the dimmer switch to  D (HI) to select high beam or to  D (LO) to select low beam.

Passing Light Control Switch (2)

When this switch is pressed, the headlight flashes on to signal approaching cars or when passing.

Turn Signal Switch (3)

Move to  to signal a left turn,  to signal a right turn. Press to turn signal off.

Horn Button (4)

Press the button to sound the horn.

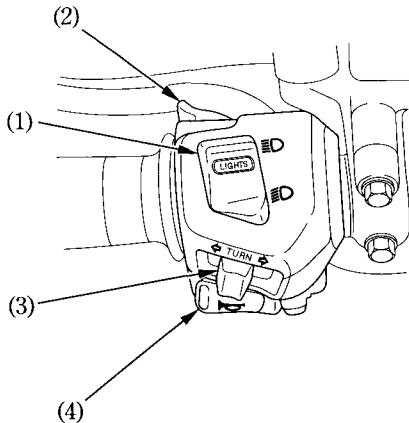

- (1) Headlight dimmer switch
- (2) Passing light control switch
- (3) Turn signal switch
- (4) Horn button

FEATURES

(Not required for operation)

STEERING LOCK

To lock the steering, turn the handlebars all the way to the left or right, turn the ignition key (1) to LOCK while pushing in. Remove the key.

To unlock the steering, turn the key to OFF while pushing in.

Do not turn the key to LOCK while riding the scooter; loss of vehicle control will result.

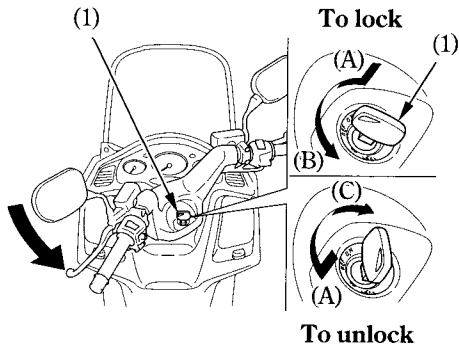

(1) Ignition key

(A) Push in

(B) Turn to LOCK

(C) Turn to OFF

PARKING BRAKE

The scooter is equipped with a parking brake.

To Apply the Parking Brake:

Pull in the parking brake lever (1) to lock the rear wheel.

To Release the Parking Brake:

Release the parking brake lever while lightly pulling in the lever.

Before riding, check that the parking brake indicator is turned OFF and make sure that the rear brake is fully released so there is no drag on the rear wheel.

To apply

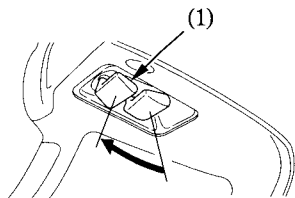

To release

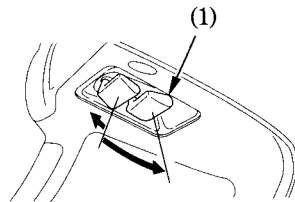

(1) Parking brake lever

SEAT LOCK

The seat lock (1) is on the left side below the seat.

To lift the seat, insert the ignition key (2) and turn it clockwise to unlock.

Pull the seat up.

To lock the seat, lower and push down on the reverse side of the hooks (3) of the seat until it locks.

Before riding, make sure the seat is closed securely. If not closed, the trunk light will remain lit, resulting in battery discharge.

Do not place luggage or clothing near the seat catch (4). It could make the seat difficult to open if it gets caught between the seat hook and catch while closing the seat.

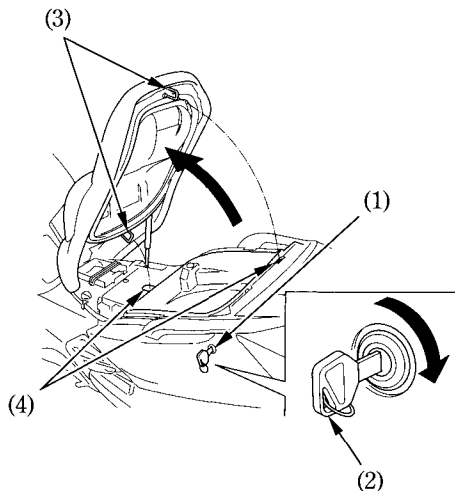

- (1) Seat lock
- (2) Ignition key

- (3) Hooks
- (4) Seat catch

ADJUSTABLE BACKREST

The seat is equipped with a backrest (1) which allows the seat to be adjusted according to the riders preference or physical condition.

To Adjust:

Open the seat (page 61), remove the bolts (2) on the back and move the backrest back and forth according to the riders preference or physical condition.

Install the bolts.

After cleaning or running in the rain, wipe off water collected under the backrest before the scooter again.

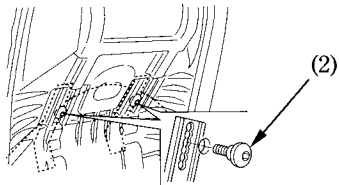
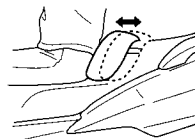
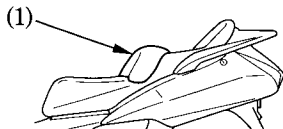

(1) Backrest

(2) Bolts

HELMET HOLDER

The helmet holder eliminates the need for carrying your helmet after parking.

Insert the ignition key into the seat lock, and turn it clockwise to open the seat.

Hang the helmet on the holder hook (1).
Close the seat and lock it securely.

⚠ WARNING

Riding with a helmet attached to the holder can interfere with the rear wheel or suspension and could cause a crash in which you can be seriously hurt or killed.

Use the helmet holder only while parked. Do not ride with a helmet secured by the holder.

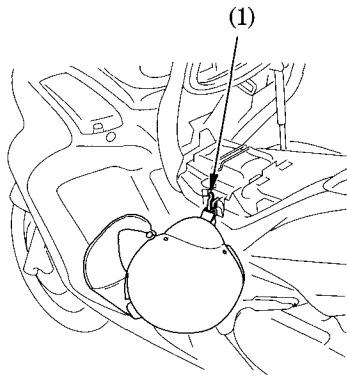

(1) Holder hook

CENTER COMPARTMENT

The center compartment (1) is below the seat. Opening and closing:
See “SEAT LOCK” (page 61).

MAXIMUM WEIGHT LIMIT:

10 kg (22 lb)

Never exceed the maximum weight limit; handling and stability may be severely affected.

The center compartment may become heated by the engine. Do not store food and other articles which are flammable or susceptible to heat damage in this compartment.

Do not direct water under pressure against the center compartment as water will be forced into the compartment.

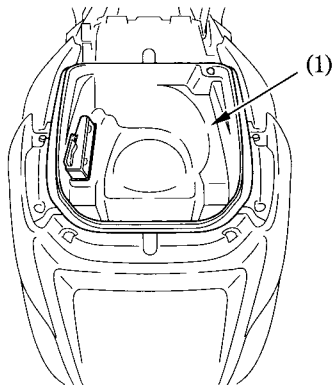

(1) Center compartment

DOCUMENT BAG

The document bag (1) is in the document compartment (2) under the seat (3).

This owner's manual and other documents should be stored in the document bag. When washing your scooter, be careful not to flood this area with water.

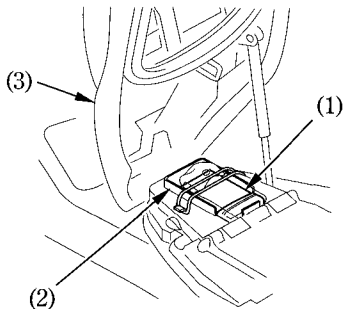

- (1) Document bag
- (2) Document compartment

(3) Seat

TRUNK LIGHT

The trunk light (1) will be turned ON automatically when the seat is opened. It is kept ON as long as the seat is opened regardless of the position of the ignition switch.

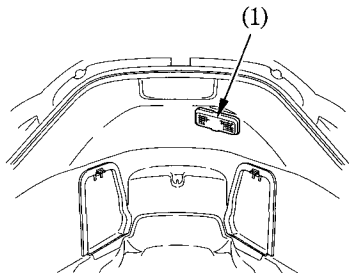

(1) Trunk light

RIGHT COMPARTMENT

There is right compartment (1) below the right side of the handlebar.

The maximum allowable load in the right compartment shall be no more than 0.5 kg (1.1 lb).

Do not open the right compartment while riding the scooter.

To Open:

- Push and hold the knob (2), then open the right compartment cover (3).

To Remove:

1. Open the right compartment cover.
2. Remove the screw (4).
3. Pry up on the edge of the right compartment to release the right and left hooks (5) as shown.
4. Close the right compartment cover.
5. Pull up the right compartment.

Make sure the right compartment cover is closed before riding.

When washing your scooter be careful not to flood this area with water.

Do not store valuables or fragile articles in the right compartment.

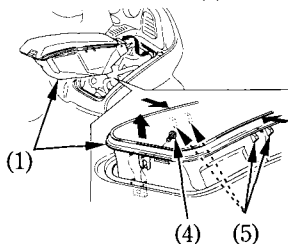
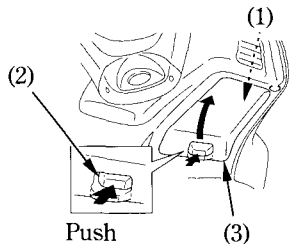

- | | |
|-----------------------------|-----------|
| (1) Right compartment | (4) Screw |
| (2) Knob | (5) Hooks |
| (3) Right compartment cover | |

LEFT COMPARTMENT

There is left compartment (1) below the left side of the handlebar.

The maximum allowable load in the left compartment shall be no more than 1.0 kg (2.0 lb).

Do not open the left compartment while riding the scooter.

To Open:

- Insert the ignition key (2) and turn it clockwise.
Push and hold the knob (3), then open the left compartment cover (4).

To Close:

1. Close the left compartment cover and turn the ignition key counterclockwise.
2. Remove the key.

Make sure the left compartment cover is closed before riding.

When washing your scooter be careful not to flood this area with water.

Do not store valuables or fragile articles in the left compartment.

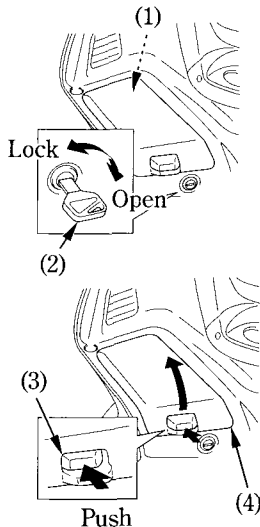

- (1) Left compartment
- (2) Ignition key
- (3) Knob
- (4) Left compartment cover

ACCESSORY SOCKET

The accessory socket (1) is in the left compartment.

Open the cover (2) to gain access to the accessory socket.

Rated capacity is

12 watts (12 volt, 1 amps).

To prevent battery run down or weak battery, keep the engine running while drawing current from the socket.

Set the headlight in the LO beam. Battery run down or damage to the accessory socket cause result.

To prevent entry foreign matter, be sure to close the cover when the accessory socket is not used.

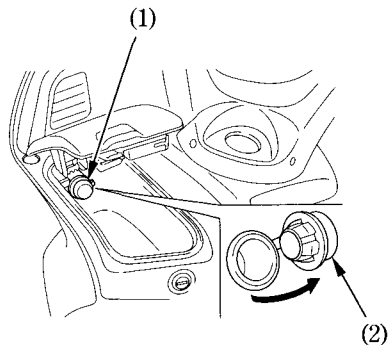

(1) Accessory socket

(2) Cover

HEADLIGHT AIM VERTICAL ADJUSTMENT

Vertical adjustment can be made by turning the bolt (1) in or out as necessary. Obey local laws and regulations.

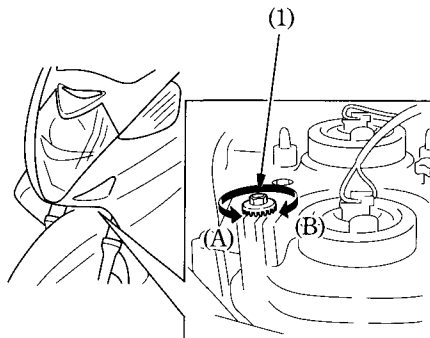

(1) Bolt

(A) Up

(B) Down

OPERATION

PRE-RIDE INSPECTION

For your safety, it is very important to take a few moments before each ride to walk around your scooter and check its condition. If you detect any problem, be sure you take care of it, or have it corrected by your Honda dealer.

WARNING

Improperly maintaining this scooter or failing to correct a problem before riding can cause a crash in which you can be seriously hurt or killed.

Always perform a pre-ride inspection before every ride and correct any problems.

1. Engine oil level—add engine oil if required (page 44). Check for leaks.
2. Fuel level—fill fuel tank when necessary (page 40). Check for leaks.
3. Coolant level—add coolant if required. Check for leaks (pages 38 – 39).
4. Front and rear brakes—check operation; make sure there is no brake fluid leakage (pages 33 – 37).

5. Tyres—check condition and pressure (pages 45 – 50).
6. Throttle—check for smooth opening and full closing in all steering positions (page 112).
7. Lights and horn—check that headlight, brake/tail lights, position lights, license light, turn signals, indicators and horn function properly.
8. Engine stop switch—check for proper function (page 57).
9. Side stand ignition cut-off system—check for proper function (page 116).

STARTING THE ENGINE

Always follow the proper starting procedure described below.

This scooter is equipped with a side stand ignition cut-off system. The engine cannot be started if the side stand is down. A running engine will shut off if the side stand is lowered.

To protect the catalytic converter in your scooter's exhaust system, avoid extending idling and the use of leaded petrol.

Your scooter's exhaust contains poisonous carbon monoxide gas. High levels of carbon monoxide can collect rapidly in enclosed areas such as a garage. Do not run the engine with the garage door closed. Even with the door open, run the engine only long enough to move your scooter out of the garage.

Do not use the electric starter for more than 5 seconds at a time. Release the start button for approximately 10 seconds before pressing it again.

1. Place the scooter on its center stand.
2. Lock the rear wheel by applying the parking brake lever (1).

⚠ CAUTION

Contact with the spinning rear wheel can cause you to be hurt.

Set the parking brake when the scooter is on its center stand.

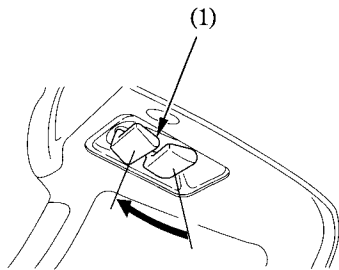

(1) Parking brake lever

3. Make sure that the engine stop switch is at  (RUN).
4. Turn the ignition switch (2) to ON.

Confirm the following:

- The low oil pressure indicator is ON.
- The immobilizer system (HISS) indicator is OFF.
- The PGM-FI malfunction indicator lamp (MIL) is OFF.

The low oil pressure indicator should go off 2–3 seconds after the engine starts. If the low oil pressure indicator lights during operation, stop the engine immediately and check the engine oil level.

NOTICE

Operating the engine with insufficient oil pressure can cause serious engine damage.

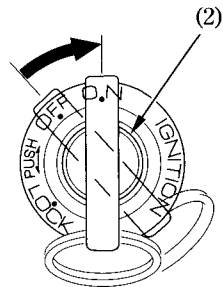

(2) Ignition switch

5. Squeeze the rear brake lever (3).
The electric starter will only work when the rear brake lever is squeezed and the side stand is up.

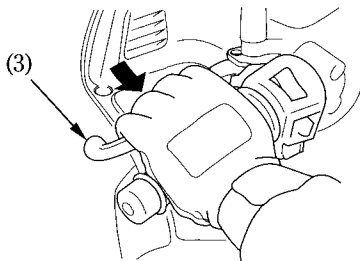

(3) Rear brake lever

6. With the throttle closed, push the start button (4). Release the start button as soon as the engine starts.

The engine will not start if the throttle is fully open (because the electronic control module cuts off the fuel supply).

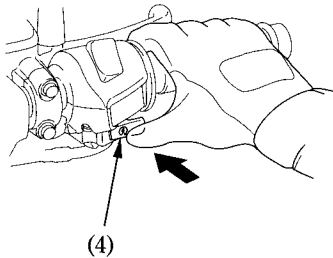

(4) Start button

7. Be sure to keep the throttle closed and the parking brake locked while warming up the engine.
8. Allow the engine to warm up before riding (See **“RIDING”**, page 79).

Do not “BLIP” the throttle (open and close rapidly) as the scooter will move forward suddenly.

Do not leave the scooter unattended while the engine is warming up.

Snapping the throttle or fast idling for more than about 5 minutes at normal air temperature may cause exhaust pipe discoloration.

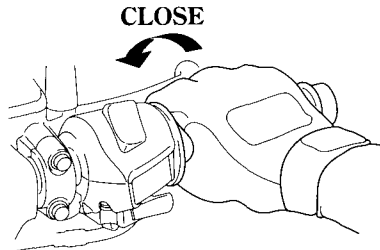

Flooded Engine

If the engine fails to start after repeated attempts, it may be flooded.

1. Leave the engine stop switch set to  (RUN).
2. Open throttle fully.
3. Press the start button for 5 seconds.
4. Follow the normal starting procedure.
5. If the engine starts with unstable idle, open the throttle slightly.
If the engine does not start, wait for 10 seconds, then follow steps 1–4 again.

Ignition Cut Off

Your scooter is designed to automatically stop the engine and fuel pump if the scooter is over-turned (a banking sensor cuts off the ignition system). Before restarting the engine, you must turn the ignition switch to the OFF position and then back to ON.

RUNNING-IN

Help assure your scooter's future reliability and performance by paying extra attention to how you ride during the first 500 km (300 miles).

During this period, avoid full-throttle starts and rapid acceleration.

RIDING

Review Scooter Safety (pages 1 – 9) before you ride.

Make sure flammable materials such as dry grass or leaves do not come in contact with the exhaust system when riding, idling, or parking your scooter.

1. **Make sure the throttle is closed and the parking brake is locked** before moving the scooter off the center stand.

The rear wheel must be locked when moving the scooter off the center stand or loss of control may result.

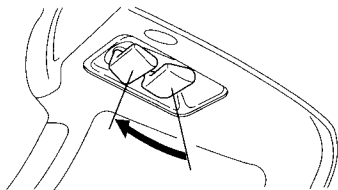

2. Stand on the left side of the scooter and push it forward and off the center stand.

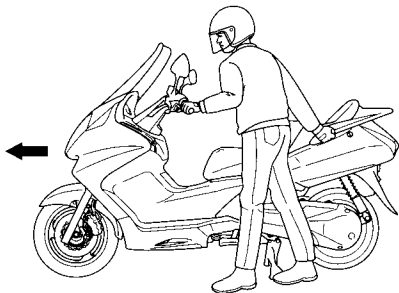

3. Mount the scooter from the left side keeping at least one foot on the ground to steady the scooter.

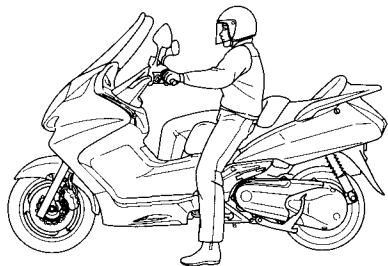

4. Unlock the rear wheel by releasing the parking brake lever (1).

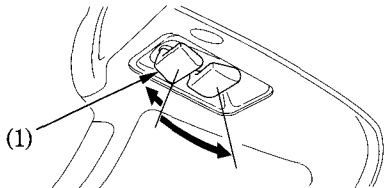

(1) Parking brake lever

5. **Before starting off**, indicate your direction with the turn signals, and check for safe traffic conditions. Grasp the handlebars firmly with both hands.

Never attempt one-handed operation; loss of vehicle control could result.

6. **To accelerate**, open the throttle (2) gradually; the scooter will move forward.

Do not “BLIP” the throttle (open and close rapidly) as the scooter will move forward suddenly, causing possible loss of control.

7. **To decelerate**, close the throttle.

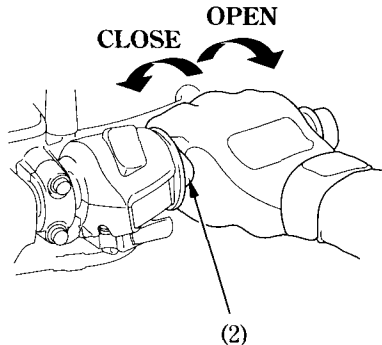

(2) Throttle

8. **When slowing down the scooter,** coordination of the throttle (2) and front and rear brakes (3) is most important.

Both front and rear brakes should be applied together. Independent use of only the front or rear brake reduces stopping performance.

Excessive brake application may cause either wheel to lock, reducing control of the scooter.

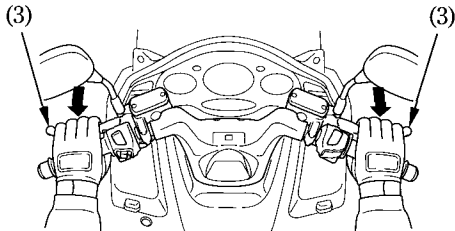
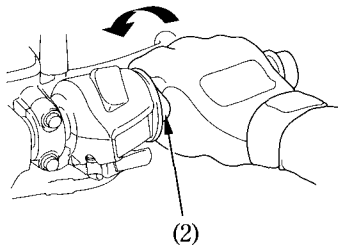

- (2) Throttle
(3) Front and rear brakes

9. When approaching a corner or turn, close the throttle (2) fully, and slow the scooter down by applying both front (4) and rear (5) brakes at the same time.

10. After completing the turn, open the throttle gradually to accelerate the scooter.

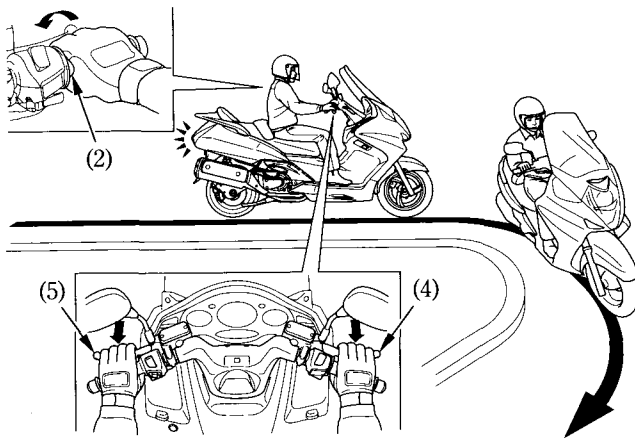

(2) Throttle (4) Front brake (5) Rear brake

11. **When descending a steep grade**, close the throttle (2) fully and apply both brakes (3) to slow the scooter.

Avoid continuous use of the brakes, which may result in overheating and reduction of braking efficiency.

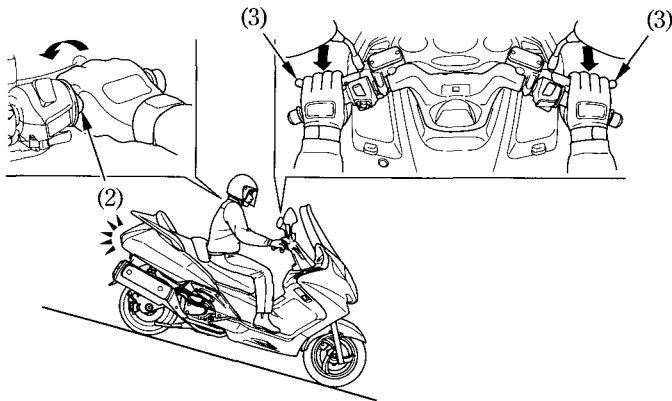

(2) Throttle (3) Front and rear brakes

12. When riding on wet or loose surfaces,
be especially cautious.

When riding in wet or rainy conditions or on loose surfaces, the ability to maneuver and stop will be reduced. For your safety:

- Exercise extreme caution when braking, accelerating or turning.
- Ride at slower speeds and allow for extra stopping distance.
- Keep the scooter as upright as possible.
- Use extreme caution when riding over slippery surfaces such as railroad tracks, iron plates, manhole covers, painted lines, etc.

PARKING

1. After stopping the scooter turn the ignition switch to the "OFF" position and remove the key.
2. Use the center stand to support the scooter while parked.

Park the scooter on firm, level ground to prevent it from falling over.

If you must park on a slight incline, aim the front of the scooter uphill to reduce the possibility of rolling off the center stand or overturning.

3. Lock the steering to help prevent theft (page 59).

The exhaust pipe and muffler become very hot during operation and remain sufficiently hot to inflict burns if touched even after shutting off the engine.

Make sure flammable materials such as dry grass or leaves do not come in contact with the exhaust system when parking your scooter.

HOW TO USE CENTER STAND

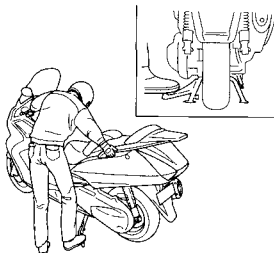

ANTI-THEFT TIPS

1. Always lock the steering and never leave the key in the ignition switch. This sounds simple but people do forget.
2. Be sure the registration information for your scooter is accurate and current.
3. Park your scooter in a locked garage whenever possible.
4. Use an additional anti-theft device of good quality.
5. Put your name, address, and phone number in this Owner's Manual and keep it on your scooters at all times. Many times stolen scooters are identified by information in the Owner's Manuals that are still with them.

NAME: _____

ADDRESS: _____

PHONE NO: _____

LOCK STEERING

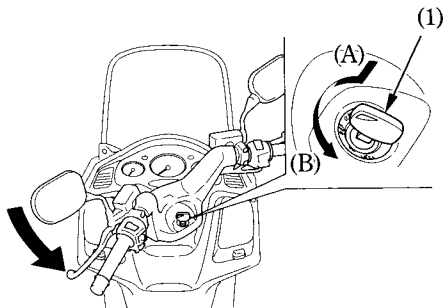

(1) Ignition key

(A) Push in

(B) Turn to LOCK

MAINTENANCE

THE IMPORTANCE OF MAINTENANCE

A well-maintained scooter is essential for safe, economical and trouble-free riding. It will also help reduce air pollution.

To help you properly care for your scooter, the following pages include a Maintenance Schedule and a Maintenance Record for regularly scheduled maintenance.

These instructions are based on the assumption that the scooter will be used exclusively for its designed purpose. Sustained high speed operation or operation in unusually wet or dusty conditions will require more frequent service than specified in the Maintenance Schedule. Consult your Honda dealer for recommendations applicable to your individual needs and use.

If your scooter overturns or becomes involved in a crash, be sure your Honda dealer inspects all major parts, even if you are able to make some repairs.

WARNING

Improperly maintaining this scooter or failing to correct a problem before you ride can cause a crash in which you can be seriously hurt or killed.

Always follow the inspection and maintenance recommendations and schedules in this owner's manual.

MAINTENANCE SAFETY

This section includes instructions on some important maintenance tasks. You can perform some of these tasks with the tools provided — if you have basic mechanical skills.

Other tasks that are more difficult and require special tools are best performed by professionals. Wheel removal should normally be handled only by a Honda technician or other qualified mechanic; instructions are included in this manual only to assist in emergency service.

Some of the most important safety precautions follow. However, we cannot warn you of every conceivable hazard that can arise in performing maintenance. Only you can decide whether or not you should perform a given task.

⚠ WARNING

Failure to properly follow maintenance instructions and precautions can cause you to be seriously hurt or killed.

Always follow the procedures and precautions in this owner's manual.

SAFETY PRECAUTIONS

- Make sure the engine is off before you begin any maintenance or repairs. This will help eliminate several potential hazards:
 - * **Carbon monoxide poisoning from engine exhaust.**
Be sure there is adequate ventilation whenever you operate the engine.
 - * **Burns from hot parts.**
Let the engine and exhaust system cool before touching.
 - * **Injury from moving parts.**
Do not run the engine unless instructed to do so.
- Read the instructions before you begin, and make sure you have the tools and skills required.
- To help prevent the scooter from falling over, park it on a firm, level surface, using the center stand to provide support.

- Be sure the rear brake lock is set before running the engine while the scooter is supported by the center stand. This will prevent the rear wheel from spinning and avoid the possibility of someone being injured from contacting the wheel.
- To reduce the possibility of a fire or explosion, be careful when working around petrol or batteries. Use only nonflammable solvent, not petrol, to clean parts. Keep cigarettes, sparks and flames away from the battery and all fuel-related parts.

Remember that your Honda dealer knows your scooter best and is fully equipped to maintain and repair it.

To ensure the best quality and reliability, use only new Honda Genuine Parts or their equivalents for repair and replacement.

MAINTENANCE SCHEDULE

Perform the Pre-ride Inspection (page 70) at each scheduled maintenance period.

I: INSPECT AND CLEAN, ADJUST, LUBRICATE OR REPLACE IF NECESSARY

C: CLEAN R: REPLACE A: ADJUST L: LUBRICATE

The following Maintenance Schedule specifies all maintenance required to keep your scooter in peak operating condition. Maintenance work should be performed in accordance with standards and specifications of Honda by properly trained and equipped technicians. Your Honda dealer meets all of these requirements.

- * Should be serviced by your Honda dealer, unless the owner has proper tools and service data and is mechanically qualified. Refer to the Official Honda Shop Manual.
- ** In the interest of safety, we recommend these items be serviced only by your Honda dealer.

Honda recommends that your Honda dealer should road test your scooter after each periodic maintenance is carried out.

- NOTES:
- (1) At higher odometer readings, repeat at the frequency interval established here.
 - (2) Service more frequently when riding in unusually wet or dusty areas.
 - (3) Service more frequently when riding in rain or at full throttle.
 - (4) Inspect every 18,000 km (12,000 mi) after replacement.
 - (5) Replace every 2 years, or at indicated odometer interval, whichever comes first. Replacement requires mechanical skill.
 - (6) Replace every 2 years. Replacement requires mechanical skill.

ITEM	FREQUENCY	WHICHEVER → COMES FIRST ↓ NOTE	ODOMETER READING [NOTE (1)]								REFER TO PAGE
			× 1,000 km	1	6	12	18	24	30	36	
			× 1,000 mi	0.6	4	8	12	16	20	24	
* FUEL LINE					I		I		I	—	
* THROTTLE OPERATION					I		I		I	112	
AIR CLEANER	NOTE (2)					R			R	98–100	
CRANKCASE BREATHER	NOTE (3)			C	C	C	C	C	C	101	
SPARK PLUGS					R		R		R	109	
* VALVE CLEARANCE							I			—	
ENGINE OIL			R		R		R		R	102	
ENGINE OIL FILTER			R		R		R		R	105	
* ENGINE OIL STRAINER SCREEN					C		C		C	105	
* ENGINE IDLE SPEED			I	I	I	I	I	I	I	113	
RADIATOR COOLANT	NOTE (5)				I		I		R	38–39, 114	
* COOLING SYSTEM					I		I		I	—	
* SECONDARY AIR SUPPLY SYSTEM					I		I		I	—	

ITEM	FREQUENCY	WHICHEVER → COMES FIRST ↓ NOTE	ODOMETER READING [NOTE (1)]								REFER TO PAGE	
			× 1,000 km	1	6	12	18	24	30	36		
			× 1,000 mi	0.6	4	8	12	16	20	24		
		NOTE	MONTH									
* DRIVE BELT		NOTE (4)					I	R				—
* BELT CASE AIR CLEANER						C		C				—
* FINAL DRIVE OIL		NOTE (6)										—
BRAKE FLUID		NOTE (5)			I	I	R	I	I	R		36–37
BRAKE PADS WEAR					I	I	I	I	I	I		117, 118
BRAKE SYSTEM					I		I			I		33–37, 117, 118
* BRAKELIGHT SWITCH						I		I		I		—
* BRAKE LOCK OPERATION					I	I	I	I	I	I		119
* HEADLIGHT AIM							I		I			69
** CLUTCH SHOES WEAR						I	I	I	I	I		—
SIDE STAND							I		I			116
* SUSPENSION							I		I			115
* NUTS, BOLTS, FASTENERS						I		I		I		—
** WHEELS/TYRES							I		I			—
** STEERING HEAD BEARINGS						I		I		I		—

TOOL KIT

The tool kit (1) is under the seat (page 61). Some roadside repairs, minor adjustments and parts replacement can be performed with the tools contained in the kit.

- Spark plug wrench
- 10 × 12 mm Box end wrench
- 14 × 17 mm Open end wrench
- 5 mm Hex wrench
- No. 2 Phillips screwdriver
- No. 2 screwdriver
- Screwdriver handle
- Pin spanner
- Tool bag

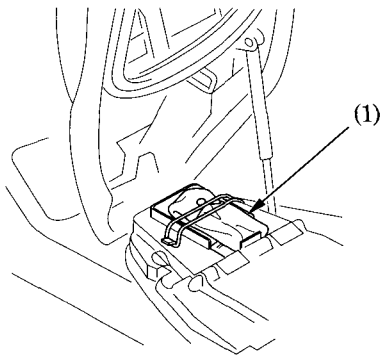

(1) Tool kit

SERIAL NUMBERS

The frame and engine serial numbers are required when registering your scooter. They may also be required by your dealer when ordering replacement parts. Record the numbers here for your reference.

FRAME NO. _____

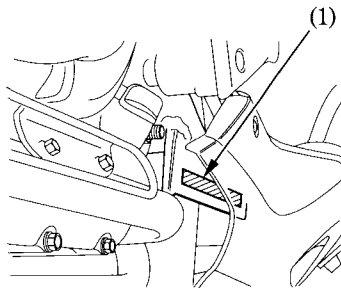

(1) Frame number

96

The frame number (1) is stamped on the right side of the frame body.

The engine number (2) is stamped on the left side of the crankcase.

ENGINE NO. _____

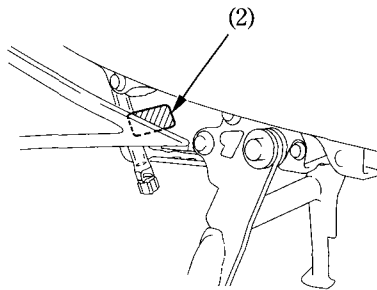

(2) Engine number

COLOUR LABEL

The colour label (1) is attached to the center compartment (page 64).

It is helpful when ordering replacement parts. Record the colour and code here for your reference.

COLOUR _____

CODE _____

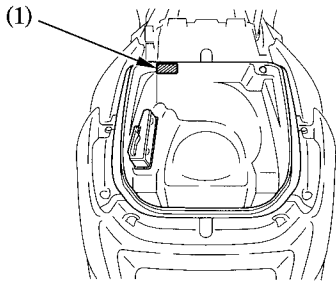

(1) Colour label

AIR CLEANER

Refer to the Safety Precautions on page 91 .

The air cleaner should be serviced at regular intervals (page 93). Service more frequently when riding in unusually wet or dusty areas.

1. Remove the screws A (1) and rear cover (2).
2. Open the seat (page 61).

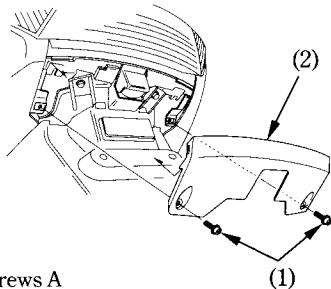

- (1) Screws A
(2) Rear cover

3. Remove the screws B (3).

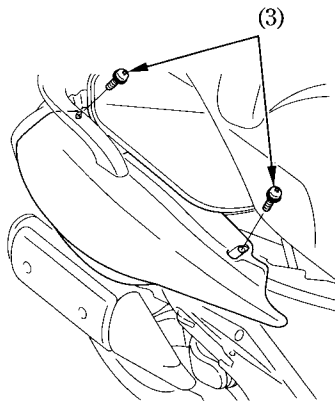

- (3) Screws B

4. Remove the hook A (4) from the side of turn signal light case (5).
5. Remove the hooks B (6) from the slots B (7).
6. Remove the prongs (8) from the grommets (9).
7. Remove the hooks C (10) from the slots C (11).

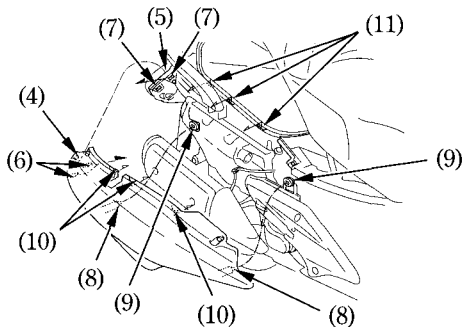

- | | |
|----------------------------|--------------|
| (4) Hook A | (8) Prongs |
| (5) Turn signal light case | (9) Grommets |
| (6) Hooks B | (10) Hooks C |
| (7) Slots B | (11) Slots C |

8. Release the wire harness (12) from the guide (13).
9. Remove the air cleaner cover (14) by removing the screws C (15).

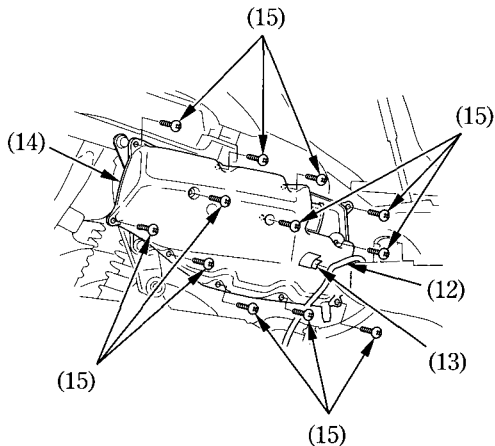

- | | |
|-------------------|------------------------|
| (12) Wire harness | (14) Air cleaner cover |
| (13) Guide | (15) Screws C |

10. Remove the air cleaner (16) by removing the screw D (17).
11. Discard the air cleaner.
12. Install a new air cleaner.
Use the Honda Genuine air cleaner or an equivalent air cleaner specified for your model. Using the wrong Honda air cleaner or a non-Honda air cleaner which is not of equivalent quality may cause premature engine wear or performance problems.
13. Install the removed parts in the reverse order of removal.
 - Make sure that the wire harness is installed in the guide securely.

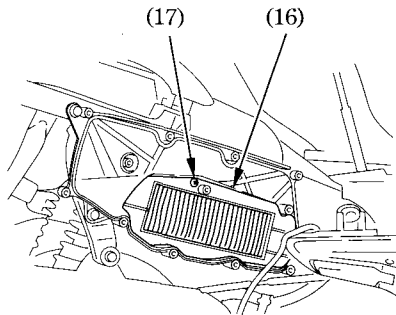

(16) Air cleaner
(17) Screw D

CRANKCASE BREATHER

Refer to the Safety Precautions on page 91 .

1. Remove the crankcase breather tube plug (1) from the tube and drain deposits into a suitable container.
2. Reinstall the crankcase breather tube plug.

Service more frequently when riding in rain, at full throttle, or after the scooter is washed or overturned. Service if the deposit level can be seen in the transparent section of the drain tube.

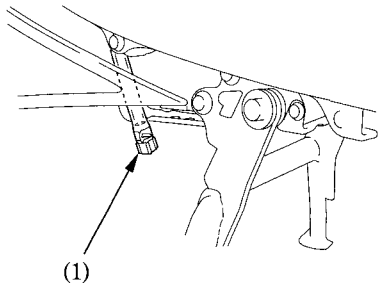

(1) Crankcase breather tube plug

ENGINE OIL

Refer to the Safety Precautions on page 91 .

Oil Recommendation

API classification	SG or higher except oils labeled as energy conserving on the circular API service label
Viscosity	SAE 10W-30
JASO T 903 standard	MB

Suggested Oil
Honda "4-STROKE MOTORCYCLE OIL" or equivalent.

Your scooter does not need oil additives. Use the recommended oil.

Do not use API SH or higher oils displaying a circular API "energy conserving" service label on the container. They may affect lubrication and clutch performance.

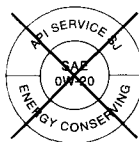

NOT RECOMMENDED

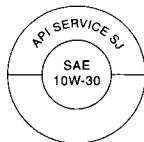

OK

Do not use non-detergent, vegetable, or castor based racing oils.

Viscosity:

Viscosity grade of engine oil should be based on average atmospheric temperature in your riding area. The following provides a guide to the selection of the proper grade or viscosity of oil to be used at various atmospheric temperatures.

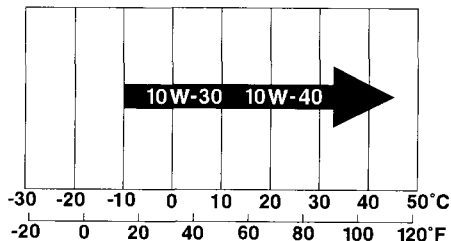

JASO T 903 standard

The JASO T 903 standard is an index for engine oils for 4-stroke motorcycle engines.

There are two classes: MA and MB.

Oil conforming to the standard is labeled on the oil container. For example, the following label shows the MB classification.

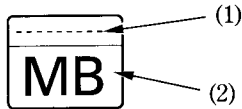

PRODUCT MEETING JASO T 903
COMPANY GUARANTEEING THIS MB PERFORMANCE:

- (1) Code number of the sales company
of the oil
- (2) Oil classification

Engine Oil, Oil Filter and Oil Strainer Screen

Engine oil quality is the chief factor affecting engine service life. Change the engine oil as specified in the maintenance schedule (page 93).

When running in very dusty conditions, oil changes should be performed more frequently than specified in the maintenance schedule.

Please dispose of used engine oil in a manner that is compatible with the environment. We suggest you take it in a sealed container to your local recycling center or service station for reclamation. Do not throw it in the trash or pour it on the ground or down a drain.

Used engine oil may cause skin cancer if repeatedly left in contact with the skin for prolonged periods. Although this is unlikely unless you handle used oil on a daily basis, it is still advisable to thoroughly wash your hands with soap and water as soon as possible after handling used oil.

Changing the oil filter requires a special oil filter tool and a torque wrench. If you do not have these tools and the necessary skill, we recommend that you have your Honda dealer perform this service.

If a torque wrench is not used for this installation, see your Honda dealer as soon as possible to verify proper assembly.

Change the engine oil with the engine at normal operating temperature and the scooter on its center stand to assure complete and rapid draining.

1. Remove the oil filler cap/dipstick (1) from the right crankcase cover.

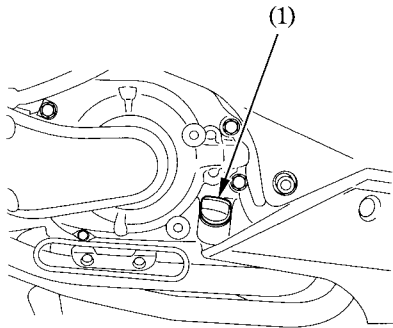

(1) Oil filler cap/dipstick

2. Place a drain pan under the crankcase and remove the oil drain plug (2).

The spring (3), oil strainer screen (4) and O-ring (5) will come out when the drain plug is removed.

3. Clean the oil strainer screen.
4. Check that the oil strainer screen, sealing rubber and drain plug O-ring are in good condition.

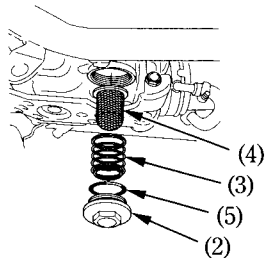

- (2) Oil drain plug
- (3) Spring
- (4) Oil strainer screen
- (5) O-ring

5. Remove the oil filter (6) with a filter wrench and let the remaining oil drain out. Discard the oil filter.

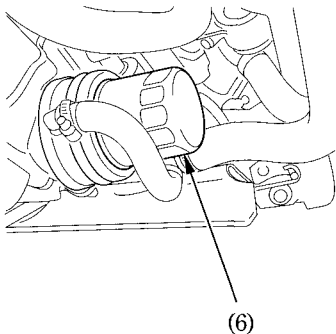

(6) Oil filter

6. Apply a thin coat of engine oil to the new oil filter rubber seal (7).
7. Using a special tool and a torque wrench, install the new oil filter and tighten to a torque of:
26 N·m (2.7 kgf·m , 19 lbf·ft)

Use only the Honda Genuine oil filter or a filter of equivalent quality specified for your model. Using the wrong Honda filter or a non-Honda filter which is not of equivalent quality may cause engine damage.

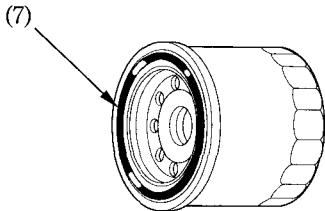

(7) Oil filter rubber seal

8. Install the oil strainer screen, spring and drain plug.

Oil drain plug torque:

15 N·m (1.5 kgf·m , 11 lbf·ft)

9. Fill the crankcase with the recommended grade oil; approximately:

2.2 ℓ (2.3 US qt , 1.9 Imp qt)

10. Install the oil filler cap/dipstick.

11. Start the engine and let it idle for 3–5 minutes.

12. 2–3 minutes after stopping the engine, check that the oil level is at the upper level mark on the oil filler cap/dipstick with the scooter upright on firm, level ground. Make sure there are no oil leaks.

SPARK PLUGS

Refer to the Safety Precautions on page 91 .

Recommended plugs:

CR8EH-9 (NGK) or

U24FER9 (DENSO)

NOTICE

Never use a spark plug with an improper heat range. Severe engine damage could result.

1. Open the seat (page 61).
2. Remove the screws (1).
3. Close the seat.
4. Push the plug maintenance lid (2) backward.

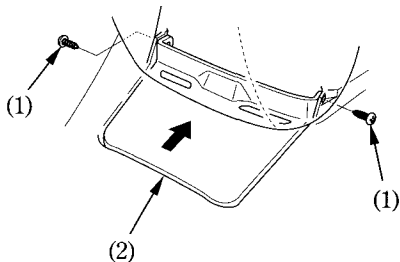

- (1) Screws
(2) Plug maintenance lid

5. Remove the plug maintenance lid (2).

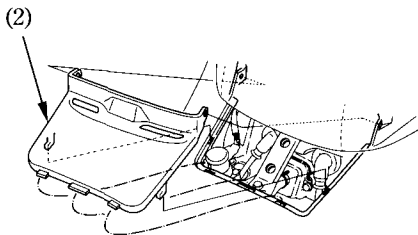

(2) Plug maintenance lid

6. Disconnect the spark plug caps (3) from the spark plugs.

7. Clean any dirt from around the spark plug bases.

Remove the spark plugs using a spark plug wrench (4) furnished in the tool kit.

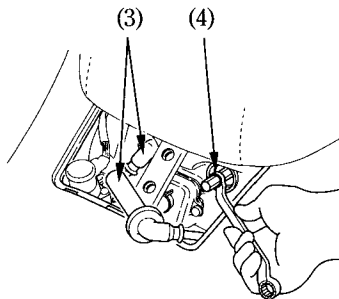

(3) Spark plug caps

(4) Spark plug wrench

8. Discard the spark plug.
9. With the plug washer attached, thread the spark plug in by hand to prevent cross-threading.
10. Tighten each spark plug:
 - If the old plug is good:
1/8 turn after it seats.
 - If installing a new plug, tighten it twice to prevent loosening:
 - a) First, tighten the plug:
NGK: 1/2 turn after it seats.
DENSO: 1 turn after it seats.
 - b) Then loosen the plug.
 - c) Next, tighten the plug again:
1/8 turn after it seats.
11. Reinstall the spark plug caps. Take care to avoid pinching any cables or wires.
12. Install the remaining parts in the reverse order of removal.

NOTICE

Improperly tightened spark plugs can damage the engine. If a plug is too loose, a piston may be damaged. If a plug is too tight, the threads may be damaged.