

HONDA

OWNER'S MANUAL
INSTRUKTIEBOEK
MANUAL DE EXPLICACIONES

NX250

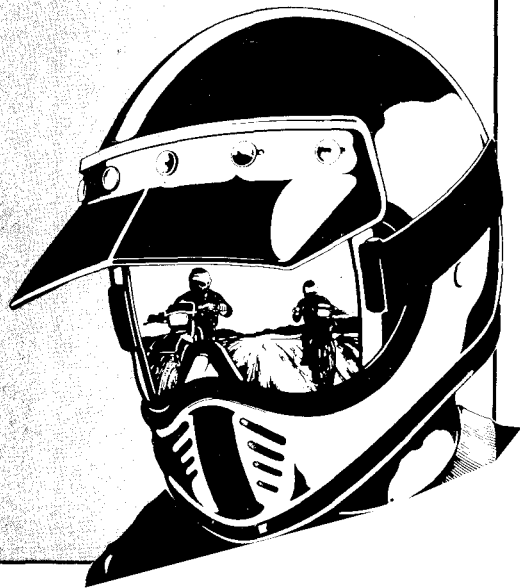

HONDA

NX250

OWNER'S MANUAL

INSTRUKTIEBOEK

MANUAL DE EXPLICACIONES

IMPORTANT NOTICE

- **OPERATOR AND PASSENGER**

This motorcycle is designed to carry the operator and one passenger. Never exceed the maximum weight capacity as shown on the accessories and loading label.

- **ON/OFF-ROAD USE**

This motorcycle is designed for “dual purpose” use.

- **READ THIS OWNER’S MANUAL CAREFULLY**

Pay special attention to statements preceded by the following words:

⚠ WARNING

Indicates a strong possibility of severe personal injury or death if instructions are not followed.

CAUTION:

Indicates a possibility of personal injury or equipment damage if instructions are not followed.

NOTE: Gives helpful information.

This manual should be considered a permanent part of the motorcycle and should remain with the motorcycle when resold.

HONDA NX250 OWNER'S MANUAL

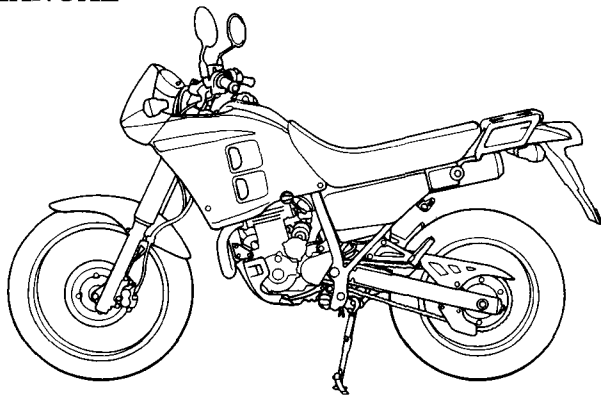

All information in this publication is based on the latest production information available at the time of approval for printing. HONDA MOTOR CO., LTD. reserves the right to make changes at any time without notice and without incurring any obligation.
No part of this publication may be reproduced without written permission.

WELCOME

The motorcycle presents you a challenge to master the machine, a challenge to adventure. You ride through the wind, linked to the road by a vehicle that responds to your commands as no other does. Unlike an automobile, there is no metal cage around you. Like an airplane, a pre-ride inspection and regular maintenance are essential to your safety. Your reward is freedom.

To meet the challenges safely, and to enjoy the adventure fully, you should become thoroughly familiar with this *owner's manual* **BEFORE YOU RIDE THE MOTORCYCLE**.

When service is required, remember that your Honda dealer knows your motorcycle best. If you have the required mechanical “know-how” and tools, your dealer can supply you with an official Honda Service Manual to help you perform many maintenance and repair tasks.

Pleasant riding, and thank you for choosing a Honda.

- Following codes in this manual indicate each country.

F	France	(J) (L)	SP	Spain	(J) (L)
ED	Europe	(J) (L)	FI	Finland	(K) (L)
ND	Northern Europe	(J) (L)	DE	Denmark	(K) (L)
G	Germany	(K) (L)	SD	Sweden	(L)
IIG	Germany	(K) (L)			

*G.....Full power type

*IIG.....Limited power type

- The specifications may vary with each locale.

OPERATION

Page		Page	
1	MOTORCYCLE SAFETY	30	Right Handlebar Controls
1	Safe Riding Rules	31	Left Handlebar Controls
2	Protective Apparel		
3	Modifications	32	FEATURES (Not required for operation)
4	Loading and Accessories	32	Steering Lock
6	Off-Road Safety	33	Helmet Holder
		34	Seat
7	PARTS LOCATION	34	Document Compartment
10	Instruments and Indicators		
		35	OPERATION
13	MAJOR COMPONENTS (Information you need to operate this motorcycle)	35	Pre-ride Inspection
13	Brakes	36	Starting the Engine
17	Clutch	38	Running-in
19	Coolant	39	Riding (F, ED, SP, DE)
22	Fuel	40	Riding (G, IIG, ND, FI)
26	Engine Oil	42	Braking
27	Tyres	43	Parking
		44	Parking the Motorcycle on the Side Stand (G, IIG, ND, FI)
29	ESSENTIAL INDIVIDUAL COMPONENTS	45	Anti-theft Tips
29	Ignition Switch		

MAINTENANCE

Page	
46	MAINTENANCE
47	Maintenance Schedule
49	Tool Kit
50	Serial Numbers
51	Colour Label
51	Maintenance Precautions (F, ED, SP, DE)
52	Maintenance Precautions (G, IIG, ND, FI)
53	Air Cleaner
54	Crankcase Breather
55	Engine Oil
59	Spark Plug
60	Throttle Operation
62	Idle Speed
63	Drive Chain
68	Front Suspension
69	Rear Suspension
70	Side Stand (F, ED, SP, DE)
71	Side Stand (G, IIG, ND, FI)
72	Wheel Removal
76	Brake Pad Wear
77	Brake Shoe Wear

Page	
78	Battery
80	Fuse Replacement
82	Stoplight Switch adjustment

83 CLEANING

84 STORAGE GUIDE

84	Storage
85	Removal from Storage

86 SPECIFICATIONS

MOTORCYCLE SAFETY

▲ WARNING

- * **Motorcycle riding requires special efforts on your part to ensure your safety. Know these requirements before you ride:**

SAFE RIDING RULES

1. Always make a pre-ride inspection (page 35) before you start the engine. You may prevent an accident or equipment damage.
2. Many accidents involve inexperienced riders. Most countries require a special motorcycle riding test or licence. Make sure you are qualified before you ride. **NEVER** lend your motorcycle to an inexperienced rider.
3. Many automobile/motorcycle accidents happen because the automobile driver does not “see” the motorcyclist.
Make yourself conspicuous to help avoid the accident that wasn't your fault:
 - Wear bright or reflective clothing.
 - Don't ride in another motorist's “blind spot.”
4. Obey all national and local laws and regulations.
 - Excessive speed is a factor in many accidents. Obey the speed limits, and **NEVER** travel faster than conditions warrant.
 - Signal before you make a turn or lane change. Your size and maneuverability can surprise other motorists.

5. Don't let other motorists surprise you. Use extra caution at intersections, parking lot entrances and exits, and driveways.
6. Keep both hands on the handlebars and both feet on the footpegs while riding. A passenger should hold on to the motorcycle or the operator with both hands and keep both feet on the passenger footpegs.

PROTECTIVE APPAREL

1. Most motorcycle accident fatalities are due to head injuries: **ALWAYS** wear a helmet. You should also wear a face shield or goggles as well as boots, gloves, and protective clothing. A passenger needs the same protection.
2. The exhaust system becomes hot during operation, and it remains hot for a while after stopping the engine. Be careful not to touch the exhaust system while it is hot. Wear clothing that fully covers your legs.
3. Do not wear loose clothing which could catch on the control levers, footpegs, drive chain or wheels.

MODIFICATIONS

⚠ WARNING

- * **Modification of the motorcycle, or removal of original equipment, may render the vehicle unsafe or illegal. Obey all national and local equipment regulations.**

LOADING AND ACCESSORIES

▲ WARNING

- * **A motorcycle is sensitive to changes in weight distribution. Improper loading of cargo can impair the motorcycle's stability and performance. To prevent an accident, use extreme care when riding with cargo. These general guidelines may help you decide whether or how to equip your motorcycle, and how to load it safely.**

Loading

The combined weight of the rider, passenger and cargo must not exceed the maximum weight capacity:

185 kg (407 lbs)

1. Keep cargo weight low and close to the center of the motorcycle. Load weight equally on both sides to minimize imbalance. As weight is located further from the motorcycle's center of gravity, handling is proportionally affected.
2. All cargo must be secure for stable handling. Recheck cargo security frequently.

3. Do not attach large or heavy items (such as a sleeping bag or tent) to the handlebars, front forks, or fender. Unstable handling or slow steering response may result.

Accessories

You are personally responsible for proper selection, installation, and use of non-Honda accessories. Always follow the guidelines under Loading, and these:

1. Carefully inspect the accessory to make sure it does not obscure lights, reduce ground clearance, or limit suspension travel, steering travel or control operation.
2. Luggage racks are for lightweight items. Bulky items may snag on a tree or other nearby object causing loss of control.
3. Do not add electrical equipment that will exceed the motorcycle's electrical system capacity. An electrical failure could cause a dangerous loss of lights or engine power at night, in traffic or far from help.

OFF-ROAD SAFETY

Learn to ride in an uncongested off-road area free of obstacles before venturing into unfamiliar terrain.

1. Always obey local off-road riding laws and regulations.
2. Obtain permission to ride on private property. Avoid posted areas and obey "No Trespassing" signs.
3. Ride with a friend on another motorcycle so that you can assist each other in case of trouble.
4. Familiarity with your motorcycle is critically important should a problem occur far from help.
5. Never ride beyond your ability and experience or faster than conditions warrant.
6. If you are not familiar with the terrain, ride cautiously. Hidden rocks, holes, or ravines could spell disaster.
7. Spark arresters and mufflers are required in most areas. Don't modify your exhaust system. Remember that excessive noise bothers everyone and creates a bad image for motorcycling.

PARTS LOCATION

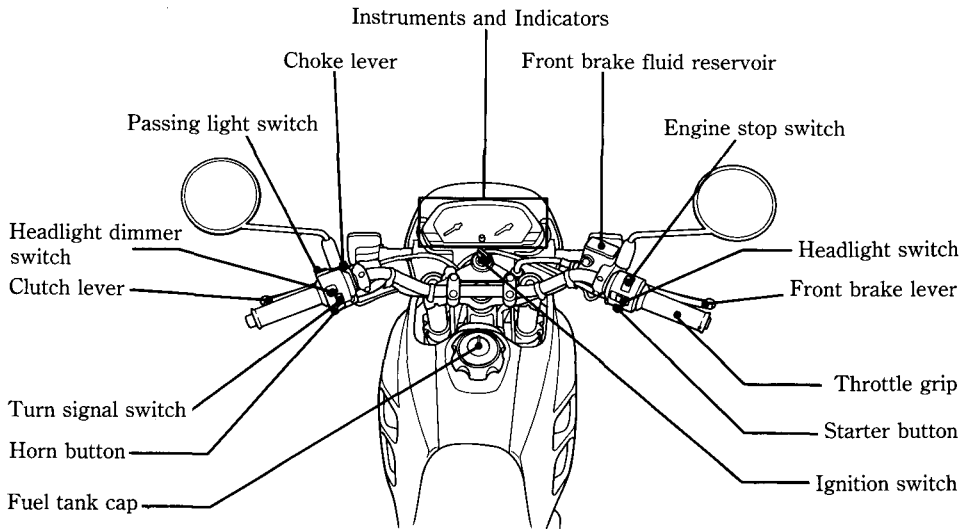

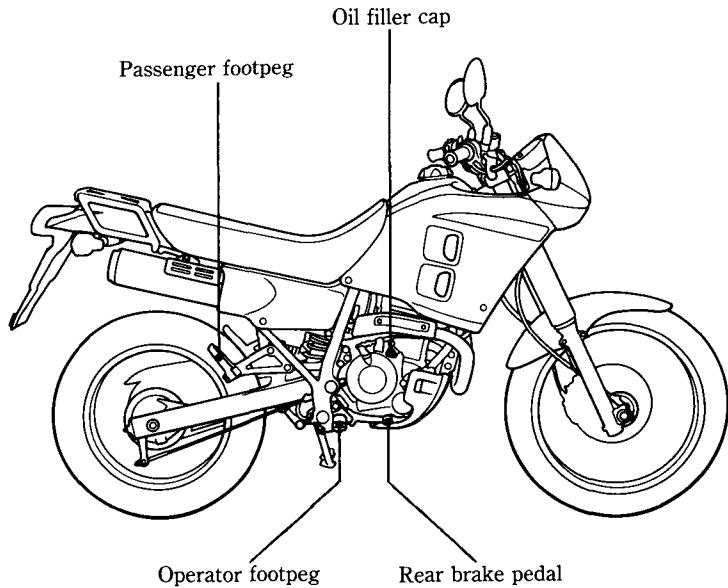

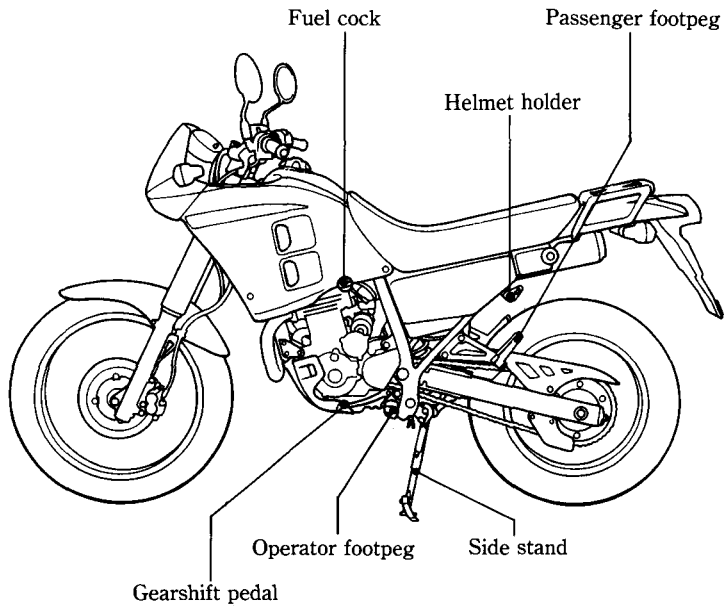

INSTRUMENTS AND INDICATORS

The indicators and warning light are grouped between the instruments. Their functions are described in the tables on the following pages.

- (1) Speedometer
- (2) Odometer
- (3) Neutral indicator
- (4) High beam indicator
- (5) Tachometer
- (6) Tachometer red zone
- (7) Right turn signal indicator
- (8) Coolant temperature warning light
- (9) Tripmeter reset knob
- (10) Tripmeter
- (11) Left turn signal indicator

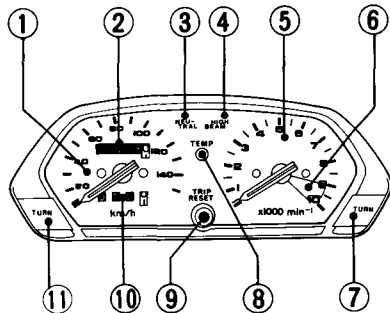

Ref. No.	Description	Function
1	Speedometer	Shows riding speed.
2	Odometer	Shows accumulated mileage.
3	Neutral indicator (green)	Lights when the transmission is in neutral.
4	High beam indicator (blue)	Lights when the headlight is on high beam.
5	Tachometer	Shows engine rpm.
6	Tachometer red zone	Never allow the tachometer needle to enter the red zone, even after the engine has been broken in. CAUTION: * The red zone indicates the maximum limits of engine speed and running the engine in the red zone may adversely affect its service life.
7	Right turn signal indicator (amber) (green: FI type only)	Flashes when the right turn signal operates.

Ref. No.	Description	Function
8	Coolant temperature warning light (red)	<p>Lights when the coolant is over the specified temperature. If the warning light goes on while riding, stop the engine and check the reserve tank coolant level. Read pages 19–21 and do not ride the motorcycle until the problem has been corrected.</p> <p>CAUTION: * Exceeding maximum running temperature may cause serious engine damage.</p>
9	Tripmeter reset knob	Resets tripmeter to zero (0) by pushing the knob.
10	Tripmeter	Shows mileage per trip.
11	Left turn signal indicator (amber) (green: FI type only)	Flashes when the left turn signal operates.

MAJOR COMPONENTS (Information you need to operate this motorcycle)

BRAKES

Front Brake

This motorcycle has a hydraulic disc front brake. As the brake pads wear, brake fluid level drops, automatically compensating for wear.

There are no adjustments to perform, but fluid level and pad wear must be inspected periodically. The system must be inspected frequently to ensure there are no fluid leaks. If the control lever free travel becomes excessive and the brake pads are not worn beyond the recommended limit (page 76), there is probably air in the brake system and it must be bled. See your authorized Honda dealer for this service.

Brake Fluid Level:

WARNING

- * **Brake fluid may cause irritation. Avoid contact with skin or eyes. In case of contact, flush thoroughly with water and call a doctor if your eyes were exposed.**

Check that the fluid level is above the LOWER level mark (5) with the motorcycle in an upright position.

Brake fluid must be added to the reservoir whenever the fluid level begins to reach the LOWER level mark (5).

Remove the screws (1), reservoir cover (2), diaphragm plate (3) and diaphragm (4). Fill the reservoir with DOT 4 BRAKE FLUID from a sealed container up to the upper level mark (6). Reinstall the diaphragm, diaphragm plate and cover. Tighten the screws securely.

CAUTION:

- * **Handle brake fluid with care because it can damage plastic and painted surfaces.**
- * **When adding brake fluid, be sure the reservoir is horizontal before the cap is removed or brake fluid may spill out.**
- * **Use only DOT 4 brake fluid from a sealed container.**
- * **Never allow contaminants such as dirt or water to enter the brake fluid reservoir.**

Other Checks:

Make sure there are no fluid leaks. Check for deterioration or cracks in the hoses and fittings.

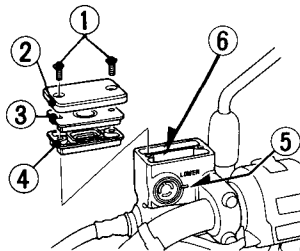

- | | |
|---------------------|----------------------|
| (1) Screws | (4) Diaphragm |
| (2) Reservoir cover | (5) LOWER level mark |
| (3) Diaphragm plate | (6) UPPER level mark |

Rear Brake

Adjustment:

1. Place the motorcycle on its side stand.
2. The stopper bolt (1) is provided to allow adjustment of the pedal height. To adjust the pedal height, loosen the lock nut (2) and turn the stopper bolt. Tighten the lock nut.

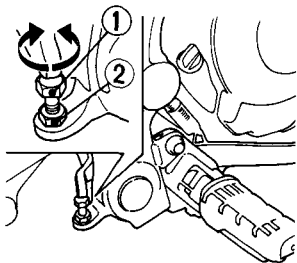

(1) Stopper bolt

(2) Lock nut

3. Measure the distance the rear brake pedal (3) moves before the brake starts to take hold.

Free play should be:

20–30 mm (3/4–1-1/4 in)

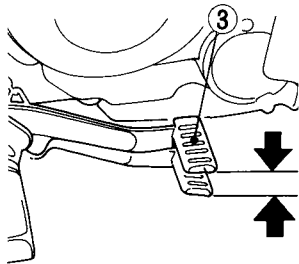

(3) Rear brake pedal

Make free play adjustments by turning the adjusting nut (4) at the brake arm.

NOTE:

- * Make sure the cut-out on the adjusting nut is seated on the brake arm pin (5) after making final free play adjustment.
- * If proper adjustment cannot be obtained by this method, see your authorized Honda dealer.

4. Apply each brake several times and check for free wheel rotation when released.

Other Checks:

Make sure the brake rod, brake arm, spring and fasteners are in good condition.

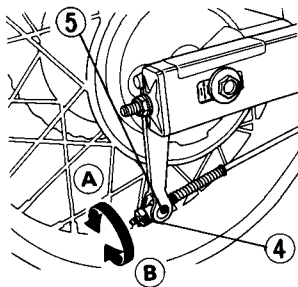

(4) Adjusting nut
(5) Arm pin

(A) Increase free play
(B) Decrease free play

CLUTCH

Clutch adjustment may be required if the motorcycle stalls when shifting into gear or tends to creep; or if the clutch slips, causing acceleration to lag behind engine speed.

Minor adjustments can be made with the clutch cable adjuster (4) at the lever (1).

Normal clutch lever free play is:

10–20 mm (3/8–3/4 in)

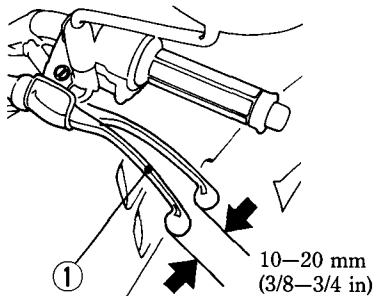

(1) Clutch lever

1. Pull back the rubber dust cover (2). Loosen the lock nut (3) and turn the adjuster (4). Tighten the lock nut (3) and check the adjustment.
2. If the adjuster is threaded out near its limit or if the correct free play cannot be obtained, loosen the lock nut (3) and turn in the cable adjuster (4) completely. Tighten the lock nut (3) and pull on the dust cover.

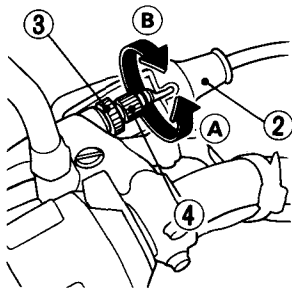

(2) Dust cover

(3) Lock nut

(4) Clutch cable adjuster

(A) Increase free play

(B) Decrease free play

3. At the lower end of the cable, loosen the lock nut (5). Turn the adjusting nut (6) to obtain the specified free play. Tighten the lock nut (5) and check the adjustment.
4. Start the engine, pull in the clutch lever and shift into gear. Make sure the engine does not stall and the motorcycle does not creep. Gradually release the clutch lever and open the throttle. The motorcycle should start smoothly and accelerate gradually.

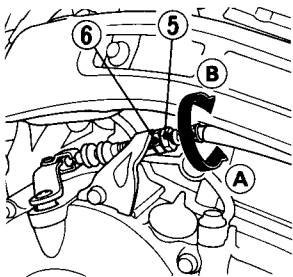

- | | |
|-------------------|------------------------|
| (5) Lock nut | (A) Increase free play |
| (6) Adjusting nut | (B) Decrease free play |

NOTE:

- * If proper adjustment cannot be obtained or the clutch does not work correctly, the cable or clutch friction discs may be worn. Refer to the official Honda service manual or see your authorized Honda dealer.

Other Checks:

Check the clutch cable for kinks or signs of wear that could cause sticking or failure. Lubricate the clutch cable with a commercially available cable lubricant to prevent premature wear and corrosion.

COOLANT

Coolant Recommendation

The owner must properly maintain the coolant to prevent freezing, overheating, and corrosion. Use only high quality ethylene glycol antifreeze containing corrosion protection inhibitors specifically recommended for use in aluminum engines. (SEE ANTIFREEZE CONTAINER LABEL).

CAUTION:

- * **Use only low-mineral drinking water or distilled water as a part of the antifreeze solution. Water that is high in mineral content or salt may be harmful to the aluminum engine.**

The factory provides a 50/50 solution of antifreeze and water in this motorcycle. This coolant solution is recommended for most operating temperatures and provides good corrosion protection. A higher concentration of antifreeze decreases the cooling system performance and is recommended only when additional protection against freezing is needed. A concentration of less than 40/60 (40% antifreeze) will not provide proper corrosion protection. During freezing temperatures, check the cooling system frequently and add higher concentrations of antifreeze (up to a maximum of 60% antifreeze) if required.

Inspection

The reserve tank is behind the left side fairing. Check the coolant level in the reserve tank (1) while the engine is at the normal operating temperature with the motorcycle in an upright position. If the coolant level is below the LOWER level mark (3), remove the radiator grille (4) by removing the bolt (5), remove the reserve tank cap (6) and add coolant mixture until it reaches the UPPER level mark (2). Do not remove the radiator cap.

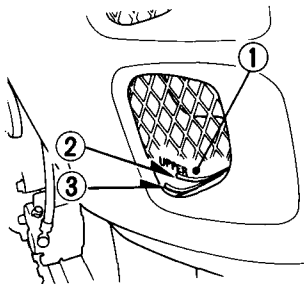

- (1) Reserve tank (3) LOWER level mark
(2) UPPER level mark

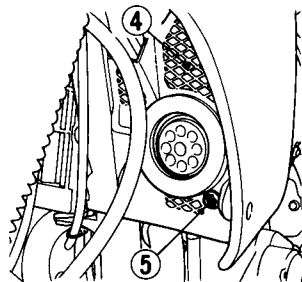

(4) Grille

(5) Bolt

▲ WARNING

- * **Do not remove the radiator cap when the engine is hot. The coolant is under pressure and could scald you.**
- * **Keep hands and clothing away from the cooling fan, as it starts automatically.**

If the reserve tank is empty, or if coolant loss is excessive, check for leaks and see your authorized Honda dealer for repair.

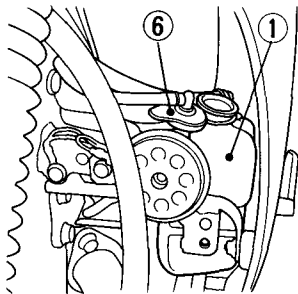

(1) Reserve tank

(6) Cap

FUEL

Fuel Cock

The three way fuel cock (1) is under the left side of the fuel tank.

OFF

With the fuel cock in the OFF position, fuel cannot flow from the tank to the carburetor. Turn the valve off whenever the motorcycle is not in use.

ON

With the fuel cock in the ON position, fuel will flow from the main fuel supply to the carburetor.

RES

With the fuel cock in the RES position, fuel will flow from the reserve fuel supply to the carburetor. Use the reserve fuel only when the main supply is gone. Refill the tank as soon as possible after switching to RES.

The reserve fuel supply is:

2.0 ℓ (0.5 US gal, 0.4 Imp gal)

▲ WARNING

- * **To avoid running out of fuel that may result in a sudden stop, learn how to operate the fuel valve when riding the motorcycle.**
- * **Be careful not to touch any hot engine parts while operating the fuel cock.**

NOTE:

- * Do not operate this motorcycle with the fuel cock in the RES position after refueling. You may run out of fuel with no reserve.

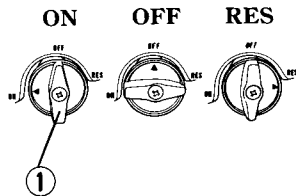

(1) Fuel cock

Fuel Tank

The fuel tank capacity, including reserve, is:

9.0 ℓ (2.4 US gal, 2.0 Imp gal)

To open the fuel tank cap (1), open the tank cap cover (2), insert the ignition key (3) and turn it clockwise. The cap will pop up and can be lifted off.

To close the fuel tank cap, align the latch in the cap with the slot in the filler neck.

Push cap into the filler neck until it snaps closed and locks. Remove the key and close the tank cap cover.

Use unleaded or low-lead petrol with a research octane number of 91 or higher. We recommend that you use unleaded petrol because it produces fewer engine and spark plug deposits and extends the life of exhaust system components.

CAUTION:

* If “spark knock” or “pinking” occurs at a steady engine speed under normal load, change brands of petrol. If spark knock or pinking persists, consult your authorized Honda dealer. Failure to do so is considered misuse, and damage caused by misuse is not covered by Honda’s Limited Warranty.

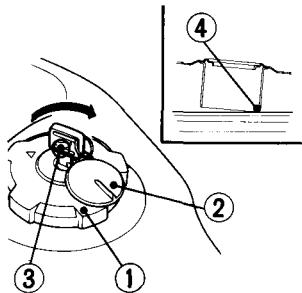

- | | |
|--------------------|------------------|
| (1) Fuel tank cap | (3) Ignition key |
| (2) Tank cap cover | (4) Filler neck |

⚠ WARNING

- * **Petrol is extremely flammable and is explosive under certain conditions. Refuel in a well-ventilated area with the engine stopped. Do not smoke or allow flames or sparks in the area where the engine is refueled or where petrol is stored.**
- * **Do not overfill the tank (there should be no fuel in the filler neck (4)). After refueling, make sure the fuel cap is closed securely.**
- * **Be careful not to spill fuel when refueling. Spilled fuel or fuel vapor may ignite. If any fuel is spilled, make sure the area is dry before starting the engine.**
- * **Avoid repeated or prolonged contact with skin or breathing of vapor. KEEP OUT OF REACH OF CHILDREN.**

Petrol Containing Alcohol

If you decide to use a petrol containing alcohol (gasohol), be sure it's octane rating is at least as high as that recommended by Honda. There are two types of "gasohol": one containing ethanol, and the other containing methanol. Do not use petrol that contains more than 10% ethanol. Do not use petrol containing methanol (methyl or wood alcohol) that does not also contain cosolvents and corrosion inhibitors for methanol. Never use petrol containing more than 5% methanol, even if it has cosolvents and corrosion inhibitors.

NOTE:

- * Fuel system damage or engine performance problem resulting from the use of fuels that contain alcohol is not covered under the warranty. Honda cannot endorse the use of fuels containing methanol since evidence of their suitability is as yet incomplete.

NOTE:

- * Before buying fuel from an unfamiliar station, try to find out the fuel contains alcohol, if it does, confirm the type and percentage of alcohol used. If you notice any undesirable operating symptoms while using a petrol that contains alcohol, or one that you think contains alcohol, switch to a petrol that you know does not contain alcohol.

ENGINE OIL

Engine Oil Level Check

Check the engine oil level each day before riding the motorcycle.

The level must be maintained between the upper (2) and lower (3) level marks on the dipstick (1).

1. Start the engine and let it idle for a few minutes.
2. Stop the engine and hold the motorcycle in an upright position on firm, level ground.
3. After a few minutes, remove the dipstick (1), wipe it clean, and reinsert the dipstick without screwing it in. The oil level should be between the upper (2) and lower (3) marks on the dipstick.
4. If required, remove the oil filler cap and add the specified oil up to the upper level mark (See page 55). Do not overfill.
5. Reinstall the oil filler cap and dipstick. Check for oil leaks.

CAUTION:

- * Running the engine with insufficient oil can cause serious engine damage.

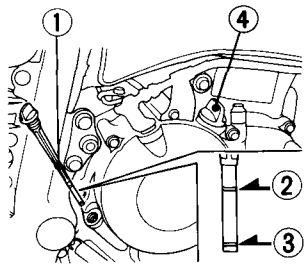

- | | |
|----------------------|----------------------|
| (1) Dipstick | (3) Lower level mark |
| (2) Upper level mark | (4) Filler cap |

TYRES

Proper air pressure will provide maximum stability, riding comfort and tyre life.

Check tyre pressure frequently and adjust if necessary.

NOTE:

* Tyre pressure should be checked before you ride while the tyres are "cold".

On/off-road tyres are standard on this model. Select the right replacement tyre in accordance with the following specifications.

Check the tyre for cuts, imbedded nails or other sharp objects. See your authorized Honda Dealer for replacement of damaged tyre or punctured inner tubes.

		Front	Rear
Tyre size		90/100-19 55P	120/90-16 63P
Cold tyre pressures kPa (kg/cm ² , psi)	Rider only	150 (1.5, 22)	150 (1.5, 22)
	Rider and one passenger	150 (1.5, 22)	175 (1.75, 25)
Tyre brand BRIDGESTONE DUNLOP		TW39 K460	TW40 K460

▲ WARNING

- * **Do not attempt to patch a damaged tyre or inner tube. Wheel balance and tyre reliability may be impaired.**
- * **Improper tyre inflation will cause abnormal tread wear and create a safety hazard. Underinflation may result in the tyre slipping on, or coming off of the rims, causing tyre deflation that may result in a loss of vehicle control.**
- * **Operation with excessively worn tyre is hazardous and will adversely affect traction and handling.**
- * **The use of tyres other than those listed on the tyre information label may adversely affect handling.**
- * **Maintenance of spoke tension and wheel trueness are critical to safe motorcycle operation. During the first 1000 km (600 miles) spokes will loosen more rapidly due to initial seating of parts. Excessively loose spokes may result in high speed instability and possible loss of control.**

Replace tyre before tread depth at the center of the tyre reaches the following limit:

Minimum tread depth	
Front:	1.5 mm (0.06 in)
Rear:	2.0 mm (0.08 in)

ESSENTIAL INDIVIDUAL COMPONENTS

IGNITION SWITCH

The ignition switch (1) is directly below the indicator panel.

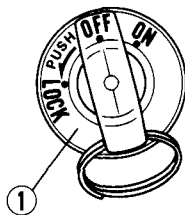

(F, ED, ND, G)
(IIG, SP, FI)

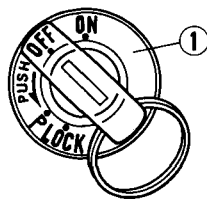

(DE)

(1) Ignition switch

Key Position	Function	Key Removal
LOCK (steering lock)	Steering is locked. Engine and lights cannot be operated.	Key can be removed.
P (parking) (DE)	For parking the motorcycle near traffic. The taillight and position light are on, but all other lights are off. The engine cannot be started.	Key can be removed.
OFF	Engine and lights cannot be operated.	Key can be removed.
ON	The lights can be operated. The engine can be started.	Key cannot be removed.

RIGHT HANDLEBAR CONTROLS

Engine Stop Switch

The engine stop switch (1) is next to the throttle grip. When the switch is in the RUN position, the engine will operate. When the switch is in the OFF position, the engine will not operate. This switch is intended primarily as a safety or emergency switch and should normally remain in the RUN position.

Headlight Switch

The headlight switch (3) has three positions, "H", "P" and "OFF" marked by a red dot.

H: Headlight, taillight, position light and meter lights on.

P: Position light, taillight and meter lights on.

OFF (dot): Headlight, taillight, position light and meter lights off.

Starter Button

The starter button (2) is below the headlight switch (3).

When you press in the button, the starter cranks the engine.

See pages 36—37 for "Starting Procedure."

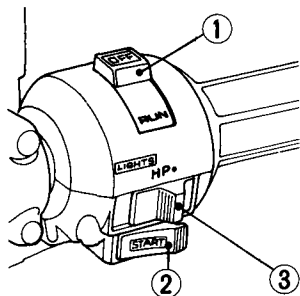

(1) Engine stop switch (3) Headlight switch
(2) Starter button

LEFT HANDLEBAR CONTROLS

Headlight Dimmer Switch (1)

Push the dimmer switch to “HI” to select high beam or to “LO” to select low beam.

Passing Light Control Switch (2)

When this switch is pressed, the headlight flashes on to signal approaching cars or when passing.

Turn Signal Switch (3)

Move to L to signal a left turn, R to signal a right turn. Press to turn signal off.

Horn Button (4)

Press the button to sound the horn.

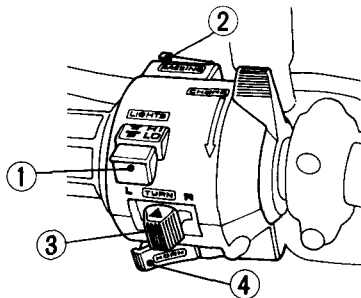

- (1) Headlight dimmer switch
- (2) Passing light control switch
- (3) Turn signal switch
- (4) Horn button

FEATURES (Not required for operation)

STEERING LOCK

To lock the steering, turn the handlebars all the way to the left or right, turn the key (1) to LOCK while pushing in. Remove the key.

▲ WARNING

- * **Do not turn the key to LOCK while riding the motorcycle; loss of vehicle control may result.**

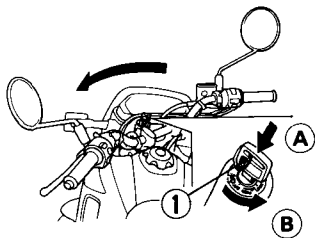

(1) Ignition key

(A) Push in

(B) Turn to LOCK

HELMET HOLDER

The helmet holder (1) is on the left side below the seat. Insert the ignition key (2) and turn it counterclockwise to unlock the holder. Hang your helmet on the holder pin (3) and push in the holder pin. Then remove the key.

▲ WARNING

* **The helmet holder is designed for helmet security while parked. Do not ride with a helmet attached to the holder; the helmet may interfere with safe operation and result in loss of control.**

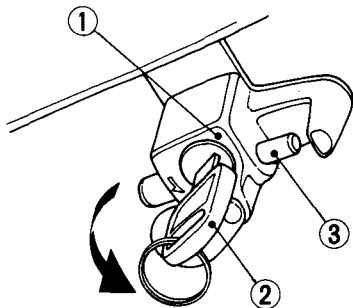

(1) Helmet holder
(2) Ignition key

(3) Holder pin

SEAT

To remove the seat (1), insert the ignition key (2) into the lock (3) and turn it clockwise to unlock the seat.

Remove the seat.

To install the seat, insert the seat tab under the frame cross member and push down on the rear of the seat..

CAUTION:

* **Be sure the seat is locked securely in position after installation.**

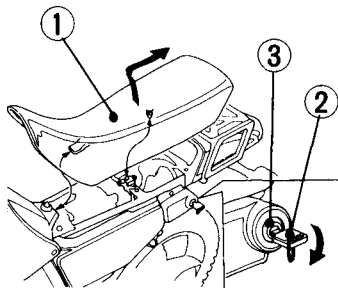

(1) Seat

(2) Ignition key

34

(3) Lock

DOCUMENT COMPARTMENT

The document compartment (1) is under the seat.

This owner's manual and other documents should be stored in the vinyl bag. When washing your motorcycle, be careful not to flood this area with water.

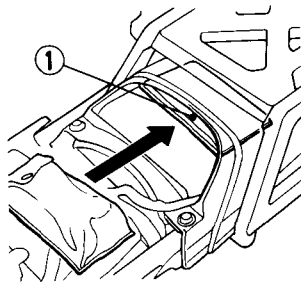

(1) Document compartment

OPERATION

PRE-RIDE INSPECTION

▲ WARNING

- * If the Pre-ride Inspection is not performed, severe personal injury or vehicle damage may result.**

Inspect your motorcycle every day before you ride it. The items listed here will only take a few minutes to inspect, and in the long run they can save time, expense, and possibly your life.

1. Engine oil level—add engine oil if required (page 26). Check for leaks.
2. Fuel level—fill fuel tank when necessary (page 23). Check for leaks.
3. Coolant level—add coolant if required. Check for leaks (pages 19–21).
4. Front and rear brakes—check operation; make sure there is no brake fluid leakage. Adjust free play if necessary (pages 13–16).
5. Tyres—check condition and pressure (pages 27–28).
6. Drive chain—check condition and slack (pages 63–67). Adjust and lubricate if necessary.

7. Throttle—check for smooth opening and closing in all steering positions.
8. Lights and horn—check that headlight, tail/stoplight, turn signals, indicators and horn function properly.
9. Engine stop switch—check for proper function (page 30).
10. Side stand (F, ED, SP, DE)—check for proper function (page 70).

Correct any discrepancy before you ride. Contact your authorized Honda dealer for assistance if you cannot correct the problem.

STARTING THE ENGINE

NOTE:

- * The electric system is designed to prevent electric starting if the transmission is in gear, unless the clutch is disengaged. However, it is recommended that the transmission be placed in neutral before attempting to start the engine.

▲ WARNING

- * **Exhaust gases contain poisonous carbon monoxide gas that can cause loss of consciousness and lead to death. Never run the engine in a closed garage or confined area.**

Preparation

1. Make sure the transmission is in neutral and the fuel cock is ON.
2. Insert the key in the ignition switch and turn to ON. The neutral indicator (green) should go on.
3. Make sure the engine stop switch is in RUN.

Starting Procedure

1. Pull the choke lever (1) back all the way to the fully closed position (A), if the engine is cold.
2. Press the starter button, leaving the throttle closed.
3. Warm up the engine by opening and closing the throttle until it runs smoothly, with the choke open (B).

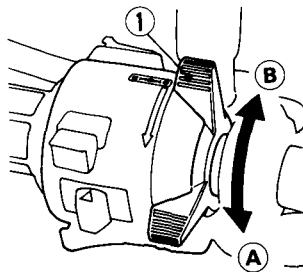

(1) Choke lever

NOTE:

- * Do not use the electric starter for more than 5 seconds at a time. Release the starter button for approximately 10 seconds before pressing it again.

Flooded Engine

If the engine fails to start after repeated attempts, it may be flooded with excess fuel. To clear a flooded engine, turn the engine stop switch OFF and push the choke lever forward to Fully Open (B). Open the throttle fully and crank the engine for 5 seconds. Wait 10 seconds, then turn the engine stop switch ON and follow the Starting Procedure (page 36).

RUNNING-IN

During initial running-in, newly machined surfaces will be in contact with each other and these surfaces will wear in quickly. Running-in maintenance at 1,000 km (600 miles) is designed to compensate for this initial minor wear. Timely performance of running-in maintenance will ensure optimum service life and performance from the engine.

The general rules are as follows:

1. Never labour the engine with full throttle at low engine speeds. This rule is applicable not only during running-in but at all times.
2. Maximum continuous engine speed during the first 1,000 km (600 miles) must not exceed $5,000 \text{ min}^{-1}$ (rpm).

CAUTION:

- * **The red zone indicates the maximum limits of engine speed and running the engine in the red zone will adversely affect its service life.**

RIDING (F, ED, SP, DE)

▲ WARNING

- * **Review Motorcycle Safety (pages 1—6) before you ride.**
- * **Make sure the side stand is fully retracted before riding the motorcycle.**

NOTE:

- * Make sure the function of the side stand mechanism. (See MAINTENANCE SCHEDULE on page 47 and explanation for SIDE STAND on page 70.)
1. Warm up the engine.
 2. With the engine idling, squeeze the clutch lever and shift into low (1st) by depressing the gearshift pedal.
 3. Slowly release the clutch lever while gradually increasing speed. Coordination of these two operations will assure a smooth start.
 4. When the motorcycle attains smooth forward motion, slow down the engine, squeeze the clutch lever again and shift into 2nd by raising the shift pedal. Do the same for the other gears.

5. Coordinate the throttle and brakes for smooth deceleration.
6. Both front and rear brakes should be used at the same time and should not be applied strongly enough to lock the wheel, or braking effectiveness will be reduced and control of the motorcycle be difficult.

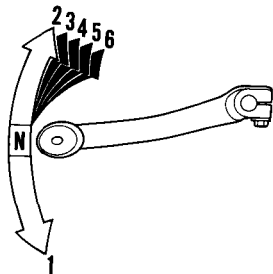

RIDING (G, IIG, ND, FI)

The side stand (1) is designed to retract automatically when the motorcycle is raised to an upright position.

▲ WARNING

- * Review Motorcycle Safety (pages 1—6) before you ride.
- * Make sure the side stand has fully retracted before riding the motorcycle. If not retracted, the side stand may cause an accident.
- * When the side stand is retracting, be careful to keep your leg out of its path. The side stand is spring-loaded and can cause injury if it hits you.

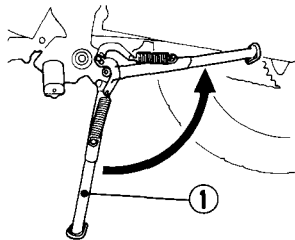

(1) Side Stand

NOTE:

* Make sure the function of the side stand mechanism. (See MAINTENANCE SCHEDULE on page 47 and explanation for SIDE STAND on page 71).

1. After the engine has been warmed up, the motorcycle is ready for riding.
2. While the engine is idling, pull in the clutch lever and depress the gearshift pedal to shift into 1st (low) gear.
3. Slowly release the clutch lever and at the same time gradually increase engine speed by opening the throttle. Coordination of the throttle and clutch lever will assure a smooth positive start.
4. When the motorcycle attains a moderate speed, close the throttle, pull in the clutch lever and shift to 2nd gear by raising the gearshift pedal.
5. This sequence is repeated to progressively shift to 3rd, 4th, 5th and 6th (top) gear.

6. Raise the pedal to shift to a higher gear and depress the pedal to down shift. Each stroke of the pedal engages the next gear in sequence. The pedal automatically returns to the horizontal position when released.

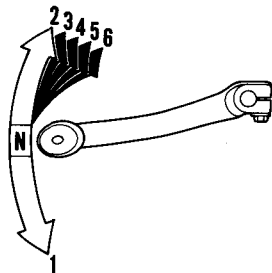

BRAKING

1. For normal braking, gradually apply both front and rear brakes while downshifting to suit your road speed.
2. For maximum deceleration, close the throttle and apply the front and rear brakes firmly. Disengage the clutch before the motorcycle stops.

WARNING

- * **Independent use of only the front or rear brake reduces stopping performance. Extreme braking may cause either wheel to lock, reducing control of the motorcycle.**
- * **When possible, reduce speed or brake before entering a turn; closing the throttle or braking in mid-turn may cause wheel slip. Wheel slip will reduce control of the motorcycle.**

- * **When riding in wet or rainy conditions, or on loose surfaces, the ability to maneuver and stop will be reduced. All of your actions should be smooth under these conditions. Sudden acceleration, braking or turning may cause loss of control. For your safety, exercise extreme caution when braking, accelerating or turning.**
- * **When descending a long, steep grade, use engine compression braking by downshifting, with intermittent use of both brakes. Continuous brake application can overheat the brakes and reduce their effectiveness.**
- * **Do not ride the brakes. In other words, don't operate the brake pedal unless you intend to brake. This causes excessive brake wear and can damage, or lead to loss of the brakes through overheating. Your brake light may also confuse other drivers.**

PARKING

1. After stopping the motorcycle, shift the transmission into neutral, turn the fuel cock OFF, turn the handlebar all the way to the left, turn the ignition switch OFF and remove the key.
2. Use the side stand to support the motorcycle while parked.

CAUTION:

- * **Park the motorcycle on firm, level ground to prevent it from falling over.**
 - * **If you park on a slight incline, aim the front of the motorcycle uphill to reduce the possibility of rolling off the side stand or overturning.**
3. Lock the steering to help prevent theft (page 32).

PARKING THE MOTORCYCLE ON THE SIDE STAND (G, IIG, ND, FI)

Observe the following sequence:

- Turn off the engine.
- Get off the motorcycle to the left side, holding the vehicle in an upright position.
- Turn the handlebars fully to the left.
- Swing the side stand (1) down against the spring tension as far as it will go, and hold it in that position with your foot.
- Lean the motorcycle slowly to the left until it rests on the side stand.

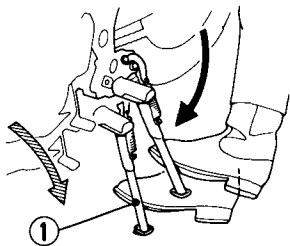

(1) Side Stand

CAUTION:

- * **This side stand is designed to retract even if the motorcycle is raised only partially. Be sure to remember this, when you use the side stand.**

Instructions

- Be sure the side stand is pushed down to its furthest possible position before you apply weight to it.
- Select a flat surface for parking. If possible park the motorcycle on incline with its front end pointing uphill. If necessary, place the transmission in first gear to prevent the motorcycle from rolling away.
- Use the side stand only on firm ground.
- Avoid parking the motorcycle in locations near heavy pedestrian traffic.

▲ WARNING

- * **Do not operate the side stand while sitting on the motorcycle. It is difficult to erect the side stand fully while sitting on the motorcycle, and you may fall.**

ANTI-THEFT TIPS

1. Always lock the steering and never leave the key in the ignition switch. This sounds simple but people do forget.
2. Be sure the registration information for your motorcycle is accurate and current.
3. Park your motorcycle in a locked garage whenever possible.
4. Use an additional anti-theft device of good quality.
5. Put your name, address, and phone number in this Owner's Manual and keep it on your motorcycle at all times. Many times stolen motorcycles are identified by information in the Owner's Manuals that are still with them.

NAME: _____

ADDRESS: _____

PHONE NO.: _____

MAINTENANCE

- When service is required, remember that your authorized Honda dealer knows your motorcycle best and is fully equipped to maintain and repair it. The scheduled maintenance may also be performed by a qualified service facility that normally does this kind of work; or you may perform most of the work yourself if you are mechanically qualified and have the proper tools and service data.
- These instructions are based on the assumption that the motorcycle will be used exclusively for its designed purpose. Sustained high speed operation, or operation in unusually wet or dusty conditions, will require more frequent service than specified in the MAINTENANCE SCHEDULE. Consult your authorized Honda dealer for recommendations applicable to your individual needs and use.

MAINTENANCE SCHEDULE

The following items require some mechanical knowledge. Certain items (particularly those marked * and **) may require more technical information and tools. Consult your authorized Honda Dealer. Perform the Pre-ride Inspection (page 35) at each scheduled maintenance period.

I: INSPECT AND CLEAN, ADJUST, LUBRICATE OR REPLACE IF NECESSARY

C: CLEAN R: REPLACE A: ADJUST L: LUBRICATE

ITEM	FREQUENCY	WHICHEVER →		ODOMETER READING [NOTE (1)]							REFER TO PAGE
		COMES FIRST ↓	x 1,000 km	1	6	12	18	24	30	36	
			x 1,000 mi	0.6	4	8	12	16	20	24	
		NOTE	MONTH		6	12	18	24	30	36	
* FUEL LINE					I		I		I	—	
* FUEL STRAINER SCREEN				C	C	C	C	C	C	—	
* THROTTLE OPERATION					I		I		I	60, 61	
* CARBURETOR CHOKE					I		I		I	—	
AIR CLEANER	(NOTE 2)					R			R	53	
CRANKCASE BREATHER	(NOTE 3)				C	C	C	C	C	54	
SPARK PLUG					I	R	I	R	I	59, 60	
* VALVE CLEARANCE				I					I	—	
ENGINE OIL				R		R		R	R	55–58	
ENGINE OIL FILTER				R		R		R	R	56–58	
* CARBURETOR IDLE SPEED				I	I	I	I	I	I	62	
RADIATOR COOLANT	(NOTE 5)					I		I	R	19–21	
* COOLING SYSTEM						I		I	I	—	

ITEM	FREQUENCY	WHICHEVER → COMES FIRST ↓ NOTE	ODOMETER READING [NOTE (1)]							REFER TO PAGE	
			x 1,000 km	1	6	12	18	24	30		36
			x 1,000 mi	0.6	4	8	12	16	20		24
		MONTH		6	12	18	24	30	36		
DRIVE CHAIN		(NOTE 4)		EVERY 1,000 km (600 mi) I, L							63, 64, 67
DRIVE CHAIN SLIDER				I	I	I	I	I	I	64	
BRAKE FLUID		(NOTE 5)		I	I	R	I	I	R	13, 14	
BRAKE SHOE/PADS WEAR				I	I	I	I	I	I	76, 77	
BRAKE SYSTEM			I		I		I		I	13—16, 76, 77	
* BRAKE LIGHT SWITCH					I		I		I	81, 82	
* HEADLIGHT AIM					I		I		I	—	
CLUTCH SYSTEM			I	I	I	I	I	I	I	17, 18	
SIDE STAND					I		I		I	70, 71	
* SUSPENSION					I		I		I	—	
* NUTS, BOLTS, FASTENERS		(NOTE 4)	I		I		I		I	—	
** WHEELS/TYRES		(NOTE 4)	I	I	I	I	I	I	I	—	
** STEERING HEAD BEARINGS			I		I		I		I	—	

* Should be serviced by an authorized HONDA dealer, unless the owner has proper tools and service data and is mechanically qualified. Refer to the official HONDA service manual.

** In the interest of safety, we recommend these items be serviced ONLY by an authorized HONDA dealer.

NOTES:

1. At higher odometer reading, repeat at the frequency interval established here.
2. Service more frequently when riding in unusually wet or dusty areas.
3. Service more frequently when riding in rain or at full throttle.
4. Service more frequently when riding OFF-ROAD.
5. Replace every 2 years, or at indicated odometer interval, whichever comes first. Replacement requires mechanical skill.

TOOL KIT

The tool kit (1) is in the tool compartment under the seat. Some roadside repairs, minor adjustments and parts replacement can be performed with the tools contained in the kit.

- 8 x 12 mm Open end wrench
- 10 x 12 mm Open end wrench
- 14 x 17 mm Open end wrench
- 17 mm Box end wrench
- 24 mm Box end wrench
- Breaker bar
- Spark plug wrench
- 4 mm Hex wrench
- 5 mm Hex wrench
- 6 mm Hex wrench
- Pliers
- Standard/Phillips screwdriver
- No. 3 Phillips screwdriver
- Screwdriver handle
- Fuse remover
- Tool bag

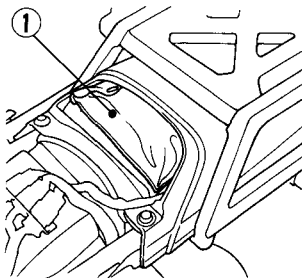

(1) Tool kit

SERIAL NUMBERS

The frame and engine serial numbers are required when registering your motorcycle. They may also be required by your dealer when ordering replacement parts.

Record the numbers here for your reference.

The frame number (1) is stamped on the right side of the steering head.

The engine number (2) is stamped on the right side of the crankcase.

FRAME NO. _____

ENGINE NO. _____

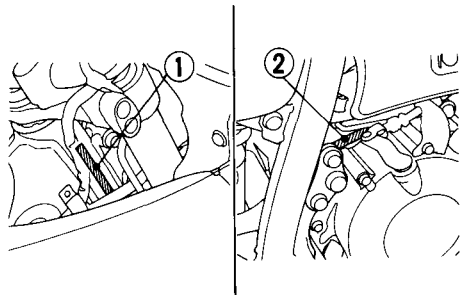

(1) Frame number

(2) Engine number

COLOUR LABEL

The colour label (1) is attached to the frame. It is helpful when ordering replacement parts. Record the colour and code here for your reference.

COLOUR _____

CODE _____

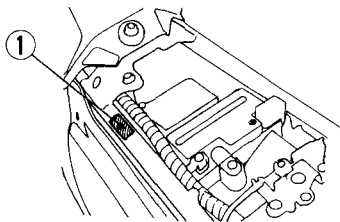

(1) Colour label

MAINTENANCE PRECAUTIONS (F, ED, SP, DE)

▲ WARNING

- * If your motorcycle is overturned or involved in a collision, inspect control levers, cable, brake hoses, caliper, accessories, and other vital parts for damage. Do not ride the motorcycle if damage impairs safe operation. Have your authorized Honda dealer inspect the major components, including frame, suspension and steering parts, for misalignment and damage that you may not be able to detect.
- * Stop the engine and support the motorcycle securely on a firm, level surface before performing any maintenance.
- * Use new, genuine Honda parts or their equivalent for maintenance and repair. Parts which are not of equivalent quality may impair the safety of your motorcycle.

MAINTENANCE PRECAUTIONS **(G, IIG, ND, FI)**

▲ WARNING

- * **If your motorcycle is overturned or involved in a collision, inspect control levers, cable, brake hoses, caliper, accessories, and other vital parts for damage. Do not ride the motorcycle if damage impairs safe operation. Have your authorized Honda dealer inspect the major components, including frame, suspension and steering parts, for misalignment and damage that you may not be able to detect.**
- * **Stop the engine and support the motorcycle securely on a firm, level surface before performing any maintenance.**
- * **Use new, genuine Honda parts or their equivalent for maintenance and repair. Parts which are not of equivalent quality may impair the safety of your motorcycle.**

CAUTION:

- * **Do not use the side stand to support the motorcycle when performing maintenance; it may inadvertently retract, causing the motorcycle to fall over. Be sure to support the motorcycle securely whenever performing motorcycle maintenance.**

AIR CLEANER

(Refer to the maintenance precautions on page 51, 52).

The air cleaner should be serviced at regular intervals (page 47). Service more frequently when riding in unusually wet or dust areas.

1. Remove the seat (page 34).
2. Remove the left side cover (1) by removing the bolts (2).

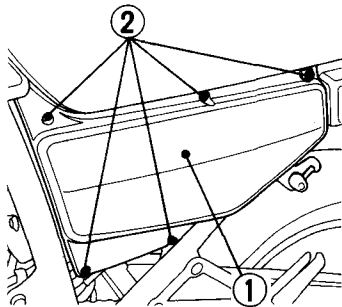

- (1) Left side cover
- (2) Bolts

3. Remove the screws (3).
4. Remove and discard the air cleaner element (4).
5. Install the new air cleaner element.
6. Install the removed parts in the reverse order of removal.

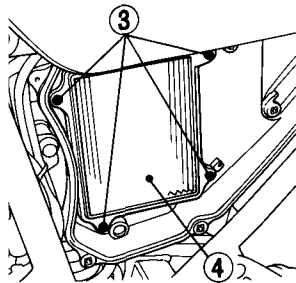

- (3) Screws
- (4) Air cleaner element

CRANKCASE BREATHER

(Refer to the maintenance precaution on page 51, 52).

1. Remove the drain plug (1) from the tube and drain deposits.
2. Reinstall the drain plug.

NOTE:

- * Service more frequently when ridden in rain, at full throttle, or after the motorcycle is washed or overturned. Service if the deposit level can be seen in the transparent section of the drain tube.

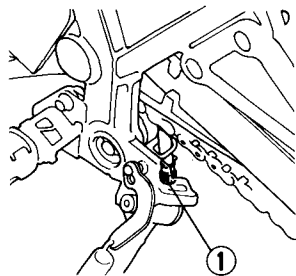

(1) Drain plug

ENGINE OIL

(Refer to the maintenance precautions on page 51, 52).

Engine Oil

Good engine oil has many desirable qualities. Use only high detergent, quality motor oil certified on the container to meet or exceed requirements for service SE, SF or SG.

Viscosity:

Viscosity grade of engine oil should be based on average atmospheric temperature in your riding area. The following provides a guide to the selection of the proper grade or viscosity of oil to be used at various atmospheric temperatures.

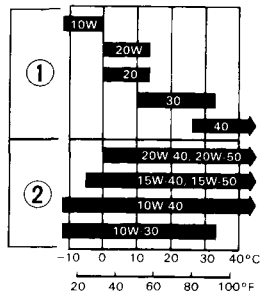

(1) Single grade

(2) Multigrade

Engine Oil and Filter

Engine oil quality is the chief factor affecting engine service life. Change the engine oil as specified in the maintenance schedule (page 47).

NOTE:

- * Change the engine oil with the engine at normal operating temperature and the motorcycle on its side stand to assure complete and rapid draining.
1. To drain the oil, remove the oil filler cap and oil drain plug (1) and sealing washer (2).

▲ WARNING

- * **A warmed-up engine and the oil in it are hot; be careful not to burn yourself.**

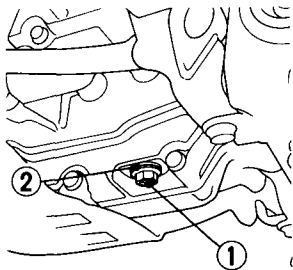

- (1) Drain plug
- (2) Sealing washer

- Remove the two bolts (3) securing the cover (4).
Remove the oil filter element (5).
- Check that the O-ring (6) on the oil filter cover is in good condition.

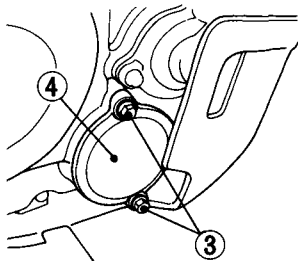

(3) Bolts

(4) Cover

- Insert a new oil filter element. Check that all parts are installed as shown.

CAUTION:

- * **Install the oil filter so that the rubber seal is positioned on the boss of the oil filter cover.**

Install the oil filter cover.

Oil Filter Cover Bolt Torque:

9 N·m (0.9 kg·m, 7 ft·lb)

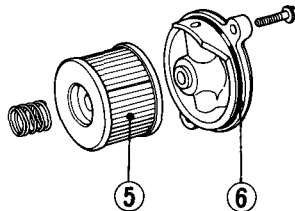

(5) Oil filter element

(6) O-ring

5. Check that the sealing washer on the drain plug is in good condition and install the plug.
Oil Drain Plug Torque:
25 N·m (2.5 kg·m, 18 ft·lb)
6. Fill the crankcase with the recommended grade oil; approximately:
1.35 ℓ (1.43 US qt, 1.19 Imp qt)
7. Install the oil filler cap.
8. Start the engine and let it idle for a 2–3 minutes.
9. Stop the engine and check that the oil level is at the upper level mark on the dipstick with the motorcycle upright on firm, level ground. Make sure there are no oil leaks.

NOTE:

- * Please dispose of used engine oil in a manner that is compatible with the environment. We suggest you take it in a sealed container to your local service station for reclamation. Do not throw it in the rubbish or pour it on the ground.

CAUTION:

- * **Used engine oil may cause skin cancer if repeatedly left in contact with the skin for prolonged periods. Although this is unlikely unless you handle used oil on a daily basis, it is still advisable to thoroughly wash your hands with soap and water as soon as possible after handling used oil.**

SPARK PLUG

(Refer to the maintenance precautions on page 51, 52).

Recommended plug:

CR9EH-9 (NGK), U27FER-9 (ND)

1. Disconnect the spark plug cap from the spark plug.
2. Clean any dirt from around the spark plug base. Remove the spark plug using the plug wrench furnished in the tool kit.

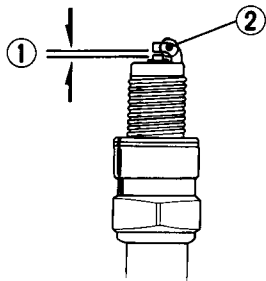

(1) Spark plug gap (2) Side electrode

3. Inspect the electrodes and center porcelain for deposits, erosion or carbon fouling. If the erosion or deposit is heavy, replace the plug. Clean a carbon or wet-fouled plug with a plug cleaner, otherwise use a wire brush.
4. Check the spark plug gap (1) using a wire-type feeler gauge. If adjustment is necessary, bend the side electrode (2) carefully.
The gap should be:
0.8—0.9 mm (0.031—0.035 in)
Make sure the plug washer is in good condition.

5. With the plug washer attached, thread the spark plug in by hand to prevent cross-threading.
6. Tighten a new spark plug 1/2 turn with a spark plug wrench to compress the washer. If you are reusing a plug, it should only take 1/8–1/4 turn after the plug seat.
7. Reinstall the spark plug cap.

CAUTION:

- * **The spark plug must be securely tightened. An improperly tightened plug can become very hot and possibly damage the engine.**
- * **Never use a spark plug with an improper heat range. Severe engine damage could result.**

THROTTLE OPERATION

(Refer to the maintenance precautions on page 51, 52).

Cable Inspection:

Check for smooth rotation of the throttle grip from the fully closed to the fully open position. Check at full left full right steering positions. Inspect the condition of the throttle cables from the throttle grip down to the carburetor. If the cables are kinked, chafed or improperly routed, they should be replaced or rerouted. Recheck cables for tension or stress at both full left and right steering positions.

Lubricate the throttle cables with a commercial-available cable lubricant to prevent premature wear and corrosion.

▲ WARNING

- * **For safe operation and positive engine response, the throttle cables must be properly adjusted.**

Free Play Adjustment:

Measure the throttle grip free play at the throttle grip flange.

The standard free play should be approx:

2–6 mm (1/8–1/4 in)

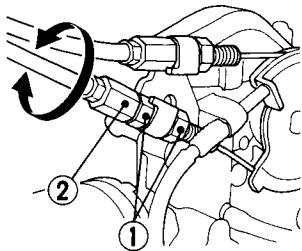

(1) Lock nut

(2) Lower adjuster

Major free play adjustments are made with the lower adjuster (2) (such as after replacing the throttle cables or removing the carburetor). Minor free play adjustments are made with the upper adjuster (4). To adjust free play, loosen the lock nut, (1) or (3), and turn the adjuster, (2) or (4). Tighten the lock nut after making the adjustment.

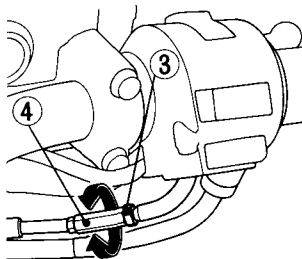

(3) Lock nut

(4) Upper Adjuster

DRIVE CHAIN

(Refer to the maintenance precautions on page 51, 52).

The service life of the drive chain is dependent upon proper lubrication and adjustment. Poor maintenance can cause premature wear or damage to the drive chain and sprockets.

The drive chain should be checked and lubricated as part of the Pre-ride Inspection (page 35). Under severe usage, or when the motorcycle is ridden in unusually dusty areas, more frequent maintenance will be necessary.

Inspection :

1. Turn the engine off, raise the rear wheel off the ground by placing a support under the engine, and shift the transmission into neutral.
2. Check slack in the lower drive chain run midway between the sprockets.

Drive chain slack should be adjusted to allow the following vertical movement by hand:

25–35 mm (1–1-3/8 in)

Move the motorcycle forward to rotate the rear wheel and check drive chain slack as the wheel turns.

Drive chain slack should remain constant as the wheel rotates. If the chain is slack only in certain sections, some links are kinked and binding. Binding can frequently be eliminated by lubrication.

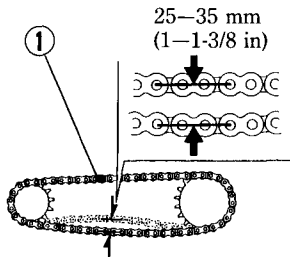

(1) Drive chain

3. Check the chain slider (2) for wear. If the thickness is 3 mm (1/8 in) or less, the chain slider must be replaced.
4. Rotate the rear wheel slowly and inspect the drive chain and sprockets for any of the following conditions:

DRIVE CHAIN

- * Damaged Rollers
- * Loose Pins
- * Dry or Rusted Links
- * Kinked or Binding Links
- * Excessive Wear
- * Improper Adjustment
- * Missing O-rings

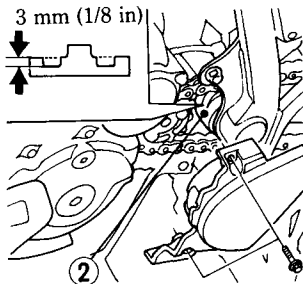

(2) Chain slider

SPROCKETS

- * Excessively Worn Teeth
- * Broken or Damaged Teeth

A drive chain with damaged rollers, loose pins, or missing O-rings must be replaced. A chain which appears dry, or shows signs of rust, requires supplementary lubrication. Kinked or binding links should be thoroughly lubricated and worked free. If links cannot be freed, the chain must be replaced.

Damaged Sprocket Teeth Worn Sprocket Teeth

REPLACE



Normal Sprocket Teeth

GOOD

Adjustment:

Drive chain slack should be checked and adjusted, if necessary, every 1,000 km (600 miles). When operated at sustained high speeds or under conditions of frequent rapid acceleration, the chain may require more frequent adjustment.

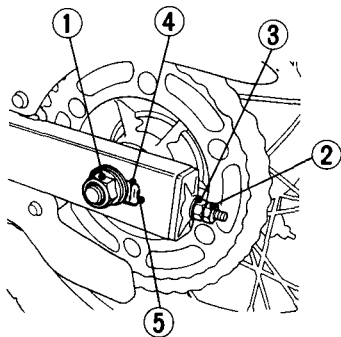

- | | |
|----------------------------------|------------------------------------|
| (1) Axle nut | (4) Index mark |
| (2) Lock nut | (5) Rear edge of
adjusting slot |
| (3) Drive chain
adjusting nut | |

If the drive chain requires adjustment, the procedure is as follows:

1. Raise the rear wheel off the ground by placing a support under the engine with the transmission in neutral and the ignition switch off.
2. Loosen the axle nut (1).
3. Loosen the lock nuts (2) on both adjusting nuts (3).
4. Turn both adjusting nuts an equal number of turns until the correct drive chain slack is obtained. Turn the adjusting nuts clockwise to tighten the chain, or counterclockwise to provide more slack. Adjust the chain slack at a point midway between the drive sprocket and the rear wheel sprocket. Rotate the rear wheel and recheck slack at other sections of the chain.

Chain slack should be:

25–35 mm (1–1-3/8 in)

5. Check rear axle alignment by making sure the chain adjuster index marks (4) align with the rear edge (5) of the adjusting slots.

Both left and right marks should correspond. If the axle is misaligned, turn the left or right adjusting nut until the marks correspond on the rear edge of the adjusting slots and recheck chain slack.

6. Tighten the axle nut to:
95 N·m (9.5 kg-m, 69 ft-lb)
7. Tighten the adjusting nuts lightly, then tighten the lock nuts by holding the adjusting nuts with a spanner.
8. Rear brake pedal free play is affected when repositioning the rear wheel to adjust drive chain slack. Check rear brake pedal free play and adjust as necessary.

Wear inspection:

Check the chain wear label when adjusting the chain. If the red zone (6) on the label aligns with the arrow mark (7) on the chain adjuster plates after the chain has been adjusted to the proper slack, the chain is excessively worn and must be replaced. The proper slack is:

25–35 mm (1–1-3/8 in)

CAUTION:

- * **Excessive chain slack may damage the bottom part of the frame.**

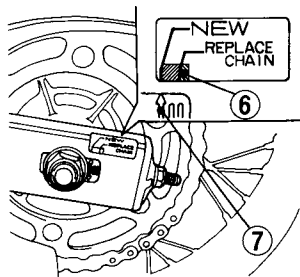

(6) Red zone

(7) Arrow mark

Lubrication and cleaning:

Lubricate every 1,000 km (600 miles) or sooner if chain appears dry.

The O-rings in this chain can be damaged by steam cleaning, high pressure washers, and certain solvents. Clean the chain with high flash point solvent, such as parafin. Wipe dry and lubricate only with SAE 80 or 90 gear oil. Commercial chain lubricants may contain solvents which could damage the rubber O-rings.

Replacement chain:

RK 520 TO or D.I.D 520 VC.7

When a new drive chain is installed, a new wear label must be attached according to the directions provided with the replacement chain. Since new chain lengths vary slightly, proper label placement is necessary to provide an accurate wear and replacement indication.

CAUTION:

- * **The drive chain on this motorcycle is equipped with small O-rings between the link plates. These O-rings retain grease inside the chain to improve its service life. However, special precautions must be taken when adjusting, lubricating, washing, and replacing the chain.**

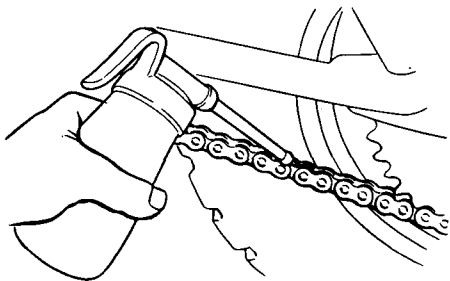

FRONT SUSPENSION

(Refer to the maintenance precautions on page 51, 52).

Check front fork action by locking the front brake and pumping the forks up and down several times. The suspension should function smoothly, with no oil leakage from the fork legs. Damaged, binding, or leaking front forks should be repaired before the motorcycle is operated. Check security of all front fork and handlebar mounting bolts.

WARNING

- * **Operating the motorcycle with loose, worn, or damaged steering or front suspension components may adversely affect vehicle handling and stability.**
- * **If any suspension components appear worn or damaged, consult your authorized Honda dealer for further inspection. The suspension components are directly related to safety and your authorized Honda dealer is qualified to determine whether or not replacement parts or repairs are needed.**

REAR SUSPENSION

(Refer to the maintenance precautions on page 51, 52).

Check the rear suspension periodically by careful visual examination. Note the following items.

1. Swingarm bearings should be checked by pushing hard against the side of the rear wheel while the motorcycle is on a support block. Free play indicates worn bearings.
2. Check all suspension component attaching points for security of their respective fasteners.
3. Check for oil leaks in the shock absorber units.

NOTE:

- * If any of the before mentioned components appear damaged or worn, consult your authorized Honda dealer for further inspection.

▲ WARNING

- * **The rear shock absorber assembly includes a damper unit that contains high pressure nitrogen gas. The instructions found in this owner's manual are limited to adjustment of the shock assembly only. Do not attempt to disassemble, disconnect or service the damper unit; an explosion causing serious injury may result.**
- * **Puncture or exposure to flame may also result in an explosion, causing serious injury.**
- * **Service or disposal should only be done by your authorized Honda dealer or a qualified mechanic, equipped with the proper tools, safety equipment and the official Honda Service Manual.**

SIDE STAND (F, ED, SP, DE)

(Refer to the maintenance precautions on page 51).

Check the rubber pad for deterioration and wear. Replace if wear extends to the wear mark (See (1) in the picture). Check the side stand assembly for freedom of movement. If parts must be replaced, please contact an authorized HONDA dealer.

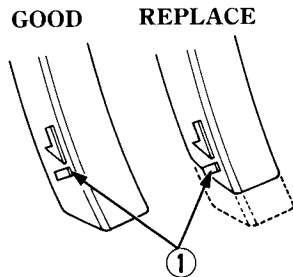

(1) Wear mark

SIDE STAND (G, IIG, ND, FI)

(Refer to the maintenance precautions on page 52).

Perform the following maintenance in accordance with the maintenance schedule.

Functional Check:

- Rest the motorcycle on the side stand as previously described.
- Raise the motorcycle. After leaving contact with the ground, the side stand should immediately retract automatically and fully.

- If the side stand moves sluggishly, lubricate the pivot area (1).
- Check the spring tension by pushing down the side stand. The side stand is doubly secured by two springs. If one of the springs should fail, be sure to replace it.
- If the side stand still moves sluggishly even after lubrication, if it does not retract fully, or if there is little or no spring tension, be sure to consult an authorized Honda dealer.

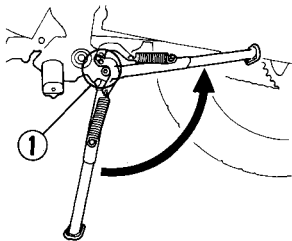

(1) Side stand pivot

WHEEL REMOVAL

(Refer to the maintenance precautions on page 51, 52).

Front Wheel Removal

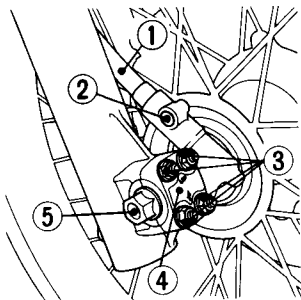

- (1) Speedometer cable (4) Axle holder
(2) Screw (5) Axle
(3) Axle holder nuts

NOTE:

* This motorcycle is equipped with a side stand only. Therefore, if front or rear wheel removal is required it will be necessary to raise the center of the motorcycle with a jack or other firm support. If none is available, see your authorized Honda dealer for this service.

1. Raise the front wheel off the ground by placing a support under the engine.
2. Remove the speedometer cable set screw (2) and disconnect the speedometer cable (1).
3. Remove the front axle nuts (3) and the front axle holder (4).
4. Unscrew the axle (5). Remove the wheel.

NOTE:

* Do not squeeze the brake lever when the wheel is off the motorcycle. The caliper piston will be forced out of the cylinder with subsequent loss of brake fluid. If this occurs, servicing of the brake system will be necessary. See your authorized Honda dealer.

Installation Notes:

- Reverse the removal procedure.
- Insert the axle through the wheel hub and left fork leg.
Make sure that the lug (6) on the speedometer gear box is behind the lug (7) on the right fork leg.
- Tighten the axle.

Axle torque:

65 N·m (6.5 kg-m, 47 ft-lb)

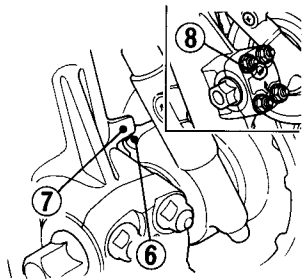

(6) Lug
(7) Lug

(8) UP mark

- Install the axle holder with the UP mark (8) upward and tighten the upper holder nuts to the specified torque first, then tighten the lower holder nuts to the same torque.
Axle holder nut torque:
12 N·m (1.2 kg-m, 9 ft-lb)
- After installing the wheel, apply the brake several times and check for free wheel rotation when released.

▲ WARNING

- * **If a torque wrench was not used for installation, see your authorized Honda dealer as soon as possible to verify proper assembly. Improper assembly may lead to loss of braking capacity.**

Rear Wheel Removal

1. Raise the rear wheel off the ground by placing a support under the motorcycle.
2. Remove the rear brake adjusting nut (1). Disconnect the brake rod (2) from the brake arm (3).
3. Loosen the drive chain adjusting nut lock nuts (4) and adjusting nuts (5).

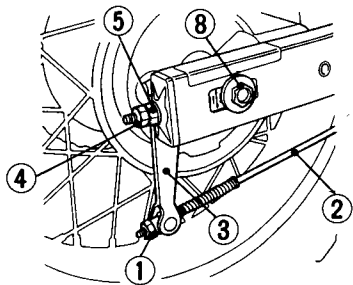

- (1) Adjusting nut (3) Brake arm
(2) Brake rod

4. Remove the rear axle nut (6).
5. Remove the drive chain (7) from the driven sprocket by pushing the rear wheel forward.
6. Remove the axle shaft (8) and rear wheel from the swingarm.

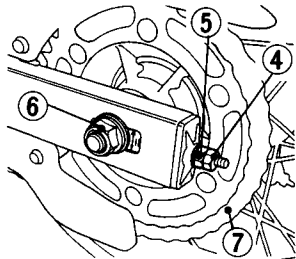

- (4) Lock nuts (7) Drive chain
(5) Adjusting nuts (8) Axle shaft
(6) Axle nut

Installation Notes:

- To install the rear wheel, reverse the removal procedure.
- Make sure the tang (9) on the swingarm is located in the slot (10) in the brake panel (11).
- Tighten the axle nut to the specified torque.
Axle nut torque:
95 N·m (9.5 kg-m, 69 ft-lb)
- Adjust the brake (page 15) and drive chain (pages 63–67)
- Apply the brake several times and check for free wheel rotation when released.

▲ WARNING

- * **If a torque wrench was not used for installation, see your authorized Honda dealer as soon as possible to verify proper assembly. Improper assembly may lead to loss of braking capacity.**

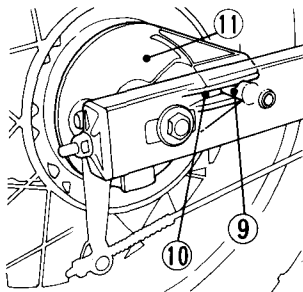

(9) Tang
(10) Slot

(11) Brake panel

BRAKE PAD WEAR

(Refer to the maintenance precautions on page 51, 52).

The front brake pad wear will depend upon the severity of usage, type of riding, and condition of the roads. The pads will wear faster on dirty and wet roads. Inspect the pads (1) visually from under the caliper (2) during all regular service

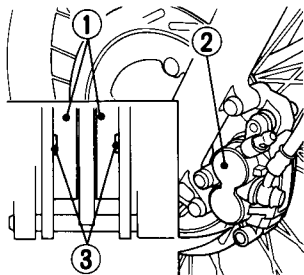

(1) Brake pads
(2) Caliper

(3) Wear limit

intervals to determine the pad wear. If either pad wears to the wear limit (3), both pads must be replaced as a set.

Other Checks:

Make sure there are no fluid leaks. Check for deterioration or cracks in the hose and fittings.

NOTE:

- * Use only genuine Honda replacement friction pads offered by authorized Honda dealers. When brake service is necessary consult your Honda dealer.

BRAKE SHOE WEAR

(Refer to the maintenance precautions on page 51, 52).

The rear brake is equipped with brake wear indicator.

When the brake is applied, an arrow (1) attached to the brake arm (2) moves toward a reference mark (3) on the brake panel (4).

If the arrow aligns with the reference mark on full application of the brake, the brake shoes must be replaced.

NOTE:

* When the brake service is necessary, see your authorized Honda dealer. Use only genuine Honda parts or its equivalent.

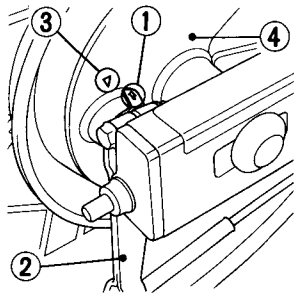

(REAR)

(1) Arrow

(2) Brake arm

(3) Reference mark

(4) Brake panel

BATTERY

(Refer to the maintenance precautions on page 51, 52).

It is not necessary to check the battery electrolyte level or add distilled water as the battery is a maintenance-free (sealed) type. If the battery loses electrolyte and/or seems weak (causing hard starting or other electrical troubles), contact your authorized Honda dealer.

CAUTION:

- * **Do not attempt to remove the sealing caps from the cells—you may damage the battery.**
- * **When this motorcycle is to be stored for an extended period of time, remove the battery and charge it fully. Then store it in a cool, dry place. If the battery is to be left in the motorcycle, disconnect the negative cable from the battery terminal.**

WARNING

- * **Even though the battery is sealed, it still vents explosive gases. Do not allow open flames or sparks near the battery.**
- * **The battery gives off explosive gases; keep sparks, flames, and cigarettes away. Provide adequate ventilation when charging or using the batteries in an enclosed space.**

⚠ WARNING

- * The battery contains sulfuric acid (electrolyte). Contact with skin or eyes may cause severe burns. Wear protective clothing and a face shield.
 - If electrolyte gets on your skin, flush with water.
 - If electrolyte gets in your eyes, flush with water for at least 15 minutes and call a physician immediately.
- * Electrolyte is poisonous.
 - If swallowed, drink large quantities of water or milk and follow with milk of magnesia or vegetable oil and call a physician.
- * **KEEP OUT OF REACH OF CHILDREN.**

FUSE REPLACEMENT

(Refer to the maintenance precautions on page 51, 52).

The main fuse (1), located behind the right side cover, is 20 A.

The fuse box (6) is near the seat lock. The specified fuses are 10 A and 15 A.

When frequent fuse failure occurs, it usually indicates a short circuit or an overload in the electrical system. See your authorized Honda dealer for repair.

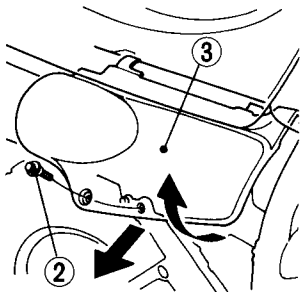

(2) Bolt

(3) Right side cover

CAUTION:

* **Turn the ignition switch OFF before checking or replacing fuses to prevent accidental short-circuiting.**

To replace the main fuse (1), remove the seat (page 34), bolt (2) and right side cover (3), disconnect the wire connector (4) of the stator magnetic switch and pull out the old fuse. Install a new fuse and reconnect the connector.

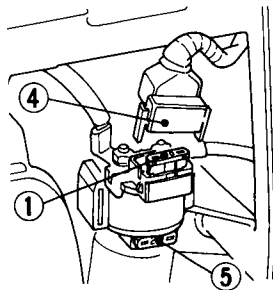

(1) Main Fuse

(4) Wire Connector

(5) Spare fuse

To replace fuses in the fuse box (6), remove the seat (page 34), bolt (8) and fuse box cover (7). Spare fuses (9) are located in the fuse box. Pull the old fuse out of the clips with the fuse remover (10). Push a new fuse into the clips and install the fuse box cover.

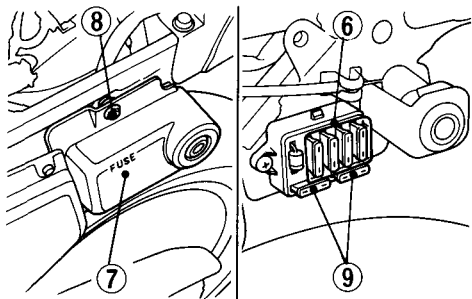

(6) Fuse box
(7) Cover

(8) Bolt
(9) Spare fuse

NOTE:

- * The fuse remover is furnished in the tool kit (see page 49).

⚠ WARNING

- * **Never use a fuse with a different rating from that specified. Serious damage to the electrical system or a fire may result, causing a dangerous loss of lights or engine power.**

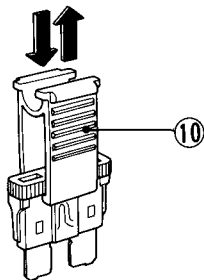

(10) Fuse remover

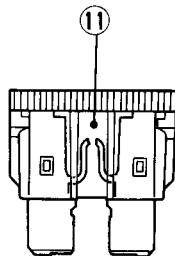

(11) Blown fuse

STOPLIGHT SWITCH ADJUSTMENT

(Refer to the maintenance precautions on page 51, 52).

Check the operation of the stoplight switch (1) at the right side behind the engine from time to time.

Adjustment is done by turning the adjusting nut (2). Turn the nut in the direction (A) if the switch operates too late and in direction (B) if the switch operates too soon.

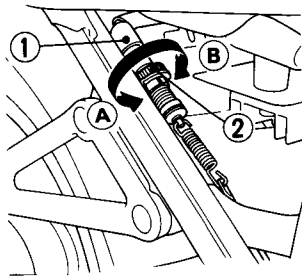

- (1) Stoplight switch
- (2) Adjusting nut

CLEANING

Clean your motorcycle regularly to protect the surface finishes and inspect for damage, wear, and oil, coolant or hydraulic fluid seepage.

CAUTION:

- * **Avoid spraying high pressure water (typical in coil-operated car washes) at the following areas:**

Wheel Hubs	Brake Master
Carburetor	Cylinder
Instruments	Muffler Outlet
Under Seat	Under Fuel Tank
Drive Chain	Handlebar Switches
Ignition Switch	

1. After cleaning, rinse the motorcycle thoroughly with plenty of clean water. Strong detergent residue can corrode alloy parts.
2. Dry the motorcycle, start the engine, and let it run for several minutes.

▲ WARNING

- * **Braking efficiency may be temporarily impaired immediately after washing the motorcycle. Anticipate longer stopping distance to avoid a possible accident.**
3. Test the brakes before riding the motorcycle. Several applications may be necessary to restore normal braking performance.
 4. Lubricate the drive chain immediately after washing the motorcycle.

STORAGE GUIDE

STORAGE

Extended storage, such as for winter, requires that you take certain steps to reduce the effects of deterioration from non-use of the motorcycle. In addition, necessary repairs should be made **BEFORE** storing the motorcycle; otherwise, these repairs may be forgotten by the time the motorcycle is removed from storage.

1. Change the engine oil and filter.
2. Lubricate the drive chain.
3. Make sure the cooling system is filled with a 50/50% antifreeze solution.
4. Drain the fuel tank and carburetors. Spray the inside of the tank with an aerosol rust-inhibiting oil.
Reinstall the fuel cap on the tank.

NOTE:

- * If storage will last more than one month, carburetor draining is very important, to assure proper performance after storage.

WARNING

- * **Petrol is flammable and is explosive under certain conditions. Do not smoke or allow flames or sparks near the equipment while draining fuel.**
5. Remove the spark plug and pour a tablespoon (15–20 cm³) of clean engine oil into each cylinder. Crank the engine several times to distribute the oil, then reinstall the spark plug.

NOTE:

- * When turning the engine over, the Engine Stop Switch should be OFF and spark plug placed in its cable cap and grounded to prevent damage to the ignition system.

6. Remove the battery. Store in an area protected from freezing temperatures and direct sunlight.
Slow charge the battery once a month.
7. Wash and dry the motorcycle. Wax all painted surfaces. Coat chrome with rust-inhibiting oil.
8. Inflate the tyres to their recommended pressures. Place the motorcycle on blocks to raise both tyres off the ground.
9. Cover the motorcycle (don't use plastic or other coated materials) and store in an unheated area, free of dampness with a minimum of daily temperature variation. Do not store the motorcycle in direct sunlight.

REMOVAL FROM STORAGE

1. Uncover and clean the motorcycle. Change the engine oil if more than 4 months have passed since the start of storage.
2. Charge the battery as required. Install the battery.
3. Drain any excess aerosol rust-inhibiting oil from the fuel tank. Fill the fuel tank with fresh petrol.
4. Perform all Pre-ride Inspection checks (page 35). Test ride the motorcycle at low speeds in a safe riding area away from traffic.

SPECIFICATIONS

DIMENSIONS

Overall length	F, ED, SP, DE: 2,085 mm (82.1 in)
Overall width	G, IIG, ND, FI: 2,095 mm (82.5 in)
Overall height	805 mm (31.7 in)
Wheelbase	1,120 mm (44.1 in)
	1,350 mm (53.1 in)

WEIGHT

Dry weight	118 kg (260 lbs)
------------	------------------

CAPACITIES

Engine oil	1.6 ℓ (1.7 US qt, 1.4 Imp qt) After disassembly
	1.35 ℓ (1.43 US qt, 1.19 Imp qt) After draining and oil filter change
Fuel tank	9.0 ℓ (2.4 US gal, 2.0 Imp gal)
Fuel reserve	2.0 ℓ (0.5 US gal, 0.4 Imp gal)
Cooling system capacity	1.2 ℓ (1.3 US qt, 1.1 Imp qt)
Passenger capacity load	Operator and one passenger
Marimum weight capacity	185 kg (407 lbs)

ENGINE

Bore and stroke	ED, SP, G, IIG, ND, FI, DE: 70 x 64.8 mm (2.8 x 2.55 in)
Compression ratio	F: 68.5 x 64.8 mm (2.7 x 2.55 in)
Displacement	11.0 : 1
Spark plug	ED, SP, G, IIG, ND, FI, DE: 249 cm ³ (15.2 cu-in)
Spark plug gap	F: 239 cm (14.8 cu-in)
Valve clearance	CR9EH9 (NGK) or U27FER9 (ND)
(Intake)	0.8—0.9 mm (0.031—0.035 in)
(Exhaust)	0.23 mm (0.009 in)
Idle speed	0.23 mm (0.009 in)
	1,300 ± 100 min ⁻¹ (rpm)

CHASSIS AND SUSPENSION

Caster	25°30'
Trail	89 mm (3.5 in)
Tyre size, front	90/100-19 55P
Tyre size, rear	120/90-16 63P

POWER TRANSMISSION

Primary reduction	2.7272
Gear ratio, 1st	2.8461
2nd	1.7777
3rd	1.3333
4th	1.0416
5th	0.8846
6th	0.7857
Final reduction	3.1538

ELECTRICAL

Battery	12V-6AH
Generator	204 W/5,000 min ⁻¹ (rpm)

LIGHTS

Headlight (HIGH/LOW)	12V-60/55W
Tail/stoplight	12V-5/21W
Turn signal light (Front/Rear)	12V-21W x 4
Instrument lights	12V-1.7W x 3
Neutral indicator light	12V-3W
Turn signal indicator light	12V-3W x 2
High beam indicator light	12V-1.7W

FUSE

10A x 3, 15A
20A (Main fuse)

NX250 (F, ED, ND, G, IIG, SP, FI)

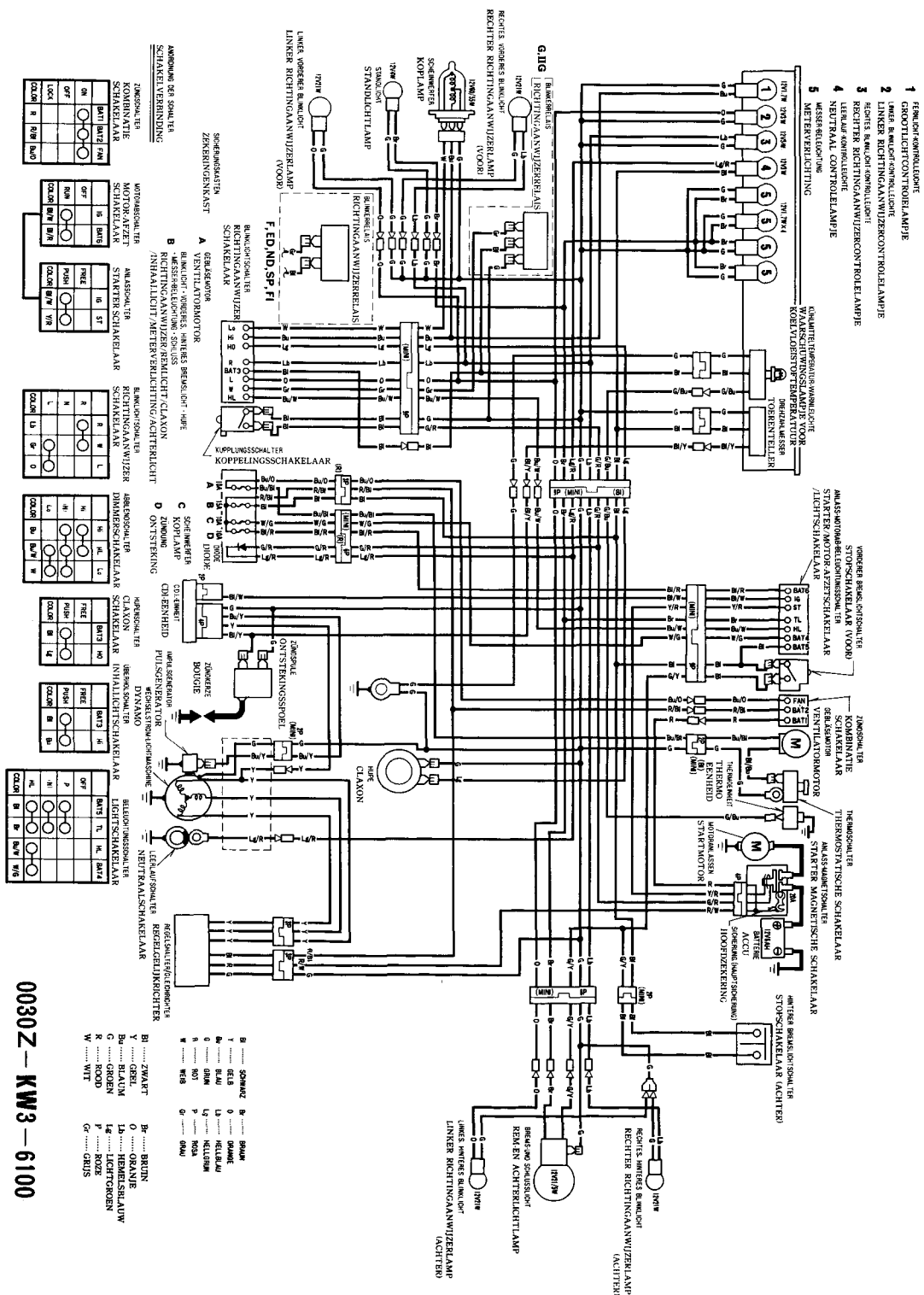

1. RIJBLICHT/RIJBLICHT
2. RIJBLICHT/RIJBLICHT
3. RIJBLICHT/RIJBLICHT
4. RIJBLICHT/RIJBLICHT
5. RIJBLICHT/RIJBLICHT

ANDERING VAN SOORTEN
SCHAKELVERBINDING

RIJBLICHT	RIJBLICHT	RIJBLICHT
ON	ON	ON
OFF	OFF	OFF
LOCK	R	R/W

RIJBLICHT	RIJBLICHT	RIJBLICHT
ON	ON	ON
OFF	OFF	OFF
LOCK	R	R/W

RIJBLICHT	RIJBLICHT	RIJBLICHT
ON	ON	ON
OFF	OFF	OFF
LOCK	R	R/W

RIJBLICHT	RIJBLICHT	RIJBLICHT
ON	ON	ON
OFF	OFF	OFF
LOCK	R	R/W

RIJBLICHT	RIJBLICHT	RIJBLICHT
ON	ON	ON
OFF	OFF	OFF
LOCK	R	R/W

RIJBLICHT	RIJBLICHT	RIJBLICHT
ON	ON	ON
OFF	OFF	OFF
LOCK	R	R/W

RIJBLICHT	RIJBLICHT	RIJBLICHT
ON	ON	ON
OFF	OFF	OFF
LOCK	R	R/W

RIJBLICHT	RIJBLICHT	RIJBLICHT
ON	ON	ON
OFF	OFF	OFF
LOCK	R	R/W

RIJBLICHT	RIJBLICHT	RIJBLICHT
ON	ON	ON
OFF	OFF	OFF
LOCK	R	R/W

RIJBLICHT	RIJBLICHT	RIJBLICHT
ON	ON	ON
OFF	OFF	OFF
LOCK	R	R/W

RIJBLICHT	RIJBLICHT	RIJBLICHT
ON	ON	ON
OFF	OFF	OFF
LOCK	R	R/W

RIJBLICHT	RIJBLICHT	RIJBLICHT
ON	ON	ON
OFF	OFF	OFF
LOCK	R	R/W

RIJBLICHT	RIJBLICHT	RIJBLICHT
ON	ON	ON
OFF	OFF	OFF
LOCK	R	R/W

- B SWART
- Y GEEL
- O ORANJE
- G GROEN
- R ROZE
- W WIT

0030Z - KW3 - 6100

