

# HONDA

OWNER'S MANUAL  
INSTRUKTIEBOEK  
MANUAL DEL PROPIETARIO

NX500  
NX650

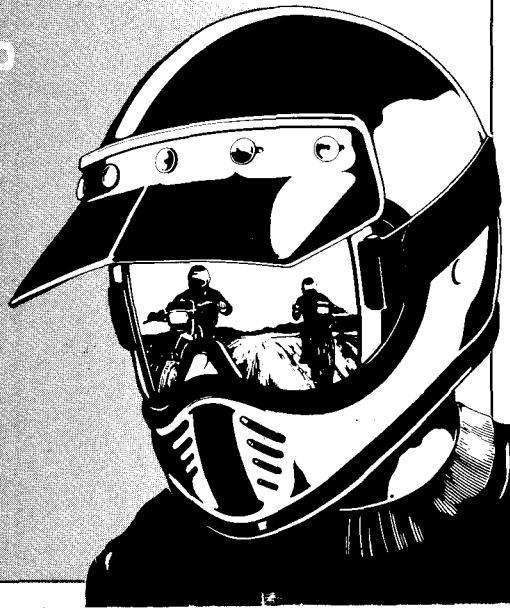



**HONDA**  
**NX500/NX650**

**OWNER'S MANUAL**

**INSTRUKTIEBOEK**

**MANUAL DEL PROPIETARIO**

## **IMPORTANT NOTICE**

- **OPERATOR AND PASSENGER**

This motorcycle is designed to carry the operator and one passenger. Never exceed the maximum weight capacity as shown on the tyre information label.

- **ON/OFF-ROAD USE**

This motorcycle is designed for “dual purpose” use.

- **READ THIS OWNER'S MANUAL CAREFULLY**

Pay special attention to statements preceded by the following words:

### **▲ WARNING**

**Indicates a strong possibility of severe personal injury or death if instructions are not followed.**

### **CAUTION:**

**Indicates a possibility of personal injury or equipment damage if instructions are not followed.**

**NOTE:** Gives helpful information.

This manual should be considered a permanent part of the motorcycle and should remain with the motorcycle when resold.

# **HONDA NX500/NX650 OWNER'S MANUAL**

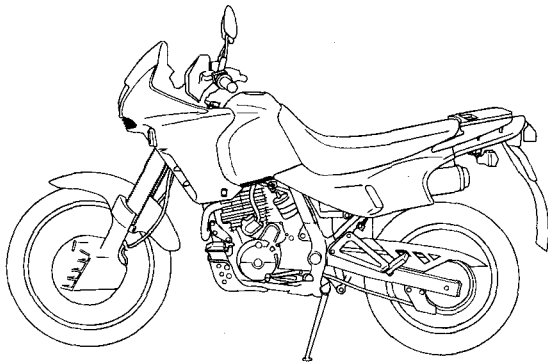

**All information in this publication is based on the latest production information available at the time of approval for printing. HONDA MOTOR CO.,LTD. reserves the right to make changes at any time without notice and without incurring any obligation.**

**No part of this publication may be reproduced without written permission.**

# WELCOME

The motorcycle presents you a challenge to master the machine, a challenge to adventure. You ride through the wind, linked to the road by a vehicle that responds to your commands as no other does. Unlike an automobile, there is no metal cage around you. Like an airplane, a pre-ride inspection and regular maintenance are essential to your safety. Your reward is freedom.

To meet the challenges safely, and to enjoy the adventure fully, you should become thoroughly familiar with this owner's manual **BEFORE YOU RIDE THE MOTORCYCLE**.

When service is required, remember that your Honda dealer knows your motorcycle best. If you have the required mechanical "know-how" and tools, your dealer can supply you with an official Honda Service Manual to help you perform many maintenance and repair tasks.

Pleasant riding, and thank you for choosing a Honda !

- Following codes in this manual indicate each country.

IG	Germany Finland
IIG	Germany II
E	UK
F	France
BR	Brazil

SW	Switzerland
ED	Europe Holland Portugal Belgium
U	Australia

AR	Austria
ND	Denmark Norway
SP	Spain

- \* IG...Full power type
- \* IIG...Limited power type

- The specifications may vary with each locale.

# **OPERATION**

## **Page**

1	<b>MOTORCYCLE SAFETY</b>
1	Safe Riding Rules
2	Protective Apparel
3	Modifications
4	Loading and Accessories
6	Off-road Safety
7	<b>PARTS LOCATION</b>
10	Instruments and Indicators
13	<b>MAJOR COMPONENTS</b> (Information you need to operate this motorcycle)
13	Brakes
17	Clutch
19	Fuel
23	Engine Oil
24	Tyres

## **Page**

26	<b>ESSENTIAL INDIVIDUAL COMPONENTS</b>
26	Ignition Switch
27	Right Handlebar Controls
28	Left Handlebar Controls
29	<b>FEATURES</b> (Not required for operation)
29	Steering Lock
30	Helmet Holder
31	Document Bag
32	<b>OPERATION</b>
32	Pre-ride Inspection
33	Starting the Engine
35	Running-in
36	Riding
37	Braking
38	Parking
38	Anti-theft Tips

## **MAINTENANCE**

<b>Page</b>	
39	<b>MAINTENANCE</b>
40	Maintenance Schedule
42	Tool Kit
43	Serial Numbers
44	Colour Label
45	Maintenance Precautions
46	Air Cleaner
47	Engine Oil
53	Crankcase Breather
54	Spark Plug
56	Throttle Operation
58	Idle Speed
59	Drive Chain
64	Front and Rear Suspension
66	Side Stand
67	Wheel Removal
71	Brake Pad Wear
73	Battery
74	Fuse Replacement
76	Stoplight Switch Adjustment

<b>Page</b>	
77	<b>CLEANING</b>
78	<b>STORAGE GUIDE</b>
78	Storage
79	Removal From Storage
80	<b>SPECIFICATIONS</b>
84	<b>NOISE CONTROL SYSTEM (AUSTRALIA ONLY)</b>

# MOTORCYCLE SAFETY

## ▲ WARNING

**\* Motorcycle riding requires special efforts on your part to ensure your safety. Know these requirements before you ride:**

### SAFE RIDING RULES

1. Always make a pre-ride inspection (page 32) before you start the engine. You may prevent an accident or equipment damage.
2. Many accidents involve inexperienced riders. Most countries require a special motorcycle riding test or license. Make sure you are qualified before you ride. NEVER lend your motorcycle to an inexperienced rider.
3. Many automobile/motorcycle accidents happen because the automobile driver does not “see” the motorcyclist. Make yourself conspicuous to help avoid the accident that wasn’t your fault:
  - Wear bright or reflective clothing.
  - Don’t ride in another motorist’s “blind spot.”
4. Obey all national and local laws and regulations.
  - Excessive speed is a factor in many accidents. Obey the speed limits, and NEVER travel faster than conditions warrant.
  - Signal before you make a turn or lane change. Your size and maneuverability can surprise other motorists.

5. Don't let other motorists surprise you. Use extra caution at intersections, parking lot entrances and exits, and driveways.
6. Keep both hands on the handlebars and both feet on the footpegs while riding. A passenger should hold on to the motorcycle or the operator with both hands and keep both feet on the passenger footpegs.

## **PROTECTIVE APPAREL**

1. Most motorcycle accident fatalities are due to head injuries: **ALWAYS** wear a helmet. You should also wear a face shield or goggles as well as boots, gloves and protective clothing. A passenger needs the same protection.
2. The exhaust system becomes hot during operation, and it remains hot for a while after stopping the engine. Be careful not to touch the exhaust system while it is hot. Wear clothing that fully covers your legs.
3. Do not wear loose clothing which could catch on the control levers, kickstarter, footpegs, drive chain or wheels.

## MODIFICATIONS

### **▲ WARNING**

- \* Modification of the motorcycle, or removal of original equipment, may render the vehicle unsafe or illegal. Obey all national and local equipment regulations.**

## LOADING AND ACCESSORIES

### **▲ WARNING**

**\*To prevent an accident, use extreme care when adding and riding with accessories and cargo. Addition of accessories and cargo can reduce a motorcycle's stability, performance and safe operating speed. Never ride an accessory-equipped motorcycle at speeds above 130 km/h (80 mph). And remember that this 130 km/h (80 mph) limit may be reduced by installation of non-Honda accessories, improper loading, worn tyres and overall motorcycle condition, poor road or weather conditions. These general guidelines may help you decide whether or how to equip your motorcycle and how to load it safely.**

### **Loading**

The combined weight of the rider, passenger, cargo and additional accessories must not exceed the maximum weight capacity:

**180 kg (396 lbs)**

Cargo weight alone should not exceed:

**9 kg (20 lbs)**

1. Keep cargo weight low and close to the center of the motorcycle. Load weight equally on both sides to minimize imbalance. As weight is located further from the motorcycle's center of gravity, handling is proportionally affected.
2. Adjust tyre pressure (page 24) to suit load weight and riding conditions.

3. Vehicle handling and stability can be adversely affected by loose cargo. Recheck cargo security and accessory mounts frequently.
4. Do not attach large or heavy items (such as a sleeping bag or tent) to the handlebars, fork, or fender. Unstable handling or slow steering response may result.

### **Accessories**

You are personally responsible for proper selection, installation, and use of non-Honda accessories. Always follow the guidelines under Loading, and these:

1. Carefully inspect the accessory to make sure it does not obscure lights, reduce ground clearance, or limit suspension travel, steering travel or control operation.
2. Luggage racks are for lightweight items. Bulky items may snag on a tree or other nearby object causing loss of control.
3. Do not add electrical equipment that will exceed the motorcycle's electrical system capacity. An electrical failure could cause a dangerous loss of lights or engine power at night, in traffic or far from help.

## **OFF-ROAD SAFETY**

Learn to ride in an uncongested off-road area free of obstacles before venturing onto unfamiliar terrain.

1. Always obey local off-road riding laws and regulations.
2. Obtain permission to ride on private property. Avoid posted areas and obey "NO Trespassing" signs.
3. Ride with a friend on another motorcycle so that you can assist each other in case of trouble.
4. Familiarity with your motorcycle is critically important should a problem occur far from help.
5. Never ride beyond your ability and experience or faster than conditions warrant.
6. If you are not familiar with the terrain, ride cautiously. Hidden rocks, holes, or ravines could spell disaster.

7. Spark arresters and mufflers are required in most off-road areas. Don't modify your exhaust system. Remember that excessive noise bothers everyone and creates a bad image for motorcycling.

# PARTS LOCATION

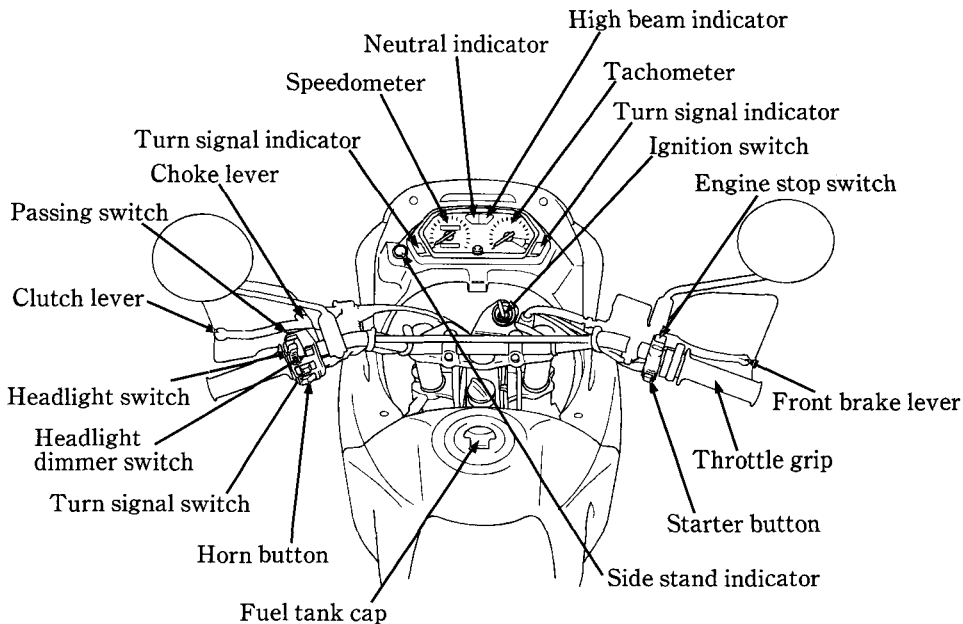

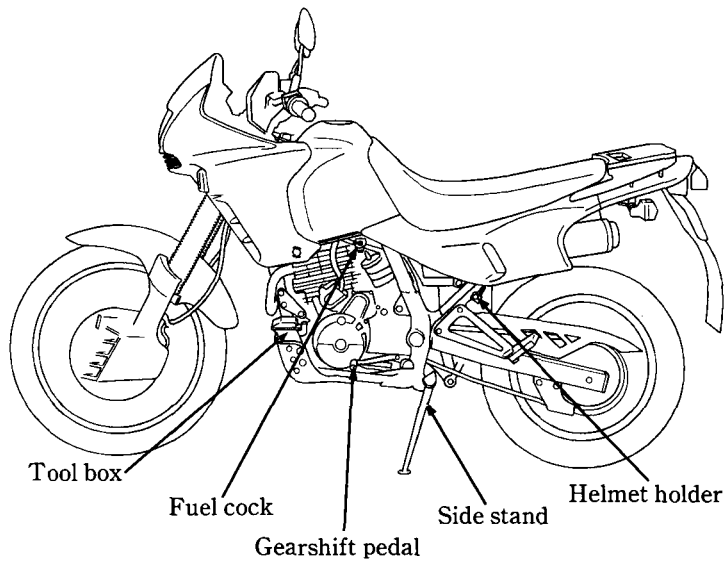

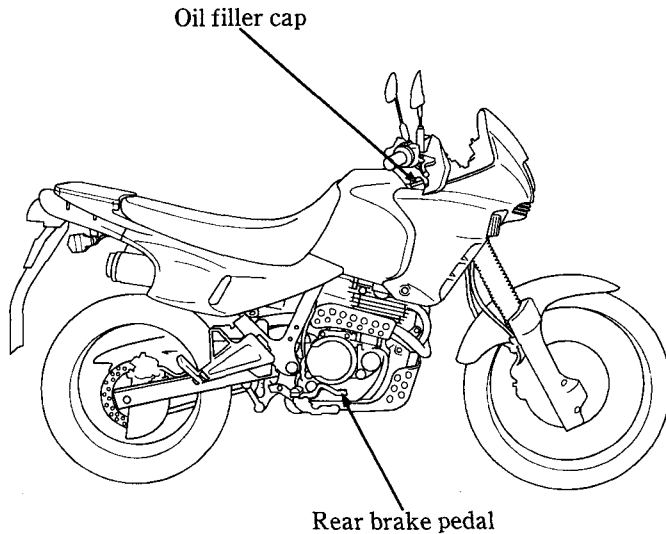

## INSTRUMENTS AND INDICATORS

The indicators are contained in the instrument panel. Their functions are described in the tables on the following pages.

- (1) Left turn signal indicator
- (2) Speedometer
- (3) Odometer
- (4) Neutral indicator
- (5) High beam indicator
- (6) Tachometer
- (7) Right turn signal indicator
- (8) Tachometer red zone
- (9) Tripmeter reset knob
- (10) Tripmeter
- (11) Side stand indicator

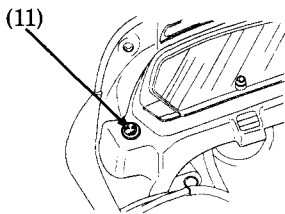
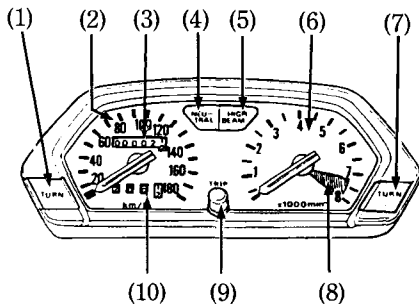

<b>(Ref. No.) Description</b>	<b>Function</b>
(1) Left turn signal indicator (amber)	Flashes when the left turn signal operates.
(2) Speedometer	Shows riding speed.
(3) Odometer	Shows accumulated mileage.
(4) Neutral indicator (green)	Lights when the transmission is in neutral.
(5) High beam indicator (blue)	Lights when the headlight is on high beam.
(6) Tachometer	Shows engine rpm.
(7) Right turn signal indicator (amber)	Flashes when the right turn signal operates.
(8) Tachometer red zone	<p>Never allow the tachometer needle to enter the red zone, even after the engine has been broken in.</p> <p><b>CAUTION:</b></p> <p><b>* Running the engine beyond recommended maximum engine speed (tachometer red zone) can damage the engine.</b></p>

<b>(Ref. No.) Description</b>	<b>Function</b>
(9) Tripmeter reset knob	Resets tripmeter to zero (0) by pushing the knob.
(10) Tripmeter	Shows mileage per trip.
(11) Side stand indicator (amber)	Lights when the side stand is put down. Before parking, check that the side stand is fully down; the light only indicates the side stand ignition cut-off system (page 33) is activated.

## MAJOR COMPONENTS (Information you need to operate this motorcycle)

### **▲ WARNING**

- \* If the Pre-ride Inspection (page 32) is not performed, severe personal injury or vehicle damage may result.

### **BRAKES**

Both the front and rear brakes are the hydraulic disc types.

As the brake pads wear, the brake fluid level drops.

There are no adjustments to perform, but fluid level and pad wear must be inspected periodically. The system must be inspected frequently to ensure there are no fluid leaks. If the control lever or pedal free travel becomes excessive and the brake pads are not worn beyond the recommended limit (page 71), there is probably air in the brake system and it must be bled. See your authorized Honda dealer for this service.

### Front Brake Fluid Level:

### **▲ WARNING**

- \* Brake fluid may cause irritation. Avoid contact with skin or eyes. In case of contact, flush thoroughly with water and call a doctor if your eyes were exposed.
- \* **KEEP OUT OF REACH OF CHILDREN.**

**CAUTION:**

- \* **Handle brake fluid with care because it can damage plastic and painted surfaces.**
- \* **When adding brake fluid, be sure the reservoir is horizontal before the cap is removed or brake fluid may spill out.**
- \* **Use only DOT 4 brake fluid from a sealed container.**
- \* **Never allow contaminants such as dirt or water to enter the brake fluid reservoir.**

Brake fluid must be added to the reservoir whenever the fluid level begins to reach the LOWER level mark (4). Remove the screws (1), reservoir cover (2), and diaphragm (3). Fill the reservoir with DOT 4 BRAKE FLUID from a sealed container up to the upper level mark (5). Reinstall the diaphragm and cover. Tighten the screws securely.

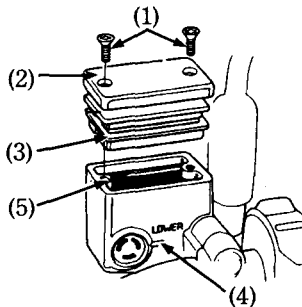

(FRONT)

- |                     |                      |
|---------------------|----------------------|
| (1) Screws          | (4) LOWER level mark |
| (2) Reservoir cover | (5) Upper level mark |
| (3) Diaphragm       |                      |

## Rear Brake Fluid Level:

### **▲ WARNING**

- \* Brake fluid may cause irritation. Avoid contact with skin or eyes. In case of contact, flush thoroughly with water and call a doctor if your eyes were exposed.
- \* **KEEP OUT OF REACH OF CHILDREN.**

### **CAUTION:**

- \* Handle brake fluid with care because it can damage plastic and painted surfaces.
- \* When adding brake fluid, be sure the reservoir is horizontal before the cap is removed or brake fluid may spill out.
- \* Use only DOT 4 brake fluid from a sealed container.
- \* Never allow contaminants such as dirt or water to enter the brake fluid reservoir.

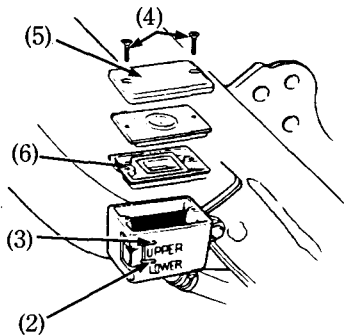

- (2) LOWER level mark
- (3) UPPER level mark
- (4) Screws
- (5) Reservoir cover
- (6) Diaphragm

Brake fluid must be added to the reservoir whenever the fluid level begins to reach the LOWER level mark (2). Remove the right side cover. Remove the screws (4), reservoir cover (5) and diaphragm (6). Fill the reservoir with DOT 4 BRAKE FLUID from a sealed container up to the UPPER level mark (3). Reinstall the diaphragm and cover. Tighten the screws securely.

Other Checks:

Make sure there are no fluid leaks. Check for deterioration or cracks in the hoses and fittings.

## CLUTCH

Clutch adjustment may be required if the motorcycle stalls when shifting into gear or tends to creep; or if the clutch slips, causing acceleration to lag behind engine speed. Minor adjustments can be made with the clutch cable adjuster (4) at the lever (1).

Normal clutch lever free play is:  
10–20 mm (0.4–0.8 in)

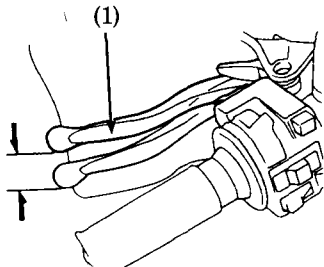

(1) Clutch lever

1. Pull back the rubber dust cover (2). Loosen the lock nut (3) and turn the adjuster (4). Tighten the lock nut (3) and check the adjustment.
2. If the adjuster is threaded out near its limit or if the correct free play cannot be obtained, loosen the lock nut (3) and turn in the cable adjuster (4) completely. Tighten the lock nut (3) and install the dust cover.

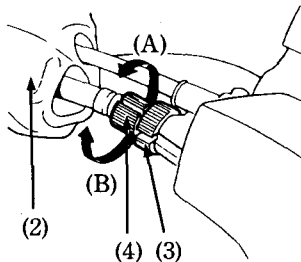

(2) Dust cover  
(3) Lock nut  
(4) Adjuster

(A) Increase free play  
(B) Decrease free play

- Loosen the lock nut (5) at the lower end of the cable. Turn the adjusting nut (6) to obtain the specified free play. Tighten the lock nut (5) and check the adjustment.
- Start the engine, pull in the clutch lever and shift into gear. Make sure the engine does not stall and the motorcycle does not creep. Gradually release the clutch lever and open the throttle. The motorcycle should begin to move smoothly and accelerate gradually.

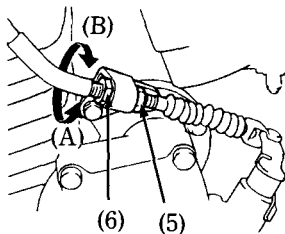

- |                   |                        |
|-------------------|------------------------|
| (5) Lock nut      | (A) Increase free play |
| (6) Adjusting nut | (B) Decrease free play |

#### NOTE:

- \* If proper adjustment cannot be obtained or the clutch does not work correctly, the cable or clutch friction discs may be worn. Refer to the official Honda shop manual or see your authorized Honda dealer.

#### Other Checks:

Check the clutch cable for kinks or signs of wear that could cause sticking or failure. Lubricate the clutch cable with a commercially available cable lubricant to prevent premature wear and corrosion.

## FUEL

### Fuel Cock

The three way fuel cock (1) is on the left underneath the fuel tank.

#### OFF

With the fuel cock in the OFF position, fuel cannot flow from the tank to the carburetor. Turn the cock OFF whenever the motorcycle is not in use.

#### ON

With the fuel cock in the ON position, fuel will flow from the main fuel supply to the carburetor.

#### RES

With the fuel cock in the RES position, fuel will flow from the reserve fuel supply to the carburetor. Use the reserve fuel only when the main supply is gone. Refill the tank as soon as possible after switching to RES.

The reserve fuel supply is:

2.5 l (0.66 US gal , 0.55 Imp gal)

### ▲ WARNING

- \* **To avoid running out of fuel that may result in a sudden stop, learn how to operate the fuel cock when riding the motorcycle.**
- \* **Be careful not to touch any hot engine parts while operating the fuel cock.**

#### NOTE:

- \* Remember to check that the fuel cock is in the ON position each time you refuel. If the cock is left in the RES position, you may run out of fuel with no reserve.

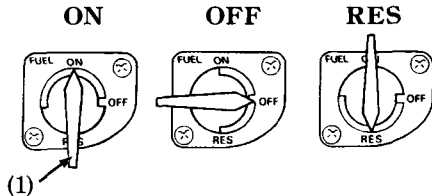

(1) Fuel cock

## Fuel Tank

The fuel tank capacity including the reserve supply is:

16 ℓ (4.2 US gal, 3.5 Imp gal)

To open the tank cap (1), insert the key (2) and turn it clockwise. The cap will pop up and can be lifted off.

After refueling, be sure to tighten the tank cap firmly by turning it counterclockwise until the arrow (3) on the cap faces forward.

Use unleaded or low-lead petrol with a research octane number of 91 or higher. We recommend that you use unleaded petrol because it produces fewer engine and spark plug deposits and extends the life of exhaust system components.

### FOR AUSTRALIA ONLY:

Use unleaded petrol with a research octane number of 91 or higher.

## CAUTION:

\* If “spark knock” or “pinking” occurs at a steady engine speed under normal load, change brands of petrol. If spark knock or pinking persists, consult your authorized Honda dealer. Failure to do so is considered misuse, and damage caused by misuse is not covered by Honda’s Limited Warranty.

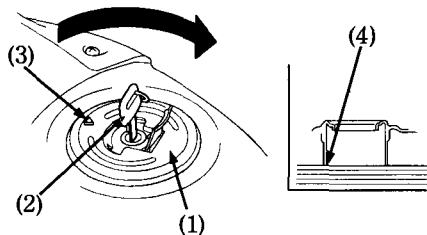

(1) Fuel cap  
(2) Ignition key

(3) Arrow  
(4) Filler neck

## **▲ WARNING**

- \* Petrol is extremely flammable and is explosive under certain conditions. Refuel in a well-ventilated area with the engine stopped. Do not smoke or allow flames or sparks in the area where petrol is stored or where the fuel tank is refueled.**
- \* Do not overfill the tank (there should be no fuel in the filler neck (4)). After refueling, make sure the fuel cap is closed securely.**
- \* Be careful not to spill fuel when refueling. Spilled fuel or fuel vapor may ignite. If any fuel is spilled, make sure the area is dry before starting the engine.**
- \* Avoid repeated or prolonged contact with skin or breathing of vapor. KEEP OUT OF REACH OF CHILDREN.**

## **Petrol Containing Alcohol**

If you decide to use a petrol containing alcohol (gasohol), be sure it's octane rating is at least as high as that recommended by Honda. There are two types of "gasohol": one containing ethanol, and the other containing methanol. Do not use petrol that contains more than 10% ethanol. Do not use petrol containing methanol (methyl or wood alcohol) that does not also contain cosolvents and corrosion inhibitors for methanol. Never use petrol containing more than 5% methanol, even if it has cosolvents and corrosion inhibitors.

**NOTE:**

- \* Fuel system damage or engine performance problems resulting from the use of fuels that contain alcohol is not covered under the warranty. Honda cannot endorse the use of fuels containing methanol since evidence of their suitability is as yet incomplete.
- \* Before buying fuel from an unfamiliar station, try to find out if the fuel contains alcohol. If it does, confirm the type and percentage of alcohol used. If you notice any undesirable operating symptoms while using a petrol that contains alcohol, or one that you think contains alcohol, switch to a petrol that you know does not contain alcohol.

## ENGINE OIL

### Engine Oil Level Check

Check the engine oil level each day before riding the motorcycle.

The level must be maintained between the UPPER (2) and LOWER (3) level marks on the dipstick (1).

1. Start the engine and let it idle for a few minutes.
2. Stop the engine and hold the motorcycle in an upright position on firm, level ground.
3. After a few minutes, remove the oil filler cap/dipstick (1), wipe it clean, and reinsert the dipstick without screwing it in. Remove the dipstick. The oil level should be between the UPPER (2) and LOWER (3) level marks on the dipstick.
4. If required, add the specified oil (see page 47) up to the UPPER level mark. Do not overfill.
5. Reinstall the oil filler cap/dipstick. Check for oil leaks.

### CAUTION:

\* Running the engine with insufficient oil pressure may cause serious engine damage.

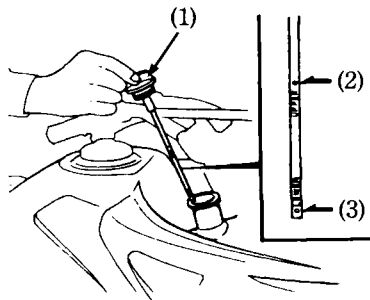

- (1) Filler cap/dipstick    (3) LOWER level mark  
(2) UPPER level mark

## **TYRES**

Proper air pressure will provide maximum stability, riding comfort and tyre life.

Check tyre pressure frequently and adjust if necessary.

### **NOTE:**

\* Tyre pressure should be checked before you ride while the tyres are "cold".

On/off-road tyres are standard on this model. Select the right replacement tyres in accordance with the following specifications.

Check the tyres for cuts, embedded nails, or other sharp objects. See your authorized Honda dealer for replacement of damaged tyres or punctured inner tubes.

		Front	Rear
Tyre size		90/90—21 54S	120/90—17 64S
Cold tyre pressures kPa (kg/cm <sup>2</sup> , psi)	Rider only	150 (1.5 , 22)	150 (1.5 , 22)
	Rider and passenger	150 (1.5 , 22)	200 (2.0 , 29)
Tyre brand	BRIDGESTONE DUNLOP	TW41 K560	TW42 K560

**▲ WARNING**

- \* Do not attempt to patch a damaged tyre or inner tube. Wheel balance and tyre reliability may be impaired.
- \* Improper tyre inflation will cause abnormal tread wear and create a safety hazard. Underinflation may result in the tyre slipping on, or coming off of the rim causing tyre deflation that may result in a loss of vehicle control.
- \* Operation with excessively worn tyres is hazardous and will adversely affect traction and handling.
- \* The use of tyres other than those listed on the tyre information label may adversely affect handling.

**▲ WARNING**

- \* Maintenance of spoke tension and wheel trueness are critical to safe motorcycle operation. During the first 1,000 km (600 miles) spokes will loosen more rapidly due to initial seating of parts. Excessively loose spokes may result in high speed instability and possible loss of control.

Replace tyres before tread depth at the center of the tyre reaches the following limit:

Minimum tread depth	
Front:	1.5 mm (0.06 in)
Rear:	2.0 mm (0.08 in)

# ESSENTIAL INDIVIDUAL COMPONENTS

## IGNITION SWITCH

The ignition switch (1) is located directly below the indicator panel.



(1) Ignition switch

Key Position	Function	Key Removal
LOCK (steering lock)	Steering is locked. Engine and lights cannot be operated.	Key can be removed.
OFF	Engine and lights cannot be operated.	Key can be removed.
ON	Engine and lights can be operated.	Key cannot be removed.
P (Parking) [AR]	For parking the motorcycle near traffic. The tail light and position light are on, but all other light are off. The engine cannot be started.	Key can be removed.

## **RIGHT HANDLEBAR CONTROLS**

### **Engine Stop Switch**

The engine stop switch (1) is next to the throttle grip. When the switch is in the RUN position, the engine will operate. When the switch is in the OFF position, the engine will not operate. This switch is intended primarily as a safety or emergency switch and should normally remain in the RUN position.

### **Starter Button**

The starter button (2) is below the engine stop switch (1).

When the starter button is pressed, the starter motor cranks the engine. See pages 33 — 34 for the starting procedure.

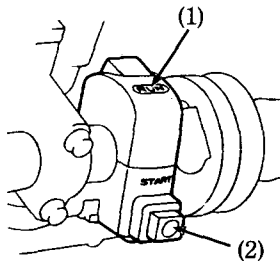

- (1) Engine stop switch
- (2) Starter button

## LEFT HANDLEBAR CONTROLS

### Headlight Switch (1) (Except U)

The headlight switch (1) has three positions: H, P and OFF, marked by a white dot.

H: Headlight, taillight, position light and meter lights on.

P: Position light, taillight and meter lights on.

OFF(dot): Headlight, taillight, position light and meter lights off.

### Headlight Dimmer Switch (2)

Push the dimmer switch to "HI" to select high beam or to "LO" to select low beam.

### Passing Light Control Switch (3)

When this switch is pressed, the headlight flashes on to signal approaching cars or when passing.

### Turn Signal Switch (4)

Move to L to signal a left turn, R to signal a right turn. Press to turn signal off.

### Horn Button (5)

Press the button to sound the horn.

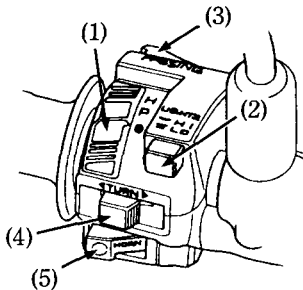

- (1) Headlight switch
- (2) Headlight dimmer switch
- (3) Passing light control switch
- (4) Turn signal switch
- (5) Horn button

## FEATURES

### (Not required for operation)

#### STEERING LOCK

(Except IG, IIG, ND, AR)

To lock the steering, turn the handlebars all the way to the left or right, turn the key (1) to LOCK while pushing in. Remove the key.

(IG, IIG, ND)

To lock the steering, turn the handlebars all the way to the right; turn the key (1) to LOCK while pushing in. Remove the key.

(AR)

To lock the steering, turn the handlebars all the way to the left or right, turn the key (1) to P or LOCK while pushing in. Remove the key.

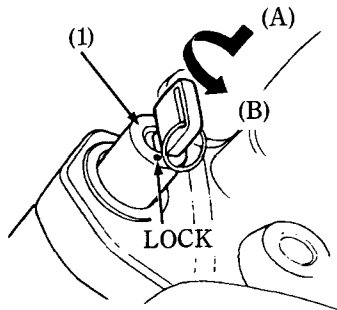

(1) Ignition key

(A) Push in  
(B) Turn to LOCK

#### **▲ WARNING**

**\* Do not turn the key to LOCK while riding the motorcycle; loss of vehicle control may result.**

## HELMET HOLDER

The helmet holder (1) is on the lower left side of the frame. Insert the ignition key (2) and turn it counterclockwise to unlock. Hang your helmet on the holder pin (3) and push it in to lock. Remove the key.

### ▲ WARNING

\* **The helmet holder is designed for helmet security while parked. Do not ride with a helmet attached to the holder; the helmet may interfere with safe operation and result in loss of control.**

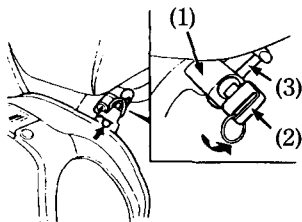

(1) Helmet holder  
(2) Ignition key

(3) Holder pin

## DOCUMENT BAG

The document bag (1) is attached to the left fairing.

This owner's manual and other documents should be stored in the document bag. When washing your motorcycle, be careful not to flood this area with water.

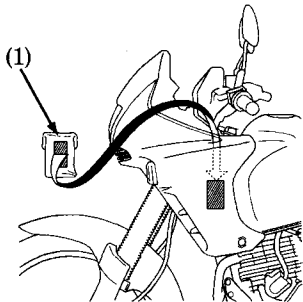

(1) Document bag

# OPERATION

## PRE-RIDE INSPECTION

### **▲ WARNING**

**\* If the Pre-ride Inspection is not performed, severe personal injury or vehicle damage may result.**

Inspect your motorcycle every day before you ride it. The items listed here will only take a few minutes to inspect, and in the long run they can save time, expense, and possibly your life.

1. Engine oil level—add engine oil if required (page 23 ). Check for leaks.
2. Fuel level—fill fuel tank when necessary (page 20 ). Check for leaks.
3. Front and rear brakes—check operation; make sure there is no brake fluid leakage (pages 13–16).
4. Tyres—check condition and pressure (pages 24–25).
5. Throttle—check for smooth opening and full closing in all steering positions.

6. Lights and horn—check that headlight, tail/brake light, turn signals, indicators and horn function properly.
7. Engine stop switch—check for proper function (page 27).
8. Side stand ignition cut-off system—check for proper function (page 66).
9. Drive chain—check condition and slack (page 59 ). Adjust and lubricate if necessary.

Correct any discrepancy before you ride. Contact your authorized Honda dealer for assistance if you cannot correct the problem.

## STARTING THE ENGINE

This motorcycle is equipped with a side stand ignition cut-off system. The engine cannot be started if the side stand is down, unless the transmission is in neutral. If the side stand is up, the engine can be started in neutral or in gear with the clutch lever pulled in. After starting with the side stand down, the engine will shut off if the transmission is put in gear before raising the side stand.

### **▲ WARNING**

**\* Never run the engine in an enclosed area. The exhaust contains poisonous carbon monoxide gas that can cause loss of consciousness and lead to death.**

### NOTE:

\* Do not use the electric starter for more than 5 seconds at a time. Release the starter button for approximately 10 seconds before pressing it again.

## Preparation

Before starting, insert the key, turn the ignition switch ON and confirm the following:

- The transmission is in NEUTRAL (neutral indicator light ON).
- The engine stop switch is at RUN.
- The fuel cock is ON.

## Starting Procedure

1. Pull the choke lever (1) back all the way to Fully ON (A), if the engine is cold.
2. Press the starter button or operate the kickstarter to start the engine. Starting from the top of the stroke, kick through to the bottom with a rapid, continuous motion. Do not operate the throttle.
3. Warm up the engine until it runs smoothly, with the choke lever Fully OFF.

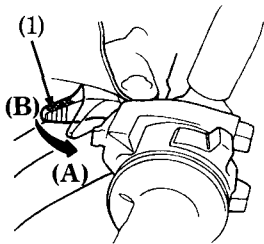

(1) Choke lever

## Flooded Engine

If the engine fails to start after repeated attempts, it may be flooded with excess fuel. To clear a flooded engine, turn the engine stop switch OFF and push the choke lever forward to Fully OFF (B). Open the throttle fully and crank the engine several times. Wait 10 seconds, then turn the engine stop switch to RUN and follow the Starting Procedure.

## **RUNNING-IN**

During the first 1,000km (600 miles), do not operate the motorcycle at more than 80% of the maximum speed in any gear. Avoid full throttle operation, and do not operate for a long time at one speed.

During initial running-in newly machined surfaces will be in contact with each other and these surfaces will wear in quickly. Running-in maintenance at 1,000km (600 miles) is designed to compensate for this initial minor wear. Timely performance of the running-in maintenance will ensure optimum service life and performance from the engine.

## RIDING

### ▲ WARNING

- \* Review **Motorcycle Safety (pages 1 – 6)** before you ride.
- \* **Make sure the side stand is fully retracted before riding the motorcycle.**

### NOTE:

- \* Make sure you understand the function of the side stand mechanism. (See **MAINTENANCE SCHEDULE** on page 41 and explanation for **SIDE STAND** on page 66 )
1. After the engine has been warmed up, the motorcycle is ready for riding.
  2. While the engine is idling, pull in the clutch lever and depress the gearshift pedal to shift into 1st (low) gear.
  3. Slowly release the clutch lever and at the same time gradually increase engine speed by opening the throttle. Coordination of the throttle and clutch lever will assure a smooth positive start.

4. When the motorcycle attains a moderate speed, close the throttle, pull in the clutch lever and shift to 2nd gear by raising the gearshift pedal.
5. This sequence is repeated to progressively shift to 3rd, 4th and 5th (top) gears.
6. Coordinate the throttle and brakes for smooth deceleration.

Both front and rear brakes should be used at the same time and should not be applied strongly enough to lock the wheel, or braking effectiveness will be reduced and control of the motorcycle be difficult.

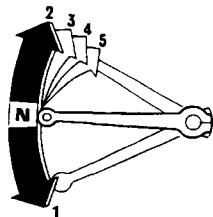

## **BRAKING**

1. For normal braking, gradually apply both the front and rear brakes while downshifting to suit your road speed.
2. For maximum deceleration, close the throttle and apply the front and rear brakes firmly. Pull in the clutch lever before coming to a complete stop to prevent stalling the engine.

### **▲WARNING**

- \* **Independent use of only the front or rear brake reduces stopping performance. Extreme braking may cause either wheel to lock, reducing control of the motorcycle.**
- \* **When possible, reduce speed or brake before entering a turn; closing the throttle or braking in mid-turn may cause wheel slip. Wheel slip will reduce control of the motorcycle.**

### **▲WARNING**

- \* **When riding in wet or rainy conditions, or on loose surfaces, the ability to maneuver and stop will be reduced. All of your actions should be smooth under these conditions. Rapid acceleration, braking or turning may cause loss of control. For your safety, exercise extreme caution when braking, accelerating or turning.**
- \* **When descending a long, steep grade, use engine compression braking by downshifting, with intermittent use of both brakes. Continuous brake application can overheat the brakes and reduce their effectiveness.**
- \* **Riding with your foot resting on the brake pedal or your hands on the brake lever may actuate the brakelight, giving a false indication to other drivers. It may also overheat the brake, reducing effectiveness.**

## PARKING

1. After stopping the motorcycle, shift the transmission into neutral, turn the fuel cock OFF, turn the handlebar fully to the left, turn the ignition switch OFF and remove the key.
2. Use the side stand to support the motorcycle while parked.

### CAUTION:

- \* **Park the motorcycle on firm, level ground to prevent it from falling over.**
  - \* **If you must park on a slight incline, aim the front of the motorcycle uphill to reduce the possibility of rolling off the side stand or overturning.**
3. Lock the steering to help prevent theft (page 29).

## ANTI-THEFT TIPS

1. Always lock the steering and never leave the key in the ignition switch. This sounds simple but people do forget.
2. Be sure the registration information for your motorcycle is accurate and current.
3. Park your motorcycle in a locked garage whenever possible.
4. Use an additional anti-theft device of good quality.
5. Put your name, address, and phone number in this Owner's Manual and keep it on your motorcycles at all times. Many times stolen motorcycles are identified by information in the Owner's Manuals that are still with them.

NAME: \_\_\_\_\_

ADDRESS: \_\_\_\_\_

PHONE NO. : \_\_\_\_\_

## **MAINTENANCE**

- When service is required, remember that your authorized Honda dealer knows your motorcycle best and is fully equipped to maintain and repair it. The scheduled maintenance may also be performed by a qualified service facility that normally does this kind of work; or you may perform most of the work yourself if you are mechanically qualified and have the proper tools and service data.
- These instructions are based on the assumption that the motorcycle will be used exclusively for its designed purpose. Sustained high speed operation, or operation in unusually wet or dusty conditions, will require more frequent service than specified in the MAINTENANCE SCHEDULE. Consult your authorized Honda dealer for recommendations applicable to your individual needs and use.

## MAINTENANCE SCHEDULE

The following items require some mechanical knowledge. Certain items (particularly those marked \* and \* \*) may require more technical information and tools. Consult your authorized Honda Dealer.

Perform the Pre-ride Inspection (page 32 ) at each scheduled maintenance period.

I: INSPECT AND CLEAN, ADJUST, LUBRICATE OR REPLACE IF NECESSARY

C: CLEAN R: REPLACE A: ADJUST L: LUBRICATE

ITEMS	FREQUENCY	WHICHEVER COMES FIRST ↓ NOTE	ODOMETER READING [NOTE (1)]								Refer to pages
			→	1	6	12	18	24	30	36	
			x 1.000 km x 1.000 mi	0.6	4	8	12	16	20	24	
		MONTHS	6	12	18	24	30	36			
* FUEL LINE					I		I		I	—	
* FUEL STRAINER SCREEN				C	C	C	C	C	C	—	
* THROTTLE OPERATION					I		I		I	56-57	
* CARBURETOR CHOKE					I		I		I	—	
AIR CLEANER	NOTE (2)						R		R	46	
CRANKCASE BREATHER	NOTE (3)			C	C	C	C	C	C	—	
SPARK PLUG				I	R	I	R	I	R	54-55	
* VALVE CLEARANCE			I	I	I	I	I	I	I	—	
ENGINE OIL			R	EVERY 3,000 km (2,000 mi) R						R	47-51
ENGINE OIL FILTER			R		R		R		R	52-53	
* ENGINE OIL STRAINER SCREEN IN DOWN TUBE					C		C		C	—	
* CARBURETOR IDLE SPEED			I	I	I	I	I	I	I	58	
* SECONDARY AIR SUPPLY SYSTEM	NOTE (4)				I		I		I	—	

ITEMS	FREQUENCY	WHICHEVER → COMES FIRST ↓	ODOMETER READING [NOTE (1)]									Refer to pages
			x 1,000 km	1	6	12	18	24	30	36		
			x 1,000 mi	0.6	4	8	12	16	20	24		
NOTE	MONTH		6	12	18	24	30	36				
DRIVE CHAIN	NOTE (5)		EVERY 1,000 km (600 mi) I, L									59-63
DRIVE CHAIN SLIDER				I	I	I	I	I	I	I	60	
BRAKE FLUID	NOTE (6)			I	I	R	I	I	R		13-16	
BRAKE PAD WEAR				I	I	I	I	I	I		71-72	
BRAKE SYSTEM			I		I		I		I		13-16,71	
* BRAKE LIGHT SWITCH					I		I		I		76	
* HEADLIGHT AIM					I		I		I		-	
CLUTCH SYSTEM			I	I	I	I	I	I	I	I	-	
SIDE STAND					I		I		I		66	
* SUSPENSION					I		I		I		64-65	
* NUTS, BOLTS, FASTENERS	NOTE (5)		I		I		I		I		-	
** WHEELS/TYRES	NOTE (5)		I	I	I	I	I	I	I	I	-	
** STEERING HEAD BEARINGS			I		I		I		I		-	

\* SHOULD BE SERVICED BY YOUR AUTHORIZED HONDA DEALER, UNLESS THE OWNER HAS PROPER TOOLS AND SERVICE DATA AND IS MECHANICALLY QUALIFIED. REFER TO THE OFFICIAL HONDA SHOP MANUAL.

\*\* IN THE INTEREST OF SAFETY, WE RECOMMEND THESE ITEMS BE SERVICED ONLY BY YOUR AUTHORIZED HONDA DEALER.

NOTES:

- (1) At higher odometer readings, repeat at the frequency interval established here.
- (2) Service more frequently when riding in unusually wet or dusty areas.
- (3) Service more frequently when riding in rain or at full throttle.
- (4) Switzerland, Germany and Austria type only.
- (5) Service more frequently when riding OFF-ROAD.
- (6) Replace every 2 years, or at indicated odometer interval, whichever comes first. Replacement requires mechanical skill.

## TOOL KIT

The tool box (1) is attached to the frame down tube.

To open the tool box, insert the ignition key (2) turn it counterclockwise.

- 10 x 12 mm box end wrench
- 17 mm box end wrench
- 24 mm box end wrench
- Handlebar
- Spark plug wrench
- 8 mm open end wrench
- 10 x 12 mm open end wrench
- 14 x 17 mm open end wrench
- Pliers
- No. 2 Phillips screwdriver
- No. 3 Phillips screwdriver
- No. 2 screwdriver
- 6 mm hex wrench
- Tool bag

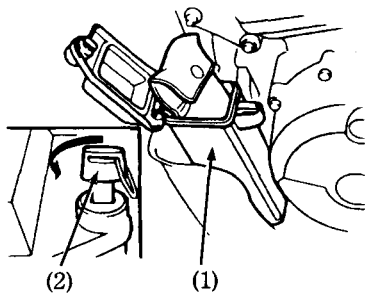

(1) Tool box

(2) Ignition key

## SERIAL NUMBERS

The frame and engine serial numbers are required when registering your motorcycle. They may also be required by your dealer when ordering replacement parts.

Record the numbers here for your reference.

FRAME NO. \_\_\_\_\_

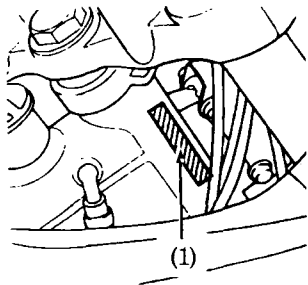

(1) Frame number

The frame number (1) is stamped on the right side of the steering.

The engine number (2) is stamped on the left side of the crankcase.

ENGINE NO. \_\_\_\_\_

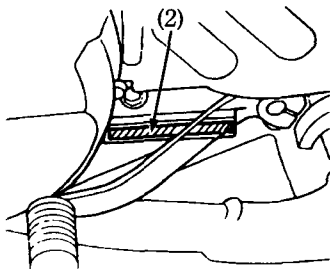

(2) Engine number

## COLOUR LABEL

The colour label (1) is attached to the frame.

It is helpful when ordering replacement parts. Record the colour and code here for your reference.

COLOUR \_\_\_\_\_

CODE \_\_\_\_\_

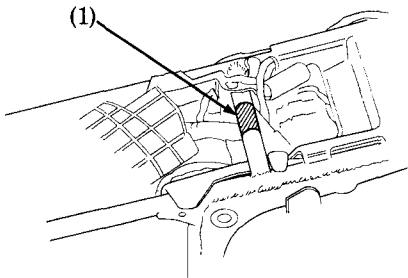

(1) Colour label

## MAINTENANCE PRECAUTIONS

### **▲ WARNING**

- \* If your motorcycle is overturned or involved in a collision, inspect control levers, cables, brake hoses, calipers, accessories, and other vital parts for damage. Do not ride the motorcycle if damage impairs safe operation. Have your authorized Honda dealer inspect the major components, including frame, suspension and steering parts, for misalignment and damage that you may not be able to detect.**
- \* Stop the engine and support the motorcycle securely on a firm, level surface before performing any maintenance.**
- \* Use new, genuine Honda parts or their equivalent for maintenance and repair. Parts which are not of equivalent quality may impair the safety of your motorcycle.**

## AIR CLEANER

(Refer to the maintenance precautions on page 45 ).

The air cleaner should be serviced at regular intervals (page 40 ). Service more frequently when riding in unusually wet or dusty areas.

1. Remove the left side cover (1).
2. Remove the air cleaner cover screws (2) and the cover (3).

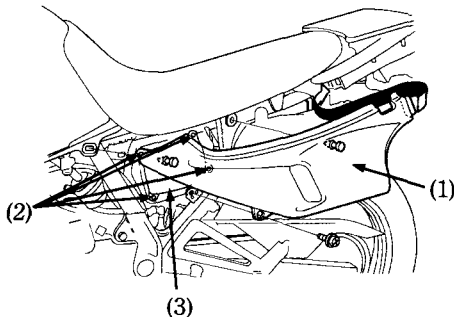

- (1) Left side cover      (3) Air cleaner case cover  
(2) Screws

3. Release the hooks (4) and remove the air cleaner element (5).
4. Discard the air cleaner element and reinstall a new one.

Use the Honda genuine air filter or an equivalent filter specified for your model. Using the wrong Honda filter or a non-Honda filter which is not of equivalent quality may cause premature engine wear or performance problems.

5. Install the removed parts in the reverse order of disassembly.

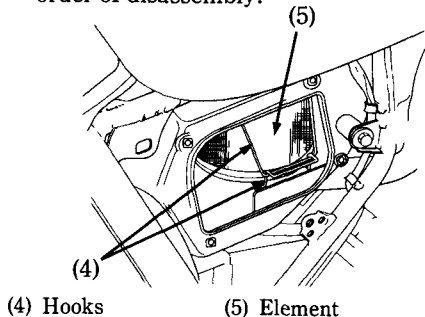

- (4) Hooks      (5) Element

## ENGINE OIL

(Refer to the maintenance precautions on page 45).

### Engine Oil

Good engine oil has many desirable qualities. Use only high detergent, quality motor oil certified on the container to meet or exceed requirements for service SE, SF or SG.

### Viscosity:

Viscosity grade of engine oil should be based on average atmospheric temperature in your riding area. The following provides a guide to the selection of the proper grade or viscosity of oil to be used at various atmospheric temperatures.

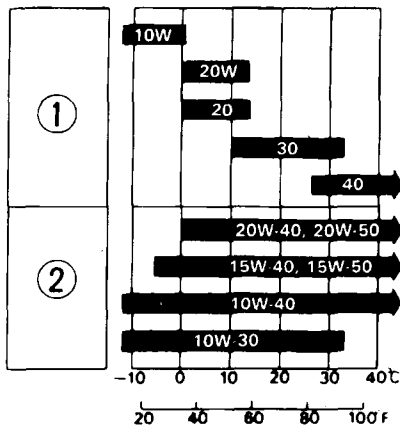

(1) Single grade

(2) Multigrade

## Engine Oil

Engine oil quality is the chief factor affecting engine service life. Change the engine oil as specified in the maintenance schedule (page 40).

### NOTE:

\* Change the engine oil with the engine at normal operating temperature and the motorcycle on its side stand to assure complete and rapid draining.

1. Start the engine and let it idle for a few minutes.
2. Stop the engine and remove the oil filler cap/dipstick (1).

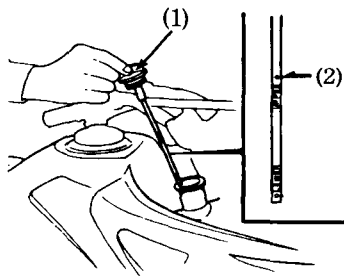

- (1) Oil filler cap/dipstick  
(2) UPPER level mark

3. Remove the skid plate and place an oil drain pan under the crankcase. Remove the drain bolt (3) on the frame down tube and drain plug (4) on the left crankcase.

**▲ WARNING**

**\* A warmed-up engine and the oil in it are hot; be careful not to burn yourself.**

4. After the oil has completely drain, make sure the sealing on the drain plug and bolt are in good condition.

5. Install the drain bolts to the specified torque.

Crankcase drain bolt torque:

25 N·m (2.5 kg-m , 18 lb-ft)

Frame drain bolt torque:

35 N·m (3.5 kg-m , 25 lb-ft)

**CAUTION:**

**\* To fill the oil tank up to the upper level, oil should be added in two steps.**

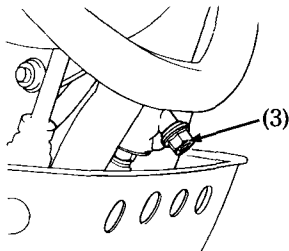

(3) Drain bolt

6. Fill the oil tank with the specified oil and install the oil filler cap/dipstick. For an oil change, the total quantity is about:

1.9 ℓ (2.0 US qt , 1.7 Imp qt)

7. With the motorcycle upright on firm level ground, start the engine and let it idle for a few minutes.

8. Stop the engine and, if necessary, add the specified oil (See page 47) up to the upper level mark.

9. Reinstall skid plate and the filler cap/dipstick. Check for oil leaks.

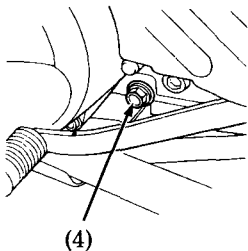

(4) Drain plug

#### NOTE:

- \* The engine contains a crankcase oil level check bolt (5). The oil level is correct if it is flush with the lower edge of the check bolt hole.
- \* Be sure to start the engine and allow it to idle for a few minutes, then stop the engine and make this check.

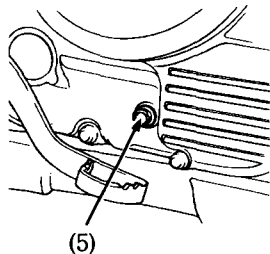

(5) Oil level ckeck bolt

**NOTE:**

- \* Do not check the oil level immediately after the engine has been operated at high speeds. Make sure that motorcycle is standing upright on firm level ground while idling.
- \* Please dispose of used engine oil in a manner that is compatible with the environment. We suggest you take it in a sealed container to your local recycling center or service station for reclamation. Do not throw it in the rubbish or pour it on the ground.

**CAUTION:**

- \* **Used engine oil may cause skin cancer if repeatedly left in contact with the skin for prolonged periods. Although this is unlikely unless you handle used oil on a daily basis, it is still advisable to thoroughly wash your hands with soap and water as soon as possible after handling used oil.**
- \* **Running the engine with insufficient oil can cause serious engine damage.**

## Engine Oil Filter

### NOTE:

- \* Change the filter after draining the engine oil.
1. Remove the oil filter bolts (1) and cover (2).

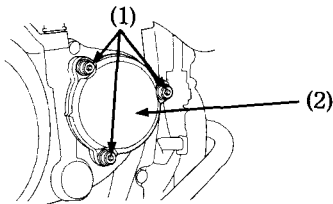

(1) Oil filter bolts      (2) Oil filter cover

2. Remove the oil filter element (3) from the cover.
3. Check that the oil filter cover O-ring (4) is in good condition and then install the new oil filter.

Use only the Honda genuine oil filter or a filter of equivalent quality specified for your model. Using the wrong Honda filter or a non-Honda filter which is not of equivalent quality may cause engine damage.

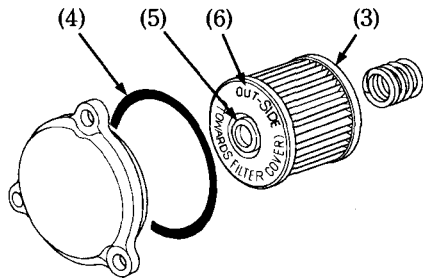

(3) Element      (5) Rubber seal  
(4) O-ring      (6) OUT-SIDE mark

4. Install the filter with the rubber seal facing out, away from the engine. You will see “OUT-SIDE (TOWARDS FILTER COVER)” mark on the filter body, near the seal.

**CAUTION:**

\* **Improper installation of the oil filter can cause serious engine damage.**

5. Reinstall the oil filter cover (2), making sure the bolts are tightened securely.

Oil Filter Bolt Torque:

12 N·m (1.2 kg·m, 9 lb·ft)

6. Perform steps 6 – 9 of Engine Oil Change.

Engine oil after draining and oil filter change:

1.95 ℓ (2.06 US qt, 1.72 Imp qt)

## CRANKCASE BREATHER

(Refer to the maintenance precautions on page 45).

1. Remove the drain plug (1) from the tube and drain deposits into a suitable container.
2. Reinstall the drain plug.

**NOTE:**

\* Service more frequently when riding in rain, at full throttle, or after the motorcycle is washed or overturned. Service if the deposit level can be seen in the transparent section of the drain tube.

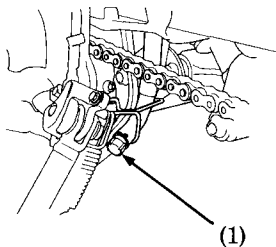

(1) Drain plug

## SPARK PLUG

(Refer to the maintenance precautions on page 45).

Recommended plugs:

Standard:

DPR8EA-9 (NGK) or  
X24EPR-U9 (NIPPONDENSO)

For cold climate: (Below 5°C, 41°F)

DPR7EA-9 (NGK) or  
X22EPR-U9 (NIPPONDENSO)

For extended high speed riding:

DPR9EA-9 (NGK) or  
X27EPR-U9 (NIPPONDENSO)

For most riding conditions this spark plug heat range number is satisfactory. However, if the motorcycle is going to be operated for extended periods at high speeds or near maximum power in hot climates, the spark plug should be changed to a colder heat range (a higher number).

1. Clean any dirt from around the spark plug base.
2. Disconnect the spark plug cap and remove the spark plug with the multipurpose wrench provided in the tool bag.

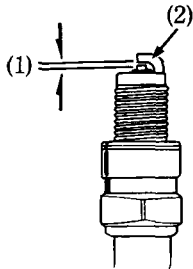

(1) Spark plug gap

(2) Side electrode

3. Visually inspect the spark plug electrodes for wear. The center electrode should have square edges and the side electrode should not be eroded.

Discard the spark plug if there is apparent wear or if the insulator is cracked or chipped.

4. Check the spark plug gap (1) using a wire-type feeler gauge. If adjustment is necessary, bend the side electrode (2) carefully.

The gap should be:

0.80—0.90 mm (0.031—0.035 in)

Make sure the plug washer is in good condition.

5. With the plug washer attached, thread the new spark plug in by hand to prevent cross-threading.

6. Tighten a new spark plug  $1/2$  turn with a spark plug wrench to compress the washer. If you are reusing a plug, it should only take  $1/8$ — $1/4$  turn after the plug seats.

**CAUTION:**

- \* The spark plug must be securely tightened. An improperly tightened plug can become very hot and possibly damage the engine.
- \* Never use a spark plug with an improper heat range. Severe engine damage could result.

## THROTTLE OPERATION

(Refer to the maintenance precautions on page 45).

### Cable Inspection:

Check for smooth rotation of the throttle grip from the fully open to the fully closed in all steering positions. Inspect the condition of the throttle cables from the throttle grip down to the carburetor. If the cables are kinked, chafed or improperly routed, they should be replaced or rerouted.

Check the cables for tension or stress at all steering position. Lubricate the throttle cables with a commercially available cable lubricant to prevent premature wear and corrosion.

### **▲ WARNING**

**\* For safe operation and positive engine response, the throttle cable must be properly adjusted.**

### Free Play Adjustment:

Measure the throttle grip free play at the throttle grip flange.

The standard free play should be approx:

2—6 mm (0.08—0.24 in)

Major free play adjustments, such as after replacing the throttle cables or removing the carburetor, are made with the lower adjuster (2). Minor free play adjustments are made with the upper adjuster (4). To adjust free play, loosen the lock nut (1) or (3), and turn the adjuster (2) or (4). Tighten the lock nut after adjustment.

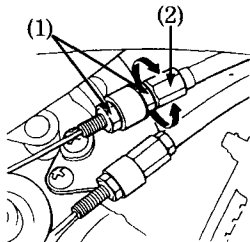

(1) Lock nuts

(2) Lower adjuster

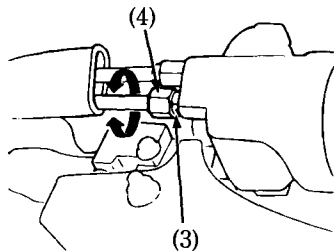

(3) Lock nut

(4) Upper adjuster

## IDLE SPEED

(Refer to the maintenance precautions on page 45).

The engine must be at normal operating temperature for accurate idle speed adjustment. Ten minutes of stop-and-go riding is sufficient.

### NOTE:

\* Do not attempt to compensate for faults in other systems by adjusting idle speed. See your authorized Honda dealer for regularly scheduled carburetor adjustments.

1. Warm up the engine, shift to neutral and place the motorcycle on its side stand.
2. Adjust idle speed with the throttle stop screw (1).

Idle speed: (In neutral)

$1,300 \pm 100 \text{ min}^{-1} (\text{rpm})$

$1,300 \pm 50 \text{ min}^{-1} (\text{rpm}) (\text{SW})$

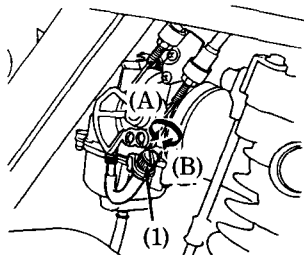

(1) Throttle stop screw

(A) Increase

(B) Decrease

## DRIVE CHAIN

(Refer to the maintenance precautions on page 45 ).

The service life of the drive chain is dependent upon proper lubrication and adjustment. Poor maintenance can cause premature wear or damage to the drive chain and sprockets.

The drive chain should be checked and lubricated as part of the Pre-ride Inspection (page 32 ). Under severe usage, or when the motorcycle is ridden in unusually dusty or muddy areas, more frequent maintenance will be necessary.

### Inspection:

1. Turn the engine off, raise the rear wheel off the ground by placing a support under the engine, and shift the transmission into neutral.
2. Check slack in the lower drive chain run midway between the sprockets. Drive chain slack should be adjusted to allow the following vertical movement by hand:

35—45 mm (1.2—1.8 in)

3. Roll the motorcycle forward. Stop. Check drive chain slack. Repeat this procedure several times. Drive chain slack should remain constant. If the chain is slack only in certain sections, some links are kinked and binding. Binding and kinking can frequently be eliminated by lubrication.

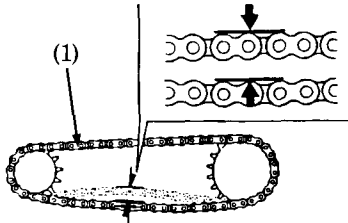

(1) Drive chain

4. Check the chain slider (2) for wear.  
When the thickness (3) of the chain slider reaches the limit, the chain slider (2) must be replaced.

Chain slider thickness limit:  
3 mm (0.12 in)

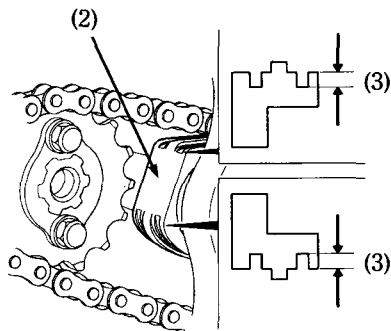

(2) Chain guide slider    (3) Thickness

5. Inspect the sprocket teeth for possible wear or damage. Replace if necessary.

Damaged Sprocket  
Teeth

Worn Sprocket  
Teeth

**REPLACE**

**REPLACE**

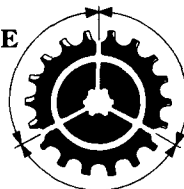

Normal Sprocket Teeth

**GOOD**

**NOTE:**

\* If the drive chain or sprockets are excessively worn or damaged, they should be replaced. Never use a new chain with worn sprockets; rapid chain wear will result.

### Adjustment:

Drive chain slack should be checked and adjusted, if necessary, every 1,000 km (600 miles). When operated at sustained high speeds or under conditions of frequent rapid acceleration, the chain may require more frequent adjustment.

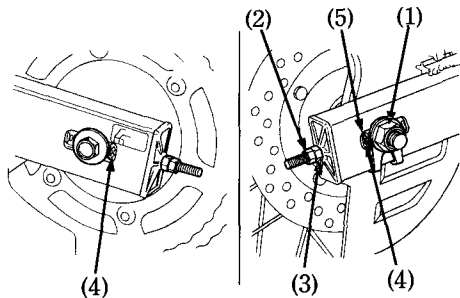

- (1) Axle nut
- (2) Lock nut
- (3) Drive chain adjusting nut

- (4) Index mark
- (5) Rear edge of adjusting slot

If the drive chain requires adjustment, the procedure is as follows:

1. Loosen the axle nut (1).
2. Loosen the lock nuts (2) on both adjusting nuts (3).
3. Turn both adjusting nuts (3) an equal number of turns until the correct drive chain slack is obtained. Turn the adjusting nuts clockwise to tighten the chain, or counterclockwise to provide more slack. Adjust the chain slack at a point midway between the drive sprocket and the rear wheel sprocket. Rotate the rear wheel and recheck slack at other sections of the chain.

Chain slack should be:

35—45 mm (1.2—1.8 in)

4. Check rear axle alignment by making sure the chain adjuster index marks (4) align with the rear edge (5) of the adjusting slots.

Both left and right marks should correspond. If the axle is misaligned, turn the left or right adjusting nut until the marks correspond on the rear edge of the adjusting slots and recheck chain slack.

5. Tighten the axle nut to:  
95 N·m (9.5 kg-m , 69 lb-ft)
6. Tighten the adjusting nuts lightly, then tighten the lock nuts by holding the adjusting nuts with a spanner.

#### Wear inspection:

Check the chain wear label when adjusting the chain. If the red zone (6) on the label aligns with the arrow mark (7) on the chain adjuster plates after the chain has been adjusted to the proper slack, the chain is excessively worn and must be replaced. The proper slack is:

35—45 mm (1.2—1.8 in)

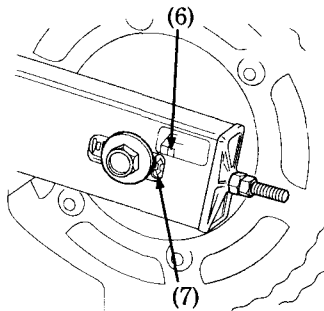

(6) Red zone

(7) Arrow mark

### Lubrication and cleaning:

Lubricate every 1,000 km (600 miles) or sooner if chain appears dry.

The O-rings in this chain can be damaged by steam cleaning, high pressure washers, and certain solvents. Clean the chain with high flash-point solvent, such as paraffin. Wipe dry and lubricate only with SAE 80 or 90 gear oil. Commercial chain lubricants may contain solvents which could damage the rubber O-rings.

Replacement Chain:

RK520SMO , DID520V6

### **CAUTION:**

**\* The drive chain on this motorcycle is equipped with small O-rings between the link plates. These O-rings retain grease inside the chain to improve its service life. However, special precautions must be taken when adjusting, lubricating, washing, and replacing the chain.**

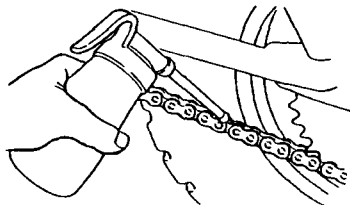

## FRONT AND REAR SUSPENSION

(Refer to the maintenance precautions on page 45).

### Front Suspension

Check the fork operation by locking the front brake and pumping the forks up and down several times. The suspension should function smoothly, with no oil leakage from the fork legs. Damaged, binding, or leaking fork should be repaired before the motorcycle is operated. Check security of all fork and handlebar mounting bolts (1).

#### **▲ WARNING**

**\* Operating the motorcycle with loose, worn, or damaged steering or front suspension components may adversely affect vehicle handling and stability.**

#### **▲ WARNING**

**\* If any suspension components appear worn or damaged, consult your authorized Honda dealer for further inspection. The suspension components are directly related to safety and your authorized Honda dealer is qualified to determine whether or not replacement parts or repairs are needed.**

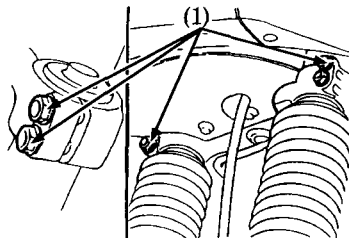

(1) Mounting bolts

## Rear Suspension

Check the rear suspension periodically by careful visual examination. Note the following items:

1. Swingarm bearings should be checked by pushing hard against the side of the rear wheel. Free play indicates worn bearings.
2. Check all suspension component attachment points for security of their respective fasteners.
3. Check for oil leaks in the shock absorber units.

### NOTE:

- \* If any of the mentioned components appear damaged or worn, consult your authorized Honda dealer for further inspection.

### **▲ WARNING**

- \* **The rear shock absorber assembly includes a damper unit that contains high pressure nitrogen gas. The instructions found in this owner's manual are limited to adjustment of the shock assembly only. Do not attempt to disassemble, disconnect or service the damper unit; an explosion causing serious injury may result.**
- \* **Puncture or exposure to flame may also result in an explosion, causing serious injury.**
- \* **Service or disposal should only be done by your authorized Honda dealer or a qualified mechanic, equipped with the proper tools, safety equipment and the official Honda Shop Manual.**

## SIDE STAND

(Refer to the maintenance precautions on page 45).

Perform the following maintenance in accordance with the maintenance schedule.

- Check the spring (1) for damage or loss of tension and the side stand assembly for freedom of movement.
- Check the side stand ignition cut-off system:
  1. Sit astride the motorcycle; put the side stand up and the transmission in neutral.
  2. Start the engine and with the clutch lever pulled in, shift the transmission into gear.
  3. Lower the side stand. The engine should stop as you put the side stand down.

If the side stand system does not operate as described, see your authorized Honda dealer for service.

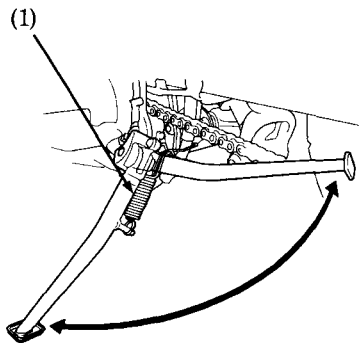

(1) Spring

## WHEEL REMOVAL

(Refer to the maintenance precautions on page 45).

### Front Wheel Removal

1. Raise the front wheel off the ground by placing a support under the engine.  
Remove the front fork cover (1) by removing the bolt and screw (2).
2. Remove the speedometer cable set screw (3) and disconnect the speedometer cable (4).
3. Remove the front axle holder nuts (5) and the front axle holder (6).
4. Unscrew the axle (7). Remove the wheel.

### NOTE:

\* Do not depress the brake lever when the wheel is off the motorcycle. The caliper piston will be forced out of the cylinder with subsequent loss of brake fluid. If this occurs, servicing of the brake system will be necessary. See your authorized Honda dealer for this service.

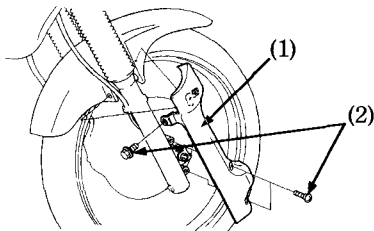

(1) Front fork cover (2) Bolt and screw

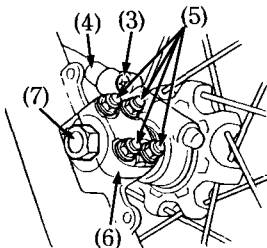

(3) Set screw (6) Axle holder  
(4) Speedometer cable (7) Axle  
(5) Axle holder nuts

### Installation Notes:

- Reverse the removal procedure.
- Insert the axle through the wheel hub and left fork leg.
- Make sure that the lug (8) on the speedometer gearbox is located behind the lug (9) on the right fork leg (10).
- Tighten the axle to the specified torque.

Front axle torque:

65 N·m (6.5 kg-m , 47 lb-ft)

- Install the axle holder with the UP mark (11) upward and tighten the upper holder nuts to the specified torque first, then tighten the lower holder nuts to the same torque.

Axle holder nut torque:

12 N·m (1.2 kg-m , 9 lb-ft)

- After installing the wheel, apply the brake several times and then check if the wheel rotates freely. Recheck the wheel if the brake drags or if the wheel does not rotate freely.

### **▲ WARNING**

- \* If a torque wrench was not used for installation, see your authorized Honda dealer as soon as possible to verify proper assembly. Improper assembly may lead to loss of braking capacity.

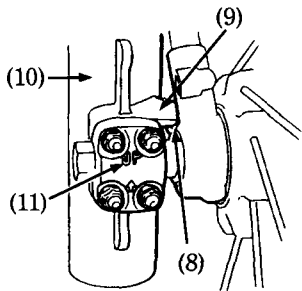

(8) lug  
(9) lug

(10) Right front fork  
(11) UP mark

## Rear Wheel Removal

1. Raise the rear wheel off the ground by placing a support block under the engine.
2. Loosen the drive chain adjusting nut lock nuts (1) and adjusting nuts (2).
3. Remove the rear axle nut (3).
4. Remove the drive chain (4) from the driven sprocket by pushing the rear wheel forward.

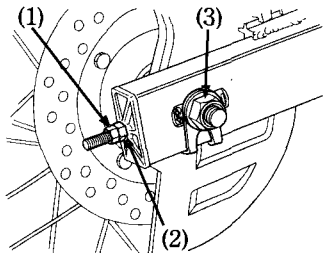

- (1) Lock nuts  
(2) Adjusting nuts

- (3) Axle nut

5. Remove the axle shaft (5), and rear wheel from the swingarm.

### NOTE:

- \* Do not depress the brake pedal while the wheel is off the motorcycle. The caliper piston will be forced out of the cylinder with subsequent loss of brake fluid. If this occurs, servicing of the brake system will be necessary. See your authorized Honda dealer for this service.

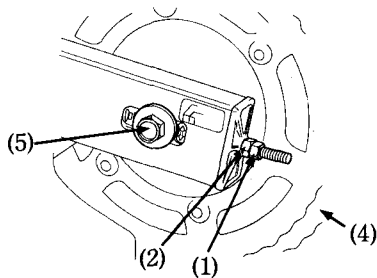

- (4) Drive chain

- (5) Axle shaft

### Installation Notes:

To install the rear wheel, reverse the removal procedure.

Torque the axle nut to the specified torque.

Axle nut torque:

95 N·m (9.5 kg-m , 69 lb-ft)

### **CAUTION:**

- \* **When installing the wheel carefully, fit the brake disc between the brake pads to avoid damaging the pads.**

After installing the wheel, apply the brake several times and then check if the wheel rotates freely. Recheck the wheel if the brake drags or if the wheel does not rotate freely.

### **▲ WARNING**

- \* **If a torque wrench was not used for installation, see your authorized Honda dealer as soon as possible to verify proper assembly. Improper assembly may lead to loss of braking capacity.**

## **BRAKE PAD WEAR**

(Refer to the maintenance precautions on page 45).

Brake pad wear depends upon the severity of usage, the type of riding, and road conditions. (Generally, the pads will wear faster on wet and dirty roads.)

Inspect the pads at each regular maintenance interval (page 41).

### **Front Brake**

Check the cutout (1) in each pad.

If either pad is worn to the cutout, replace both pads as a set. See your authorized Honda dealer for this service.

### **<FRONT BRAKE>**

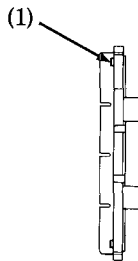
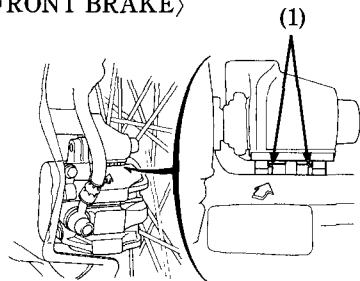

(1) Cutouts

## Rear Brake

Check the wear indicator mark (2) on each pad.

If either pad is worn to the wear indicator mark, replace both pads as a set. See your authorized Honda dealer for this service.

〈REAR BRAKE〉

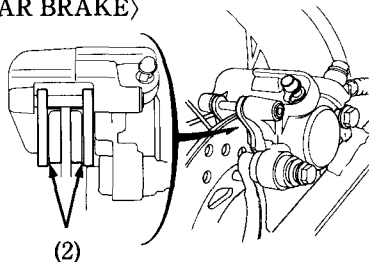

(2) Wear indicator marks

## **BATTERY**

(Refer to the maintenance precautions on page 45).

It is not necessary to check the battery electrolyte level or add distilled water as the battery is a maintenance-free (sealed) type. If your battery seems weak and/or is leaking electrolyte (causing hard starting or other electrical troubles), contact your authorized Honda dealer.

### **CAUTION:**

- \* Removing the battery caps can damage the caps and result in leaks and eventual battery damage.
- \* When the motorcycle is to be stored for an extended period of time, remove the battery from the motorcycle and charge it fully. Then store it in a cool, dry place. If the battery is to be left in the motorcycle, disconnect the negative cable from the battery terminal.

### **▲ WARNING**

- \* The battery gives off explosive gases; keep sparks, flames, and cigarettes away. Provide adequate ventilation when charging or using the battery in an enclosed space.
- \* The battery contains sulfuric acid (electrolyte). Contact with skin or eyes may cause severe burns. Wear protective clothing and a face shield.
  - If electrolyte gets on your skin, flush with water.
  - If electrolyte gets in your eyes, flush with water for at least 15 minutes and call a physician immediately.
- \* Electrolyte is poisonous.
  - If swallowed, drink large quantities of water or milk and follow with milk of magnesia or vegetable oil and call a physician.
- \* **KEEP OUT OF REACH OF CHILDREN.**

## FUSE REPLACEMENT

(Refer to the maintenance precautions on page 45).

The main fuse (2), located on the starter magnetic switch under the seat, is:

20A

The spare main fuse (3) is located under the starter magnetic switch.

The fuse box (5) is located lower the instruments. The specified fuses are:

10A, 15A

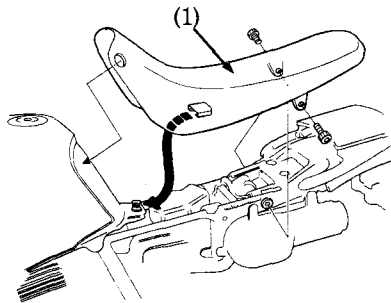

(1) Seat

74

When frequent fuse failure occurs, it usually indicates a short circuit or an overload in the electrical system. See your authorized Honda dealer for repair.

### CAUTION:

**\* Turn the ignition switch OFF before checking or replacing fuses to prevent accidental short-circuiting.**

The replace the main fuse (2), remove the side cover (page 46) and seat (1), disconnect the wire connector (4) of the starter magnetic switch and pull out the old fuse. Install a new fuse and reconnect the connector.

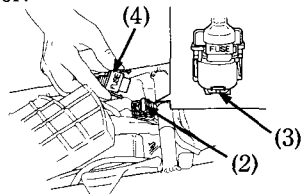

(2) Main fuse

(3) Spare main fuse

(4) Wire connector

To replace fuses in the fuse box, remove the panel (6) by removing the screws (7) and open the fuse box cover (8). Spare fuses (9) are located in the fuse box. Pull the old fuse out of the clips.

Push a new fuse into the clips and install the fuse box cover. Install the panel and tighten the screws.

**▲ WARNING**

**\* Never use a fuse with a different rating from that specified. Serious damage to the electrical system or a fire may result, causing a dangerous loss of lights or engine power.**

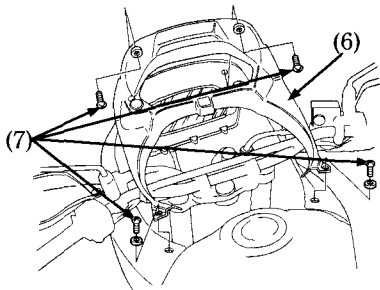

(6) Panel

(7) Screws

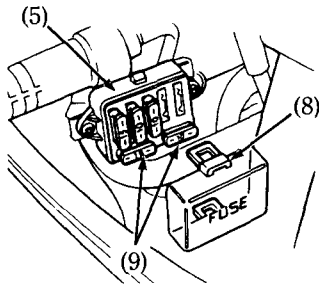

(5) Fuse box

(8) Fuse box cover

(9) Spare fuses

## STOPLIGHT SWITCH ADJUSTMENT

(Refer to the maintenance precautions on page 45 ).

Check the operation of the stoplight switch (1) at the right side behind the engine from time to time.

Adjustment is done by turning the adjusting nut (2). Turn the nut in the direction (A) if the switch operates too late and in direction (B) if the switch operates too soon.

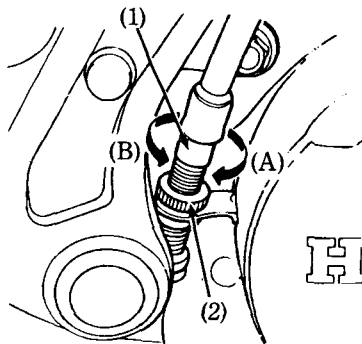

(1) Stoplight switch      (2) Adjusting nut

## CLEANING

Clean your motorcycle regularly to protect the surface finishes and inspect for damage, wear, and oil or brake fluid leakage.

### CAUTION:

**\* High pressure water (or air) can damage certain parts of the motorcycle.**

Avoid spraying high pressure water (typical in coin-operated car washes) at the following areas:

Wheel Hubs	Drive Chain
Muffler Outlets	Instruments
Under Fuel Tank	
Carburetor	
Under Seat	
Ignition Switch	
Steering Lock	
Brake Master Cylinder	

1. After cleaning, rinse the motorcycle thoroughly with plenty of clean water. Strong detergent residue can corrode alloy parts.

### NOTE:

\* Clean the plastic parts using a cloth or sponge dampened with a solution of mild detergent and water. Rub the soiled area gently rinsing it frequently with fresh water.

2. Dry the motorcycle, start the engine, and let it run for several minutes.
3. Lubricate the drive chain immediately after washing and drying the motorcycle.
4. Test the brakes before riding the motorcycle. Several applications may be necessary to restore normal braking performance.

### ▲ WARNING

**\* Braking efficiency may be temporarily impaired immediately after washing the motorcycle. Anticipate longer stopping distance to avoid a possible accident.**

## STORAGE GUIDE

Extended storage, such as for winter, requires that you take certain steps to reduce the effects of deterioration from non-use of the motorcycle. In addition, necessary repairs should be made **BEFORE** storing the motorcycle; otherwise, these repairs may be forgotten by the time the motorcycle is removed from storage.

### STORAGE

1. Change the engine oil and filter.
2. Lubricate the drive chain (page 63).
3. Drain the fuel tank and carburetors into an approved petrol container. Spray the inside of the tank with an aerosol rust-inhibiting oil.

Reinstall the fuel cap on the tank.

#### NOTE:

- \* If storage will last more than one month, carburetor draining is very important, to assure proper performance after storage.

#### **▲ WARNING**

**\* Petrol is extremely flammable and is explosive under certain conditions. Perform this operation in a well-ventilated area with the engine stopped. Do not smoke or allow flames or sparks in the area where petrol is drained or stored and where the fuel tank is refueled.**

4. Remove the spark plug and pour a tablespoon (15–20 cc) of clean engine oil into the cylinder. Operate the kickstarter several times to distribute the oil, then reinstall the spark plug.

#### NOTE:

- \* When turning the engine over, the engine Stop Switch should be OFF and each spark plug placed in its cable cap and grounded to prevent damage to the ignition system.

5. Remove the battery. Store in an area protected from freezing temperatures and direct sunlight.  
Slow charge the battery once a month.
6. Wash and dry the motorcycle. Wax all painted surfaces.
7. Inflate the tyres to their recommended pressures. Place the motorcycle on blocks to raise both tyres off the ground.
8. Cover the motorcycle (don't use plastic or other coated materials) and store in an unheated area, free of dampness with a minimum of daily temperature variation. Do not store the motorcycle in direct sunlight.

## **REMOVAL FROM STORAGE**

1. Uncover and clean the motorcycle.  
Change the engine oil if more than 4 months have passed since the start of storage.
2. Charge the battery as required. Install the battery.
3. Drain any excess aerosol rust-inhibiting oil from the fuel tank. Fill the fuel tank with fresh petrol.
4. Perform all Pre-ride Inspection checks (page 32 ).  
Test ride the motorcycle at low speeds in a safe riding area away from traffic.

# **SPECIFICATIONS**

## **DIMENSIONS**

Overall length	2,185 mm (86.0 in)
	2,195 mm (86.4 in) (IG, IIG, ND)
Overall width	890 mm (35.0 in)
Overall height	1,223 mm (48.1 in)
Wheelbase	1,442 mm (56.8 in)

## **WEIGHT**

Dry weight	152 kg (335 lbs)
------------	------------------

## **CAPACITIES**

Engine oil (After draining)	1.9 ℓ (2.0 US qt , 1.7 Imp qt)
(After disassembly)	2.3 ℓ (2.4 US qt , 2.0 Imp qt)
Fuel tank	16 ℓ (4.2 US gal , 3.5 Imp gal)
Fuel reserve	2.5 ℓ (0.66 US gal , 0.55 Imp gal)
Passenger capacity	Operator and one passenger
Maximum weight capacity	180 kg (396 lbs)

## ENGINE

Bore and stroke	100 x 82 mm (3.9 x 3.2 in) 92 x 75 mm (3.6 x 3.0 in) (AR)
Compression ratio	8.3 : 1 8.9 : 1 (AR)
Displacement	644 cm <sup>3</sup> (39.3 cu-in) 498 cm <sup>3</sup> (30.4 cu-in) (AR)
Spark plug Standard	DPR8EA—9 (NGK) or X24EPR—U9 (NIPPONDENSO)
For cold climate (Below 5°C, 41°F)	DPR7EA—9 (NGK) or X22EPR—U9 (NIPPONDENSO)
For extended high speed riding	DPR9EA—9 (NGK) or X27EPR—U9 (NIPPONDENSO)
Spark plug gap	0.80—0.90 mm (0.031—0.035 in)
Idle speed	1,300 ± 100 min <sup>-1</sup> (rpm) 1,300 ± 50 min <sup>-1</sup> (rpm) (SW)

## CHASSIS AND SUSPENSION

Caster	28° 30'
Trail	115 mm (4.5 in)
Tyre size, front	90/90—21 54S
Tyre size, rear	120/90—17 64S

## **POWER TRANSMISSION**

Primary reduction	2.029
	2.1875 (AR)
Gear ratio, 1st	2.666
2nd	1.750
	1.647 (AR)
3rd	1.250
4th	1.000
5th	0.800
	0.840 (AR)
Final reduction	3.000 (SW)
	2.9333 (AR)
	3.133 (E, F, IG, IIG, SP, ED, ND, BR)

## **ELECTRICAL**

Battery	12V – 8AH
Generator	0.18 kw/5,000 min <sup>-1</sup> (rpm)

## LIGHTS

Headlight (HIGHT/LOW)		12V — 60/55W
Tail/brake light		12V — 5/21W
Turn signal light	Front	12V — 21W x 2
	Rear	12V — 21W x 2
Instrument lights		12V — 1.7W x 4
Neutral indicator light		12V — 3.4W
Turn signal indicator		12V — 3.4W x 2
High beam indicator		12V — 1.7W
Side stand indicator		12V — 3.4W
Position light		12V — 4W
		12V — 3.4W (E)

## FUSE

10A, 15A  
20A (Main fuse)

## **NOISE CONTROL SYSTEM (AUSTRALIA ONLY)**

**TAMPERING WITH THE NOISE CONTROL SYSTEM IS PROHIBITED:** Owners are warned that the law may prohibit : (a) The removal or rendering inoperative by any person other than for purposes of maintenance, repair, or replacement, of any device or element of design incorporated into any new vehicle for the purpose of noise control prior to its sale or delivery to the ultimate purchaser or while it is in use; and (b) the use of the vehicle after such device or element of design has been removed or rendered inoperative by any person.