

 **HONDA**

# OWNER'S MANUAL

READ THIS MANUAL CAREFULLY,  
IT CONTAINS IMPORTANT SAFETY INFORMATION.



MINIMALI BELZIMVAG-CED OPERATOR AGE 16

**TRX450R/ER**

This manual should be considered a permanent part of the ATV and should remain with the ATV when it is resold.

This Owner's Manual covers the TRX450ER (electric starter) and TRX450R (kickstarter) models. You may find descriptions of equipment and features that are not on your particular model. All illustrations are based on the TRX450ER model.

This publication includes the latest production information available before printing. Honda Motor Co., Ltd. reserves the right to make changes at any time without notice and without incurring any obligation.

No part of this publication may be reproduced without written permission.

© Honda Motor Co., Ltd. 2008

**Honda TRX450ER (electric starter)**  
**Honda TRX450R (kickstarter)**  
**OWNER'S MANUAL**

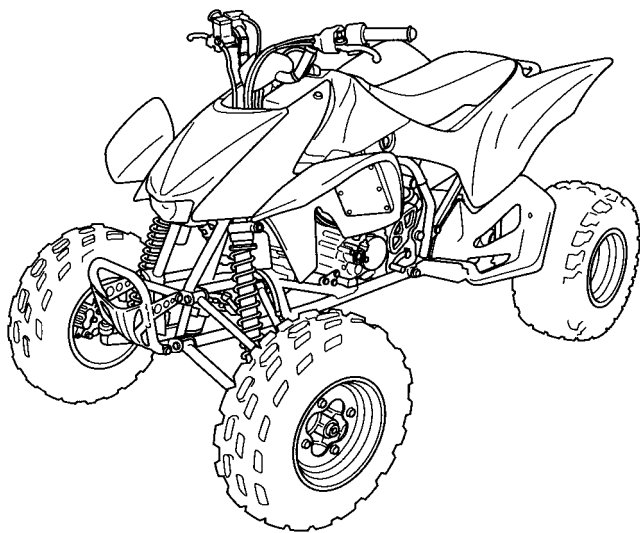

# Introduction

---

Congratulations on choosing your Honda ATV.

When you own a Honda, you're part of a worldwide family of satisfied customers — people who appreciate Honda's reputation for building quality into every product.

Your Honda was designed as a recreational ATV for off-road use by one rider only.

Before riding, take time to get acquainted with your ATV and how it works. To protect your investment, we urge you to take responsibility for keeping your ATV well maintained. Scheduled service is a must, of course. But it's just as important to observe the break-in guidelines, and perform all pre-ride and other periodic checks detailed in this manual.

We also recommend that you read this owner's manual before you ride. It's full of facts, instructions, safety information, and helpful tips. To make it easy to use, the manual contains a detailed list of topics at the beginning of each section, and both an in-depth table of contents and an index at the back of the book.

As you read this manual, you will find information that is preceded by a **NOTICE** symbol. This information is intended to help you avoid damage to your Honda, other property, or the environment.

Whenever you ride, tread lightly. By staying on established trails and riding only in approved areas, you help protect the environment and keep off-road riding areas open for the future.

# Introduction

---

If you have any questions, or if you ever need special service or repairs, remember that your Honda dealer knows your ATV best and is dedicated to your complete satisfaction.

Happy riding!

# A Few Words About Safety

---

Your safety, and the safety of others, is very important. And operating this ATV safely is an important responsibility.

To help you make informed decisions about safety, we have provided operating procedures and other information on labels and in this manual. This information alerts you to potential hazards that could hurt you or others.

Of course, it is not practical or possible to warn you about all hazards associated with operating or maintaining an ATV. You must use your own good judgment.

You will find important safety information in a variety of forms, including:

**Safety Labels** — on the ATV.

**Safety Messages** — preceded by a safety alert symbol  and one of three signal words: **DANGER**, **WARNING**, or **CAUTION**.

# A Few Words About Safety

---

These signal words mean:

**▲ DANGER**

You **WILL** be **KILLED** or **SERIOUSLY HURT** if you don't follow instructions.

**▲ WARNING**

You **CAN** be **KILLED** or **SERIOUSLY HURT** if you don't follow instructions.

**▲ CAUTION**

You **CAN** be **HURT** if you don't follow instructions.

**Safety Headings** — such as Important Safety Reminders or Important Safety Precautions.

**Safety Section** — such as ATV Safety.

**Instructions** — how to use this ATV correctly and safely.

This entire manual is filled with important safety information — please read it carefully.

# Contents

---

These pages give an overview of the contents of your owner's manual. The first page of each section lists the topics covered in that section.

<b>ATV Safety .....</b>	<b>1</b>
Important safety information you should know, plus a look at the safety related labels on your ATV.	
<b>Indicators &amp; Controls .....</b>	<b>9</b>
The location and function of indicators and controls on your ATV and operating instructions for various controls and features.	
<b>Before Riding.....</b>	<b>27</b>
The importance of wearing a helmet and other protective gear, how to make sure you and your ATV are ready to ride, and important information about loading.	
<b>Basic Operation &amp; Riding .....</b>	<b>41</b>
How to start and stop the engine, shift gears, and brake. Also, riding precautions.	

# Contents

---

<b>Servicing Your Honda</b> .....	<b>73</b>
Why your ATV needs regular maintenance, what you need to know before servicing your Honda, an owner maintenance schedule, and instructions for specific maintenance and adjustment items.	
<b>Tips</b> .....	<b>169</b>
How to store and transport your ATV and how to be an environmentally responsible rider.	
<b>Taking Care of the Unexpected</b> .....	<b>179</b>
What to do if you have a flat tyre, your engine won't start, etc.	
<b>Technical Information</b> .....	<b>197</b>
ID numbers, technical specifications, and other technical facts.	
<b>Table of Contents</b> .....	<b>208</b>
Sequential listing of topics in this owner's manual.	
<b>Index</b> .....	<b>214</b>
<b>Manufacturer and Authorised Representative for EU Market</b> ....	<b>227</b>



# ATV Safety

---

This section presents some of the most important information and recommendations to help you ride your ATV safely. Please take a few moments to read these pages. This section also includes information about the location of safety labels on your ATV.

Important Safety Information .....	2
Safety Labels.....	5

# **Important Safety Information**

---

Your ATV can provide many years of service and pleasure if you take responsibility for your own safety and understand the challenges you can meet while riding.

There is much that you can do to protect yourself when you ride. You'll find many helpful recommendations throughout this manual. The following are a few that we consider to be most important.

## **Follow the Age Recommendation**

The minimum recommended age for this ATV model is 16. Children under age 16 should never operate this vehicle.

## **Always Wear a Helmet**

It's a proven fact: helmets significantly reduce the number and severity of head injuries. So always wear an approved motorcycle helmet. We also recommend that you wear eye protection, sturdy boots, gloves, and other protective gear (page 28 ).

## **Never Carry a Passenger**

Your ATV is designed for one person only. There are no handholds, footrests, or seat for a second person, so never carry a passenger. A passenger could interfere with your ability to move around to maintain your balance and control of the ATV.

# Important Safety Information

---

## **Ride Off-road Only**

Your ATV is designed and manufactured for off-road use only. The tyres are not made for pavement, and the ATV does not have turn signals and other features required for use on public roads. If you need to cross a paved or public road, get off and walk your ATV across.

## **Take Time to Learn & Practice**

Even if you have ridden other ATVs, take time to become familiar with how this ATV works and handles. Practice in a safe area until you build your skills and get accustomed to the ATV's size and weight.

## **Be Alert for Off-road Hazards**

The terrain can present a variety of challenges when you ride off-road. Continually “read” the terrain for unexpected turns, drop-offs, rocks, ruts, and other hazards. Always keep your speed low enough to allow time to see and react to hazards.

# Important Safety Information

---

## **Ride within Your Limits**

Pushing limits is another major cause of ATV accidents. Never ride beyond your personal abilities or faster than conditions warrant. Remember that alcohol, drugs, fatigue, and inattention can significantly reduce your ability to make good judgments and ride safely.

## **Don't Drink and Ride**

Alcohol and riding don't mix. Even one drink can reduce your ability to respond to changing conditions, and your reaction time gets worse with every additional drink. So don't drink and ride, and don't let your friends drink and ride either.

## **Keep Your Honda in Safe Condition**

It's important to keep your ATV properly maintained and in safe riding condition. Having a breakdown can be difficult, especially if you are stranded off-road far from your base. To help avoid problems, inspect your ATV before every ride and perform all recommended maintenance.

# Safety Labels

---

Your ATV comes with several labels containing important safety information. Anyone who rides the vehicle should read and understand this information before riding.

The labels should be considered permanent parts of the vehicle. If a label comes off or becomes hard to read, contact your Honda dealer for replacements.

# Safety Labels

---

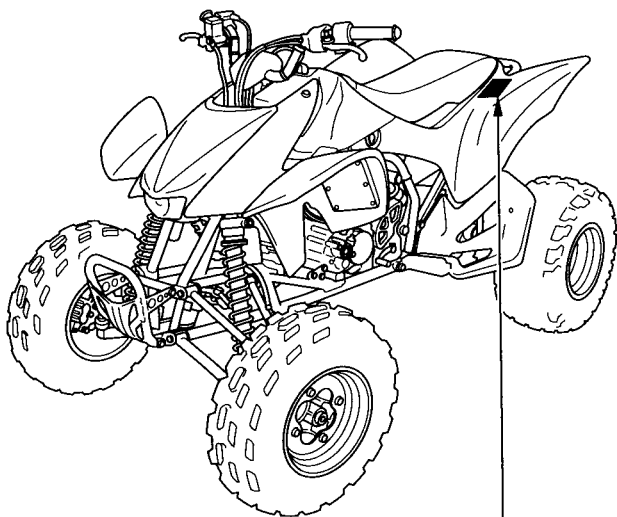

**⚠ WARNING**

Improper tire pressure or overloading can cause loss of control. Loss of control can result in severe injury or death.

- Cold tire pressure :  
Front : 4.0psi (27.5kPa)  
Rear : 4.7psi (32.5kPa)
- Maximum weight capacity : 243lbs.(110kg)

# Safety Labels





**WARNING**

The improper operation of ATVs may result in severe injury or death.

- Read the Owner's Manual.
- Follow all warnings and instructions.
- Never use without proper training and instruction.

While riding:

- Never ride too fast for your skills or the conditions.
- Always use proper riding techniques for hills, slopes, and rough terrain.
- Use care when changing riding surfaces. ATVs handle differently on different surfaces, such as sand, dirt, or pavement.

-  Never carry a passenger, since it would affect balance and steering and may cause you to lose control.
-  Avoid operating on public roads, since a collision can occur with another vehicle.
-  Never ride after drinking alcohol or using drugs.
-  Always wear a helmet, eye protection, and protective gear.

**WARNING**



Operating this ATV if you are under the age of 16 increases your chance of severe injury or death.

NEVER operate this ATV if you are under age 16.

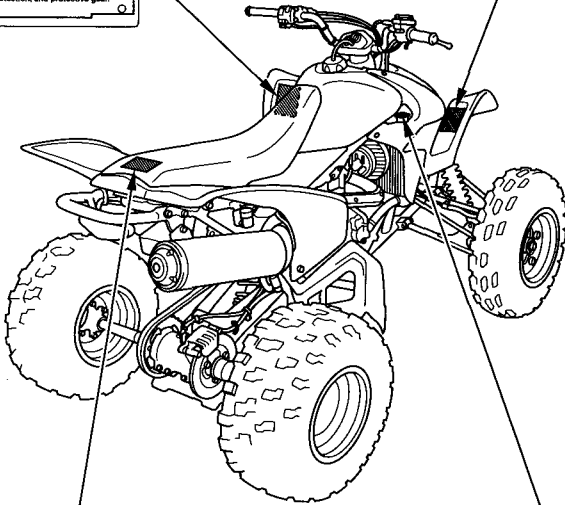

**WARNING**



**NEVER** ride as a passenger. Passengers can cause a loss of control, resulting in SEVERE INJURY or DEATH.

**DANGER**  
**WARNING**  
危険

▶ NEVER OPEN WHEN HOT.  
Hot coolant will scald you.  
▶ N' OUVREZ PAS QUAND CHAUD.  
▶ NICHT BEI HEISSEM MOTOR OFFENEN.  
▶ 熱い時蓋をあけないで下さい。  
▶ 高温時、蓋物打开

1.1

# Safety Labels

---

TRX450ER

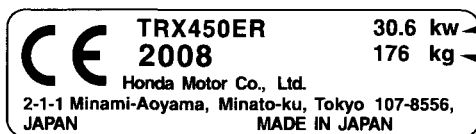

Engine net power

Machine mass

TRX450R

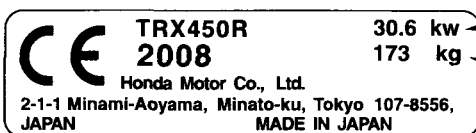

Engine net power

Machine mass

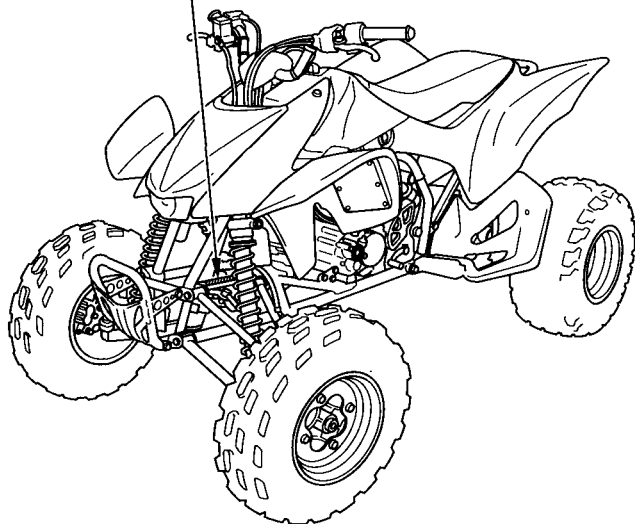

# Indicators & Controls

---

This section shows the location of all indicators and controls you would normally use before or while riding your ATV.

The items listed on this page are described in this section. Instructions for other components are presented in other sections of this manual where they will be most useful.

Operation Component Locations .....	10
Indicators.....	13
High Coolant Temperature Indicator .....	13
Neutral Indicator ( TRX450ER only).....	14
Controls & Features .....	15
Fuel Valve .....	15
Choke Knob .....	16
Hot Start Lever ( TRX450R only).....	17
Ignition Switch.....	18
Start Button ( TRX450ER only).....	19
Kickstarter ( TRX450R only) .....	20
Engine Stop Switch .....	21
Headlight Switch.....	22
Headlight Dimmer Switch.....	22
Throttle Lever .....	23
Clutch Lever/Parking Brake Lever .....	23
Front Brake Lever .....	24
Rear Brake Pedal.....	24
Parking Brake.....	25
Flag Pole Bracket .....	26

# Operation Component Locations

---

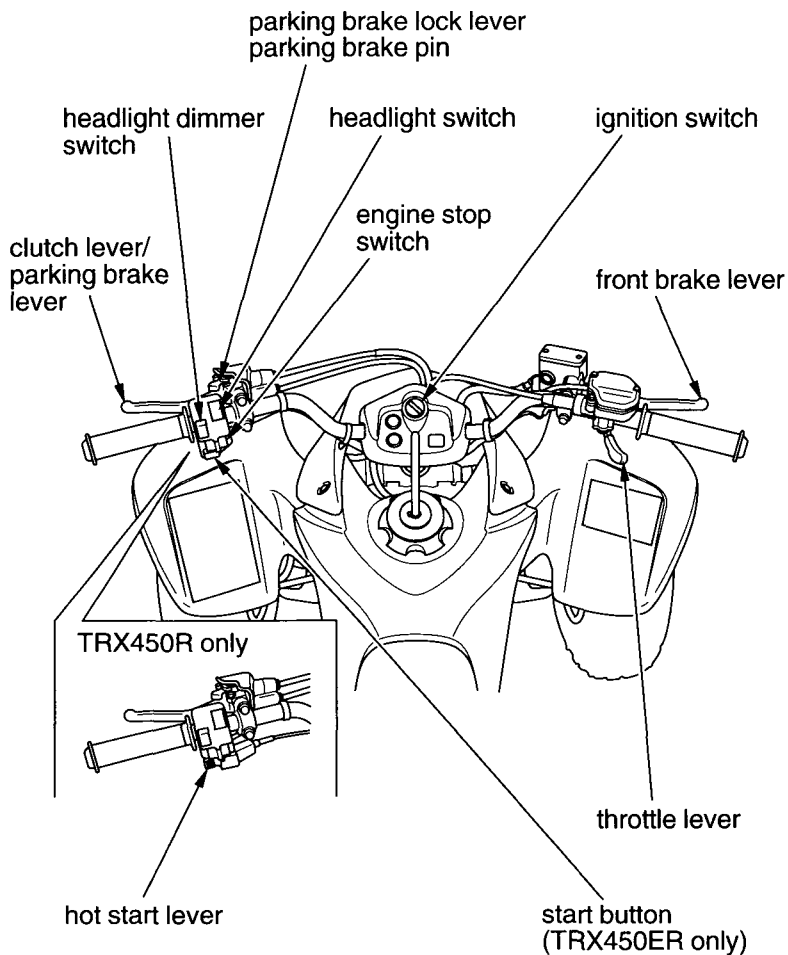

# Operation Component Locations

---

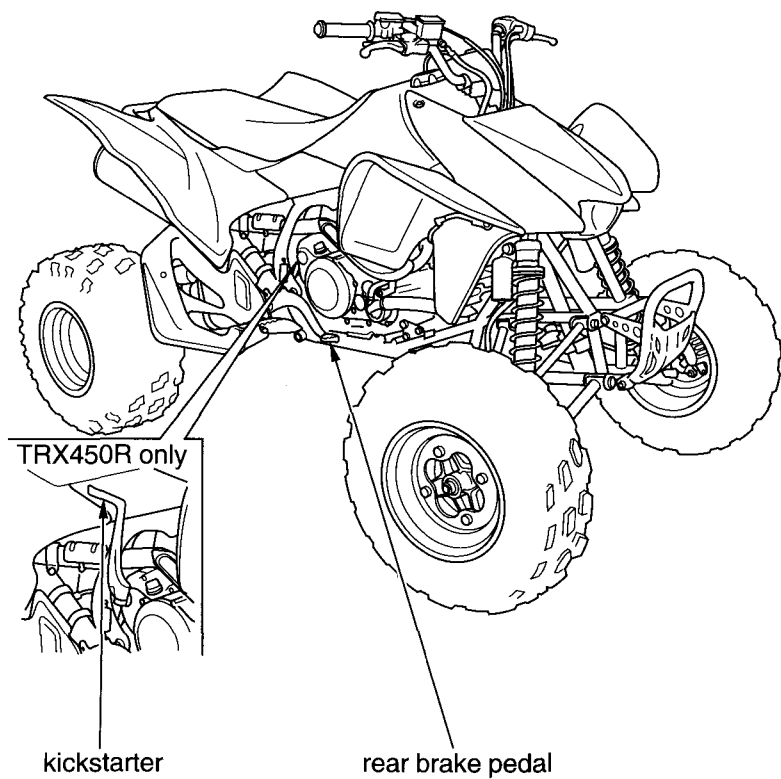

# Operation Component Locations

---

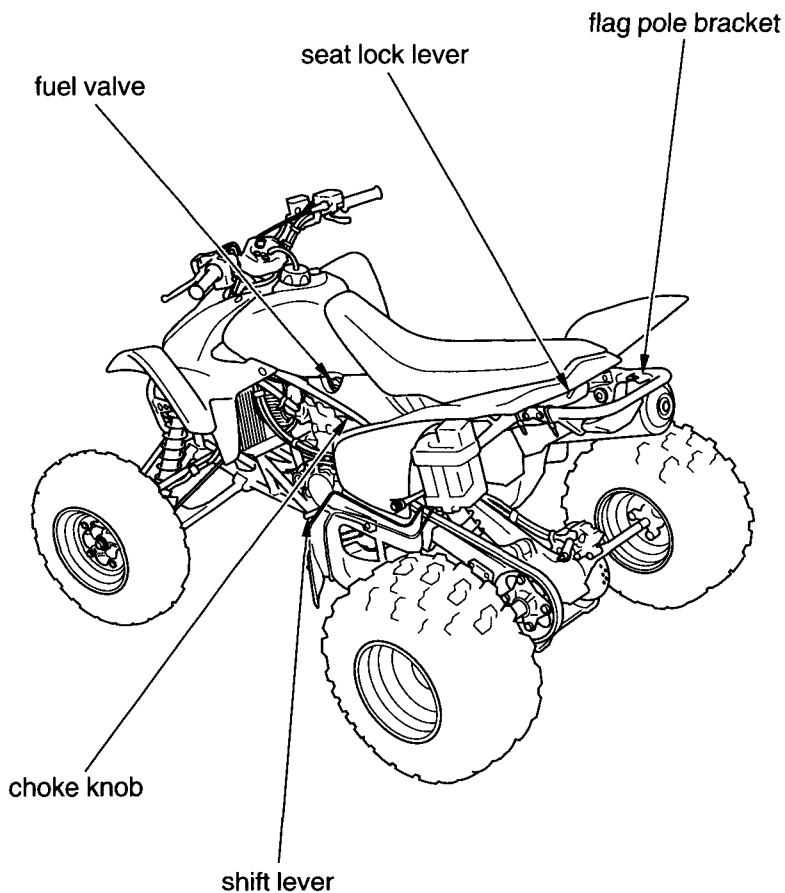

# Indicators

## High Coolant Temperature Indicator

CENTRE OF HANDLEBAR

TRX450ER

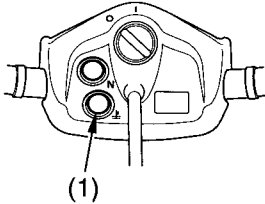

TRX450R

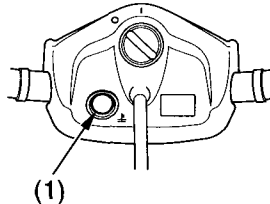

(1) high coolant temperature indicator

Lights when the engine coolant temperature is high enough to adversely affect the service life of the engine.

If the high coolant temperature indicator (1) comes on while you are riding, immediately bring the vehicle to a stop, turn the engine off and let it cool. See page 189.

### Lamp Check (TRX450ER)

The high coolant temperature indicator comes on for a few seconds and then goes off when you turn the ignition switch to ON ( I ).

### (TRX450R)

The engine is started when you operate the kickstarter, you can see the indicator comes on at the same time. If the engine is running, the indicator will go off after a few seconds. If the engine is stopping, the indicator will go off at the same time.

If the indicator does not come on when it should, have your Honda dealer check for a burned-out bulb or other problems.

# Indicators

---

## Neutral Indicator (TRX450ER only)

CENTRE OF HANDLEBAR

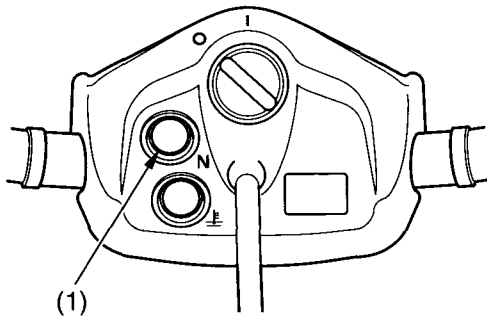

(1) neutral indicator

The neutral indicator will light when the transmission is in neutral and the ignition switch is ON ( I ).

If the indicator does not come on when it should, have your Honda dealer check for a burned-out bulb or other problems.

# Controls & Features

## Fuel Valve

### LEFT SIDE

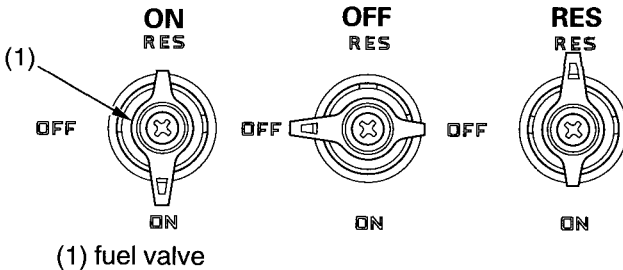

The manual fuel valve (1) is located on the left side under the fuel tank.

The three-way fuel valve is used to control the flow of fuel from the fuel tank to the carburetor.

ON – normal position for riding.

OFF – for parking, storing, or transportation.

RES – for extra fuel to get to a gas supply for refueling.

### Reserve Fuel

Remember to check that the fuel valve is in the ON position each time you refuel. If the fuel valve is left in the RES position, you may run out of fuel with no reserve.

For complete information about fueling your ATV, see page 89 .

# Controls & Features

## Choke Knob



LEFT SIDE

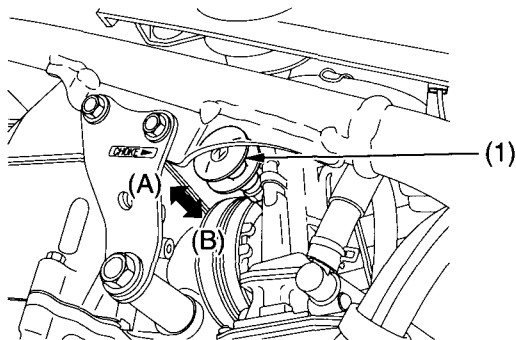

(1) choke knob

(A) fully ON

(B) fully OFF

The choke knob (1) may be used when starting the engine.  
See page 50 .

# Controls & Features

---

## Hot Start Lever ( TRX450R only)

### LEFT HANDLEBAR

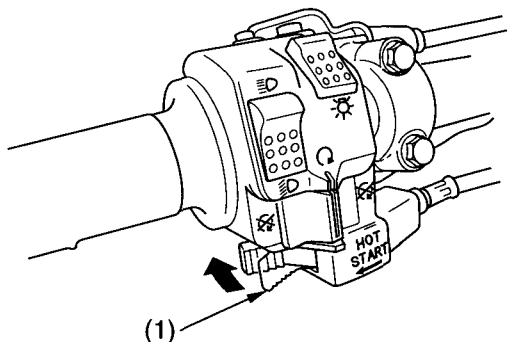

(1) hot start lever

The hot start lever (1) may be used when starting a warm engine. See page 53.

# Controls & Features

---

## Ignition Switch

The ignition switch (1) is used for starting and stopping the engine (page 47). Insert the key and turn it to the right for the ON ( I ) position.

Key Position	Function
ON ( I )	Electrical circuits on.
OFF ( O )	No electrical circuits function.

### CENTRE OF HANDLEBAR

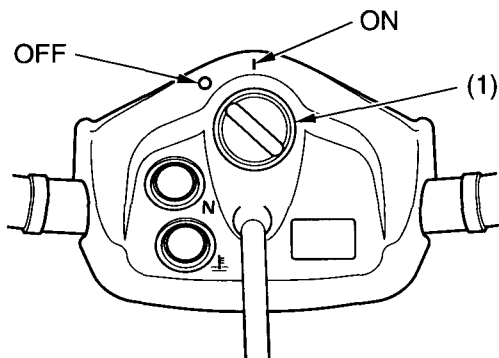

(1) ignition switch

I ON  
O OFF

# Controls & Features

## Start Button (TRX450ER only)



### LEFT HANDLEBAR

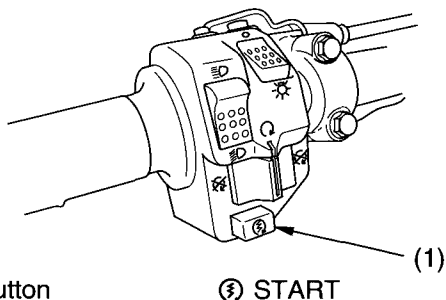

The start button (1) is used for starting the engine. Pushing the button in starts the engine. See *Starting Procedure*, page 50 .

When the start button is pushed, the starter motor will crank the engine. The starter motor will operate even if the engine stop switch is in the OFF (  ) position when the start button is pushed.

# Controls & Features

---

## Kickstarter ( TRX450R only)

RIGHT SIDE

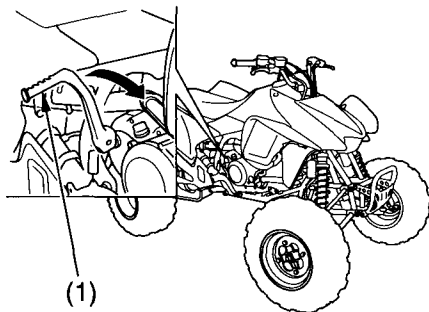

(1) kickstarter

The kickstarter ( 1 ) is used to start the engine. To operate, swing the kickstarter out from its stored position and depress it through its entire stroke. See Starting Procedure, page 51 .

# Controls & Features

## Engine Stop Switch



LEFT HANDLEBAR

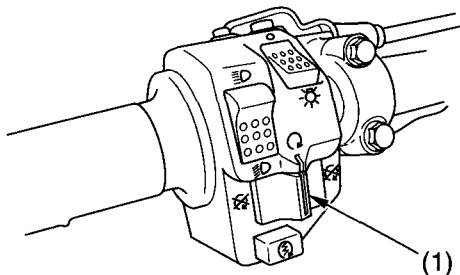

(1) engine stop switch

○ RUN  
⊗ OFF

The engine stop switch (1) is used to stop the engine in an emergency. To operate, slide the switch to the OFF (⊗) position. The switch must be in the RUN (○) position to start the engine, and it should normally remain in the RUN (○) position even when the engine is OFF.

(TRX450ER only)

If your ATV is stopped with the ignition switch ON ( I ) and the engine stop switch OFF ( ⊗ ), the battery will discharge. Turn the ignition switch OFF ( ○ ) to prevent battery discharge.

# Controls & Features

## Headlight Switch



LEFT HANDLEBAR

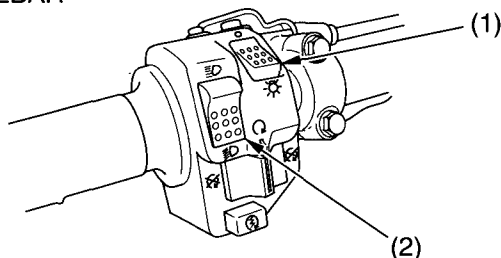

(1) headlight switch

(2) headlight dimmer switch

- OFF
- ☀ ON
- ≡D HI
- ≡D LO

The headlight switch (1) is used to turn the headlight ON (☀) or OFF (●). To operate, turn the switch to ON (☀) or OFF (●).

## Headlight Dimmer Switch



The headlight dimmer switch (2) is used to change between the high and low beams of the headlight. To operate, turn the switch to HI (≡D) for high beam, LO (≡D) for low beam.

# Controls & Features

## Throttle Lever

### RIGHT HANDLEBAR

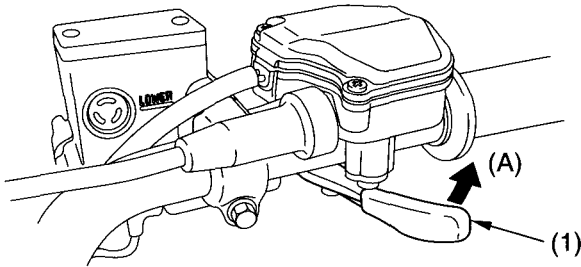

(1) throttle lever

(A) to open the throttle

The throttle controls engine rpm (speed). To increase engine rpm, press the throttle lever ( 1 ) with your thumb. To reduce engine rpm, release pressure on the throttle lever. The throttle will automatically return to the closed position (engine idle) when you remove your thumb.

## Clutch Lever/Parking Brake Lever

The clutch lever/parking brake lever is used to disengage the clutch whenever you shift gears. To operate, pull the clutch lever/parking brake lever in all the way before shifting, then slowly release it after shifting. See *Clutch System*, page 116 .

# Controls & Features

---

## Front Brake Lever

The front brake lever is used to slow or stop your ATV. To operate, pull the lever. For information on braking techniques, see page 58 .

## Rear Brake Pedal

The rear brake pedal is used to slow or stop your ATV. To operate, depress the pedal. For information on braking techniques, see page 58 .

# Controls & Features

## Parking Brake

### LEFT HANDLEBAR

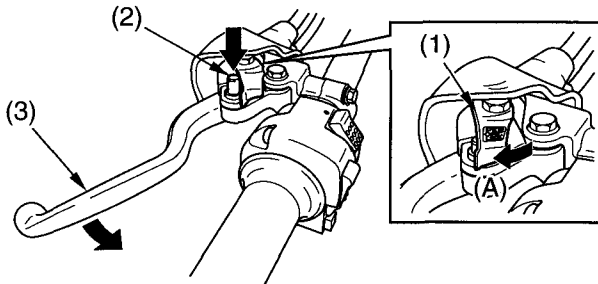

(1) lock lever  
(2) parking brake pin

(3) clutch lever/  
parking brake lever  
(A) to lock

The lock lever (1) and parking brake pin (2) on the clutch lever/parking brake lever (3) allows it to be used as a parking brake. To operate, push down and hold the parking brake pin, squeeze the clutch lever/parking brake lever and then lock it with the lock lever. See *Parking* page 72 .

To release the parking brake, squeeze the clutch lever/parking brake lever.

# Controls & Features

---

## Flag Pole Bracket

RIGHT REAR

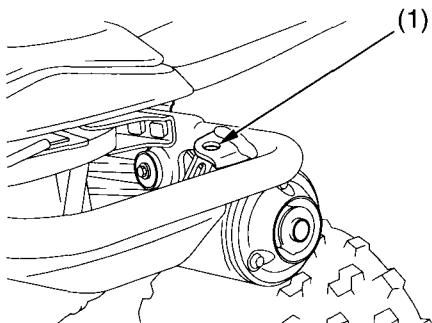

(1) flag pole bracket

Flag poles are optional equipment available from your Honda dealer. To mount a pole in the bracket ( 1 ), follow the instructions that come with the flag pole kit.

Flag poles are required in some riding areas. Check local regulations before riding.

# Before Riding

---

Before each ride, you need to make sure you and your Honda are both ready to ride. To help get you prepared, this section discusses how to evaluate your riding readiness, what items you should check on your ATV, and adjustments to make for your comfort, convenience, or safety. This section also includes important information about loading.

Are You Ready to Ride? .....	28
Protective Apparel .....	28
Rider Training .....	30
Age Recommendation .....	31
No Passengers .....	31
No Alcohol or Drugs .....	32
Is Your ATV Ready to Ride? .....	33
Pre-ride Inspection .....	33
Load Limits & Guidelines .....	36
Loading .....	36
Load Limits .....	37
Loading Guidelines .....	38
Accessories & Modifications .....	39
Accessories .....	39
Modifications .....	40

# Are You Ready to Ride?

---

Before you ride your ATV for the first time, we urge you to:

- Read this owner's manual and the labels on your ATV carefully.
- Make sure you understand all the safety messages.
- Know how to operate all the controls.

Before each ride, be sure:

- You feel well and are in good physical and mental condition.
- You are wearing an approved motorcycle helmet (with chin strap tightened securely), eye protection, and other protective clothing.
- You don't have any alcohol or drugs in your system.

## Protective Apparel

For your safety, we strongly recommend that you always wear an approved motorcycle helmet, eye protection, boots, gloves, long pants, and a long-sleeved shirt or jacket whenever you ride.

Although complete protection is not possible, wearing proper gear can reduce the chance of injury when you ride.

Following are suggestions to help you choose the proper gear.

### Helmets and Eye Protection

Your helmet is your most important piece of riding gear because it offers the best protection against head injuries. A helmet should fit your head comfortably and securely.

# Are You Ready to Ride?

---

An open-face helmet offers some protection, but a full-face helmet offers more. Always wear a face shield or goggles to protect your eyes and help your vision.

## **WARNING**

Operating this ATV without wearing an approved motorcycle helmet, eye protection, and protective clothing could increase your chances of severe injury or death in the event of an accident.

Always wear an approved motorcycle helmet that fits properly and wear eye protection (goggles or face shield), gloves, boots, long-sleeved shirt or jacket and long pants.

### Additional Riding Gear

In addition to a helmet and eye protection, we also recommend:

- Sturdy off-road motorcycle boots to help protect your feet, ankles, and lower legs.
- Off-road motorcycle gloves to help protect your hands.
- Riding pants with knee and hip pads, a riding jersey with padded elbows, and a chest/shoulder protector.

# Are You Ready to Ride?

---

## Rider Training

Developing your riding skills is an on-going process. Even if you have ridden other ATVs, take time to become familiar with how this ATV works and handles. Practice riding the ATV in a safe area to build your skills. Do not ride in rough terrain until you get accustomed to the ATV's controls, and feel comfortable with its size and weight.

### **⚠ WARNING**

Operating this ATV without proper instruction could increase your risk of an accident which could lead to serious injury or death.

Beginning and inexperienced operators should complete the certified training course offered by Honda. They should then regularly practice the skills learned in the course and the operating techniques described in the owner's manual.

# Are You Ready to Ride?

---

## Age Recommendation

The minimum recommended age for this ATV model is 16. For safety, never let children under 16 years old operate this vehicle.

### **⚠ WARNING**

A child using an ATV that is not recommended for their age could lose vehicle control while riding, resulting in severe injury or death.

A child under 16 should never operate an ATV with engine size greater than 90cc.

## No Passengers

This ATV is designed as an operator-only vehicle. The long seat is designed to allow the rider to change body position, not for carrying a passenger. Never let a passenger ride on the seat.

### **⚠ WARNING**

Carrying a passenger on this ATV greatly reduces your ability to balance and control this ATV and could cause a crash and you or your passenger could be injured or killed.

Never carry a passenger on this ATV.

# Are You Ready to Ride?

---

## No Alcohol or Drugs

Alcohol, drugs and ATVs don't mix. Even a small amount of alcohol can impair your ability to operate an ATV safely. Likewise, drugs — even if prescribed by a physician — can be dangerous while operating an ATV. Consult your doctor to be sure it is safe to operate a vehicle after taking medication.

### **WARNING**

Operating this ATV after consuming alcohol or drugs can seriously affect your judgement, cause you to react more slowly, affect your balance and perception, and result in serious injury or death.

Never consume alcohol or drugs before or while operating this ATV.

# Is Your ATV Ready to Ride?

Before each ride, it's important to inspect your ATV and make sure any problem you find is corrected. A pre-ride inspection is a must, not only for safety, but because having a breakdown, or even a flat tyre, can be a major inconvenience.

If your ATV has overturned or been involved in a collision, do not ride the vehicle until it has been inspected by your Honda dealer. There may be damage or other problems you cannot see.

## **⚠ WARNING**

Improperly maintaining this ATV or failing to correct a problem before riding can cause a crash in which you can be seriously hurt or killed.

Always perform a pre-ride inspection before every ride and correct any problems.

### **Pre-ride Inspection**

Check the following items before you get on the ATV:

*Engine Oil*                      Check the level and add oil if needed (page 95 ).  
Check for leaks.

*Transmission Oil*              Check the level and add oil if needed (page 101 ).  
Check for leaks.

*Radiator Coolant*              Check the coolant level and add coolant if needed  
(page 105 ).  
Check for leaks.

# Is Your ATV Ready to Ride?

---

<i>Fuel</i>	Check the level and add fuel (page 90 ) if needed. Also make sure the fuel fill cap is securely fastened. Check for leaks.
<i>Tyres</i>	Use a gauge to check the air pressure. Adjust if needed. Also look for signs of damage or excessive wear (page 144 ).
<i>Drive Chain</i>	Check the condition and slack. Adjust and lubricate if needed. Also check the chain slider and chain roller for wear and replace if needed (page 152 ).
<i>Nuts &amp; Bolts</i>	Check the wheels to see that the axle nuts are tightened. Use a wrench to make sure all accessible nuts, bolts, and fasteners are tight.
<i>Underbody &amp; Exhaust System</i>	Check for, and remove, any dirt, vegetation or other debris that could be a fire hazard or interfere with the proper operation of the vehicle.
<i>Leaks, Loose Parts</i>	Walk around your ATV and look for anything that appears unusual, such as a leak or loose cable.
<i>Cable</i>	Check the cable housings for wear. Check the fittings for looseness. Replace or tighten as needed.
<i>Lights</i>	Make sure the headlight, brakelight and taillight are working properly.

# Is Your ATV Ready to Ride?

---

Check these items after you get on the ATV:

*Throttle* Check the freeplay and adjust if needed. Press the throttle to make sure it moves smoothly without sticking, and snaps shut automatically when it is released, in all steering positions (page 114 ).

*Brakes* Squeeze the front brake lever and step on the rear brake pedal to check that the controls operate normally. Make sure there is no brake fluid leakage (page 135 ).

*Clutch Lever/  
Parking Brake  
Lever* Check for smooth operation and adjust if needed (page 116 ).

*Headlight and  
Headlight Dimmer  
Switch* Check for proper function (page 22 ).

*Engine Stop Switch* Check for proper function (page 21 ).

*Steering* Check that the wheels turn properly as you steer the handlebar. Move the handlebar right and left and check that there is no excessive backlash.

Remember, be sure to take care of any problem you find, or have your Honda dealer correct it before you ride.

# Load Limits & Guidelines

---

Your Honda was designed as a rider-only ATV. It was not designed to carry a passenger or cargo. A passenger or cargo could interfere with your ability to move around to maintain your balance and control of the ATV.

In addition, exceeding the weight limits or carrying an unbalanced load can seriously affect your ATV's handling, braking and stability. Adding accessories or making modifications that change this ATV's design and performance can also make it unsafe. Also, the weight of any accessories will reduce the maximum load the ATV can carry.

More specific information on load limits, accessories, and modifications follows.

## Loading

How much weight you put on your ATV, and how you load it, are important to your safety. If you decide to carry cargo, you should be aware of the following information.

### **WARNING**

Overloading, improper loading, or carrying a passenger can cause a crash and you can be seriously hurt or killed.

Follow all load limits and other loading guidelines in this manual.

# Load Limits & Guidelines

---

## Load Limits

Following is the load limit for your ATV:

There is a limit to how much weight can be carried on your ATV.

The following load limit applies to standard equipment only. Modifying your ATV, using non-standard equipment, or riding on terrain that is not flat and smooth could further reduce this limit.

maximum weight capacity      110 kg (243 lbs)  
(includes the weight of the rider, all cargo, and accessories.)

The weight of added accessories will reduce the maximum cargo weight you can carry.

# Load Limits & Guidelines

---

## Loading Guidelines

As discussed on page 36 , we recommend that you do not carry any cargo on this ATV. However, if you decide to carry cargo, ride at reduced speeds and follow these common-sense guidelines.

Carrying cargo or pulling a trailer will affect how your ATV handles and greatly reduce its ability in accelerating, braking and making turns and other maneuvers.

Be sure to observe the weight limit and follow these guidelines:

- Check that the tyres are properly inflated.
- Never ride with a passenger. The ATV is not designed to carry a passenger.
- Do not tow another vehicle.
- Make sure all cargo is secured before riding.
- Never exceed the maximum weight limit.
- Allow extra room for starting, stopping and turning whenever you carry cargo or pull a trailer.
- Avoid riding on steep slopes when carrying cargo or pulling a trailer.
- Never cross a slope when towing a trailer.

# Accessories & Modifications

---

Modifying your ATV or using non-Honda accessories can make your ATV unsafe.

Before you consider making any modifications or adding an accessory, be sure to read the following information.

## **WARNING**

Improper accessories or modifications can cause a crash in which you can be seriously hurt or killed.

Follow all instructions in this owner's manual regarding accessories and modifications.

## Accessories

We strongly recommend that you use only Honda Genuine Accessories that have been specifically designed and tested for your ATV. Because Honda cannot test all other accessories, you must be personally responsible for proper selection, installation, and use of non-Honda accessories.

Check with your Honda dealer for assistance and always follow these guidelines:

- Make sure the accessory does not obscure any lights, reduce ground clearance, limit suspension travel or steering travel, or interfere with operating any controls.
- Make sure the accessory does not interfere with your ability to shift body position on the seat or operate hand and foot controls.

(cont'd)

# Accessories & Modifications

---

(TRX450ER only)

- Do not add any electrical equipment that will exceed the vehicle's electrical system capacity (page 204 ). A blown fuse can cause a loss of lights or engine power (page 191 ).

## Modifications

We strongly advise you not to remove any original equipment or modify your ATV in any way that would change its design or operation. Such changes could seriously impair your ATV's handling, stability, and braking, making it unsafe to ride.

Removing or modifying your lights, exhaust system, emission control system, or other equipment can also make your ATV illegal.

# Basic Operation & Riding

---

This section gives basic riding instructions, including how to start and stop your engine, how to use the throttle and brakes, and what to do when you're through riding.

To protect your new engine and enjoy optimum performance and service life, refer to Break-in Guidelines (page 205 ).

For information about carburetor adjustment for riding at high altitude, see page 206 .

Safe Riding Precautions .....	42
Off-road Use Only .....	42
Keep Hands and Feet on Controls .....	43
Control Speed .....	44
Use Care on Unfamiliar or Rough Terrain .....	45
Do Not Perform Stunts .....	46
Starting & Stopping the Engine .....	47
Preparation .....	48
Starting Procedure .....	50
Flooded Engine .....	54
How to Stop the Engine .....	55
Shifting Gears .....	56
Braking .....	58
Riding Your ATV .....	60
Making Turns .....	60
Skidding or Sliding .....	62
Riding Up Hills .....	63
Riding Down Hills .....	67
Crossing or Turning on Hills or Slopes .....	68
Riding Over Obstacles .....	70
Riding Through Water .....	71
Parking .....	72

# Safe Riding Precautions

---

Before riding your ATV for the first time, please review the *ATV Safety* section beginning on page 1, and the *Before Riding* section beginning on page 27.

Even if you have ridden other ATVs, take time to become familiar with how this ATV works and handles. Practice in a safe area until you build your skills and get accustomed to the ATV's size and weight.

## Off-road Use Only

Your ATV and its tyres are designed and manufactured for off-road use only, not for pavement. Riding on pavement can affect handling and control. You should not ride your ATV on pavement.

### **WARNING**

Operating this ATV on paved surfaces may seriously affect handling and control of the ATV, and may cause the vehicle to go out of control.

Never operate the ATV on any paved surfaces, including sidewalks, driveways, parking lots and streets.

When riding off-road, also remember to always obey local off-road riding laws and regulations. Obtain permission to ride on private property. Avoid posted areas and obey “no trespassing” signs.

# Safe Riding Precautions

---

You should never ride your ATV on public streets, roads or highways, even if they are not paved. Drivers of street vehicles may have difficulty seeing and avoiding you, which could lead to a collision. In many states it is illegal to operate ATVs on public streets, roads and highways.

## **⚠ WARNING**

Operating this ATV on public streets, roads or highways could cause you to collide with another vehicle.

Never operate this ATV on any public street, road or highway, even a dirt or gravel one.

## **Keep Hands and Feet on Controls**

Always keep both hands on the handlebars and both feet on the footpegs when riding your ATV. This is important to maintain your balance and to control the vehicle. Removing even one hand from the handlebars or one foot from the footpegs can reduce your ability to control the ATV or could cause you to lose your balance and fall off the ATV.

## **⚠ WARNING**

Removing hands from handlebars or feet from footpegs during operation can reduce your ability to control the ATV or could cause you to lose your balance and fall off of the ATV.

Always keep both hands on the handlebars and both feet on the footpegs of your ATV during operation.

# Safe Riding Precautions

---

## Control Speed

Riding at excessive speed increases the chance of an accident. In choosing a proper speed, you need to consider the capability of your vehicle, the terrain, visibility and other operating conditions, plus your own skills and experience.

### **WARNING**

Operating this ATV at excessive speeds increases your chances of losing control of the ATV, which can result in an accident.

Always go at a speed that is proper for your vehicle, the terrain, visibility and other operating conditions, and your experience.