



Owner's Manual



Important Safety Instructions Included.
Read through carefully before you ride.

XR250Y

Thank you for purchasing a Honda Motorcycle. For your safety and comfort, please familiarise yourself with this manual before riding.

At time of purchase

- * Please obtain this owners manual.
Ask your dealer about the following:
- Tips on handling and riding.
- Contents/period of the warranty.
- Service requirements
- Filling out the purchase receipt and the warranty card.
- Signing the Warranty registration form
– to verify that all the features of the machine have been explained to you.

Motorcycle rider's licence

This motorcycle has a total displacement of 249cm³(cc). You must hold a corresponding motorcycle rider's license in order to ride on public roads.

The vehicle is designed to carry a maximum of two people, including the rider. Note that you cannot carry a passenger for the first 12 months after obtaining your motorcycle license.

Safety Warnings

About this manual

* This manual contains the information for the correct handling, safe riding and basic maintenance. Please read through “**Safety Warning**”, “**Safe riding**” and “**Maintenance safety tips**” as they are particularly important.

* Even if you are familiar with motorcycles already, please read this manual as this model has some special features. Please also read the maintenance note.

* When re-selling the vehicle please hand the manual and the maintenance record to the next owner.

* Honda Motor Co., reserves the right to alter specifications and make other changes at any time without notice or obligation.

Safety warnings

* Safety warnings

The following safety warnings are used in this manual to alert you to the potential for danger to the rider, the passenger and the others. Always read the warnings thoroughly.



Warning: High potential of causing death or severe injury.



Caution: Potential of causing death or severe injury.



Note: Potential of minor injury.

* Other symbols:



Advice: To keep your motorcycle in peak condition.



Tips: To ensure best performance and pleasant riding.

Contents

MAINTENANCE SAFETY TIPS.....

Maintenance.....

Daily inspection.....

Regular service.....

Maintenance Schedule.....

Basic maintenance.....

Check Engine Oil.....

Drive Chain Inspection.....

Drive Chain Maintenance.....

Battery.....

Handling the Battery.....

First aid Information.....

Cleaning the Terminals.....

Removal and Installation.....

Brakes.....

Front brake.....

Brake fluid level.....

Brake pads wear.....

Rear brake.....

Brake fluid level.....

Brake pads wear.....

Clutch.....

Clutch free play adjustment.....

Fuses and relays.....

Inspection / replacement.....

Tyres.....

Pressure.....

Tread.....

Replacement tyres.....

Air Filter.....

Air filter element replacement.....

Engine Breather Drain.....

Engine Troubleshooting.....

Important Noise Warning.....

Specifications.....

Contents

FOR YOUR OWN SAFETY.....

PARTS LAYOUT.....

INSTRUMENTS

Instruments.....

Speedometer.....

Odometer.....

Trip meter.....

Warning Lights.....

Ignition Switch.....

Engine Stop switch.....

Headlight Dimmer switch.....

Engine Start Button.....

Turn Signal switch.....

Helmet Holder.....

Steering Lock.....

Tool Bag.....

BATTERY AND FUSES.....

SUSPENSION.....

Rear Cushion Adjustment.....

Compression Adjustment.....

Damping Adjustment.....

REFUELLING.....

Manual Fuel Shut-off Valve.....

STARTING THE ENGINE.....

Engine Start Procedure.....

Cold Starting Procedure.....

Hot Starting Procedure.....

RIDING THE MOTORCYCLE.....

Selecting the Correct Gear.....

Braking Correctly.....

Engine Braking.....

For Your Own Safety

- The topics described here are the basic instructions for handling the vehicle.

Please follow the instructions from your owner's manual.

Before Riding

- Please conduct the daily inspection. Keep the vehicle clean at all times and inspect the specified items.
- Please conduct the regular service.

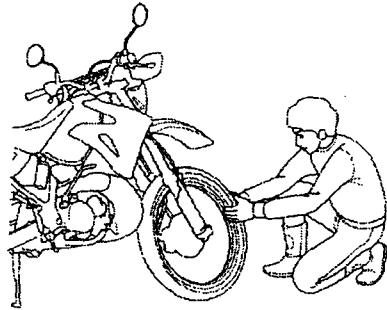

For Your Own Safety

Parking

- Park on stable and flat ground.
- Do not obstruct the traffic flow when parking your vehicle.
- Park the vehicle so as to keep the hot muffler away from other people.
- While running the engine or immediately after shutdown, do not touch the engine or muffler.

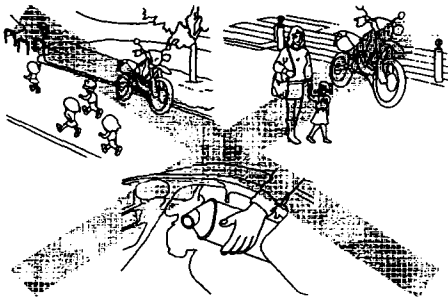

Parking with the sidestand

- Park on flat and stable ground with the handlebars turned fully to the left. The vehicle may have difficulty staying upright in the following circumstances:
 - The handlebars turned to the right.
 - Parked on sloped, soft, sandy or bumpy ground.

If there is no other choice, take maximum precautions to keep the vehicle stable.

For Your Own Safety

Luggage

- Controllability and stability of the vehicle changes by loading luggage. Be careful in terms of loading and securing the luggage.
- Do not place any items around the steering handle. It may obstruct the steering.
- Do not place any items in front of the headlamp. It may melt the lens or damage the item itself.

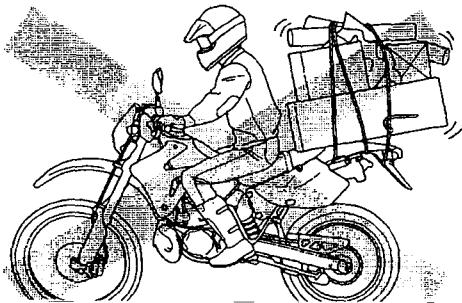

Modification

Any modification which affects the function and the structure of the vehicle may affect the controllability and exhaust noise, which may affect the durability of the motorcycle.

Any illegal modification may cause inconvenience to the surroundings. Any damage caused by these modifications is totally out of our warranty.

For Your Own Safety

Riding Tips

- Keep both hands on the handlebars and both feet on the footpegs at all times whilst in motion.
- The pillion passenger should place both feet on the rear footpegs and use both hands to stay in position. It is the rider's responsibility to check that the passenger is positioned correctly.
- Do not jerk the handlebars or attempt to ride with only one hand. This safety rule applies to any two-wheeled vehicle.

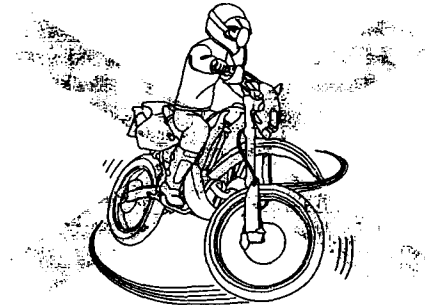
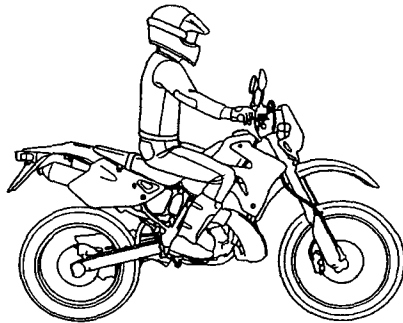

For Your Own Safety

Protective apparel

- *Both rider and passenger are required by law to wear a helmet. Secure the chin-strap properly. Helmets approved to AS1698 are the only legal helmets in Australia.*
- *Wear protective clothing and gear such as:*
 - *Face shield or goggles.*
 - *Motorcycle boots or any footwear that covers the ankles.*
 - *Leather gloves.*
 - *Long pants and a long sleeved jacket.*

Riding apparel should be bright or reflective.

Allow freedom of movement.

Avoid flared pants and loose sleeved jackets, which could get caught with the brake and gear shift pedals.



For Your Own safety

- Stop the engine before refueling and keep well clear of naked flames.
- Exhaust gas is toxic. Operate the engine in a well-ventilated place.

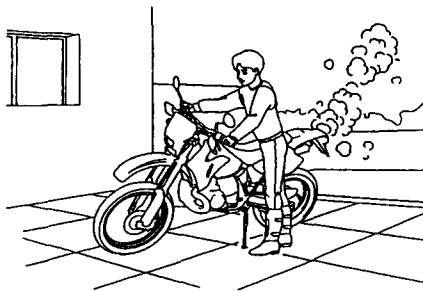
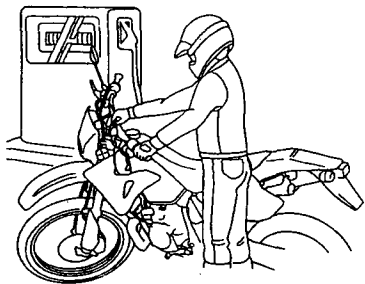

For your Safety

Stop the engine and remove the ignition key when carrying out any maintenance works.

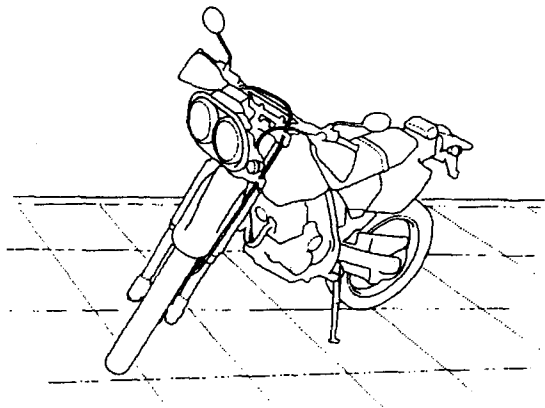
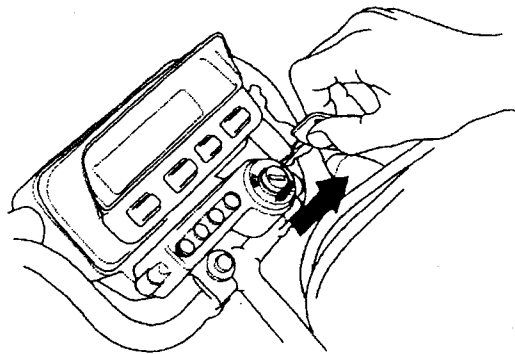

The motorcycle should be supported by the Side-Stand, on a flat and solid surface.

For your Safety

Whenever test riding is required, consider safety and traffic conditions and select appropriate area.

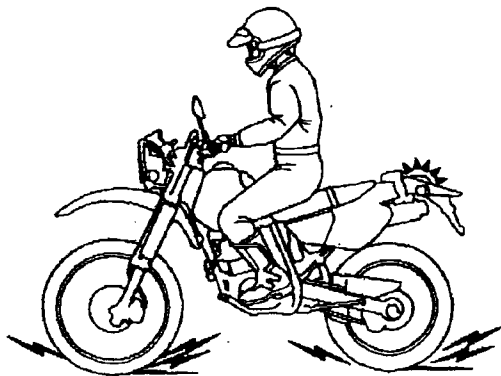

Always use appropriate tools for maintenance works.

Serial Numbers

Your motorcycle's vehicle identification number (VIN) is required to register your motorcycle and to order parts. Also this VIN is a primary clue when your vehicle is stolen. We recommend the VIN is recorded and stored together with your registration number in a separate place.

Vehicle Serial Number (VIN)

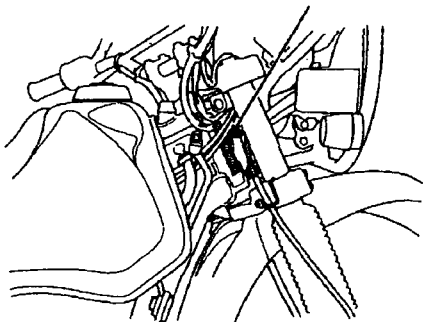

Engine Serial Number

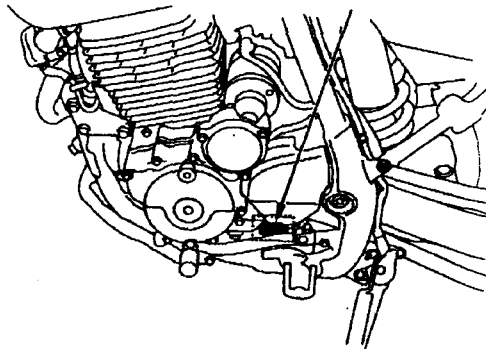

For your Safety

Exercise caution when servicing the engine, the exhaust pipe, or the muffler immediately after shutting down the engine. These areas may be extremely hot.

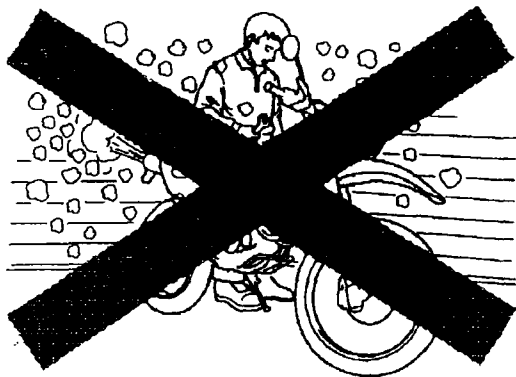
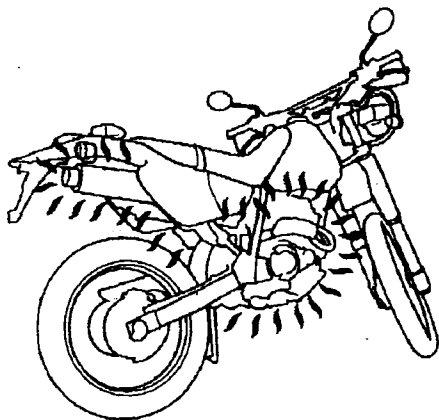

Exhaust fumes contain toxic gases such as carbon monoxide. Do not carry out any maintenance work that requires running the engine in confined, poorly ventilated area.

Ordering Coloured Parts

When ordering coloured parts, please quote the model name, the colour, and the colour code. This information can be found on a colour label, which is on the rear frame tube. The left side cover has to be removed to access the colour label.

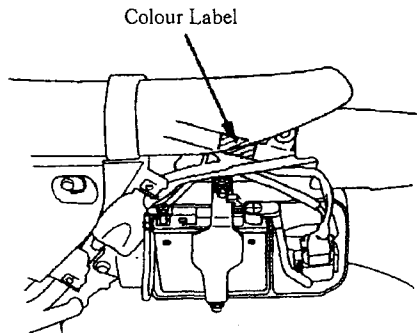

Genuine Honda Muffler

There is a Honda logo on the rear part of genuine Honda muffler.

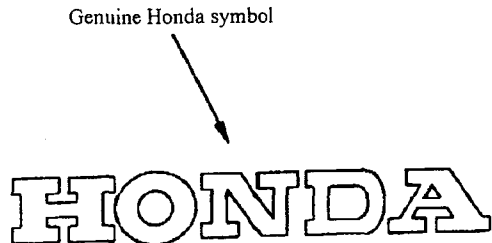

Caring for your motorcycle

- When washing your motorcycle, do not allow water to run into the muffler. Water inside the muffler may cause starting trouble and build up rust inside the muffler.
- Keep brake parts dry when washing. Wet brakes have reduced braking performance. After washing your motorcycle, drive slowly, in a safe area and check the brake function. If the braking performance is found to be poor, apply light braking while riding slowly in order to dry the brake discs/pads.

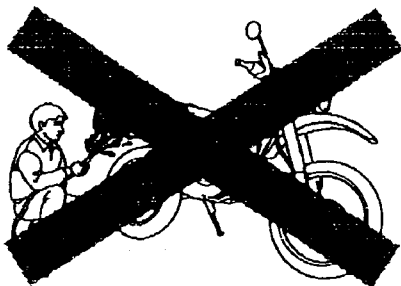

- When waxing the motorcycle, Do not rub the painted or plastic surfaces too hard. The painted/top coated surface may scratch or become thin and may have uneven colour.



Handling aluminium alloy parts

Aluminium alloy wheel rims have different characteristics from that of steel wheel rims. Please observe the following instructions in order to maintain the advantage of having an aluminium wheel rims. Always inspect rims for signs of Cracking or damage, especially when used off-road.

<Maintenance>

Aluminium alloy should be kept away from salt. After riding near the sea or any road surface where anti-freezing chemical is sprayed, clean the rim and rinse with water, then wipe off moisture with a dry cloth as soon as possible.

<Handling>

- Aluminium alloy is less resistant to scratches. Do not scratch or rub the parts with hard materials.
- A sandy soap or a hard steel wirebrush may damage aluminium parts.

Handling the exhaust pipe

The engine, the muffler and the exhaust pipe may be extremely hot immediately after stopping the engine. Take care to avoid burn injury when carrying out the maintenance.

The exhaust pipe is made from stainless steel. If you start the engine with oil and dirt on its surface, a burn-patch may form.

<Care>

- Use kitchen cleansing detergent to wipe off the dirt on the surface. Rinse with water and wipe with a dry cloth.
- In order to remove any burn-patch, polish with a fine polishing compound and then follow the same manner as removing the dirt.

Caring for your motorcycle

Please keep your vehicle in a safe place and use a cover when kept outside. Any cover used should be an open weave fabric that can breathe. The use of nylon or "sealed" materials will cause the machine to "sweat" and will result in surface corrosion.

Tip:

Always apply a cover well after the engine and the muffler have Cooled down, to avoid condensation build up and fire danger.

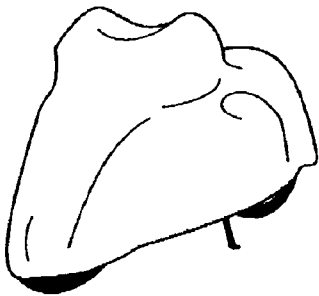

If you are not going to ride your motorcycle for a while, please:

- apply wax to prevent rust, and
- remove and store the battery in well ventilated area. Alternatively, you can disconnect the negative terminal of the battery and leave it mounted in the motorcycle.
- NOTE: Leaving the battery uncharged for any length of time, whether disconnected or not, will result in the battery discharging and may cause the battery to fail.
- When taking you machine out of storage, it may be necessary to drain old fuel from the carburettor bowl, to enable you to start the machine.

Environmental Consideration

Each rear cushion damper unit contains compressed nitrogen gas. Please consult your Honda dealer for servicing, replacement and disposal of the units.

Warning

Please do not throw the damper unit into fire, drill or disassemble the damper unit. It may explode and may result in fatal or serious injury.

Do not remove the valve cap. Nitrogen gas may discharge if the valve cap is removed.

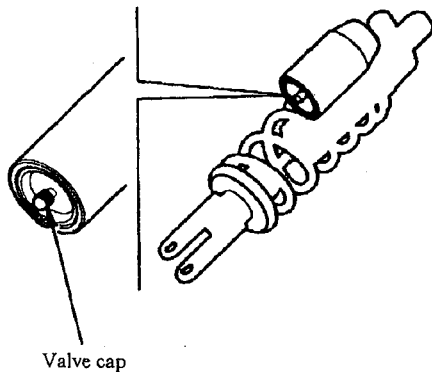

Environmental Consideration

As an environmental consideration, please consult your Authorised Honda dealer when disposing of any used parts or fluids from your motorcycle, ie; the battery, tyres, engine oil, and plastic parts. Incorrect disposal of any of these parts may have a detrimental effect on the environment. Your authorised Honda Dealer is best placed to dispose of any displaced parts or fluids in the correct manner.

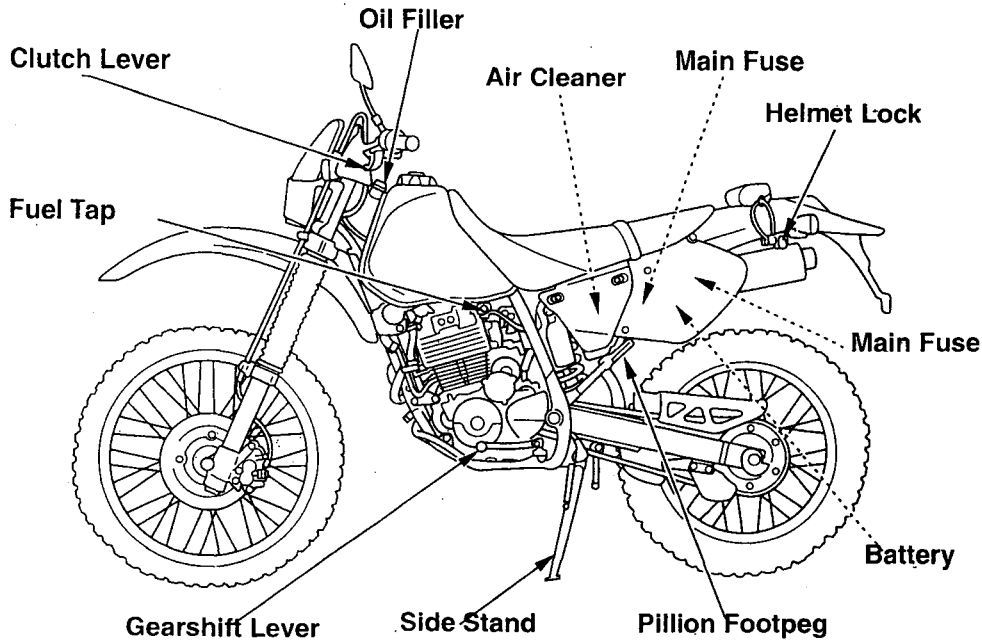

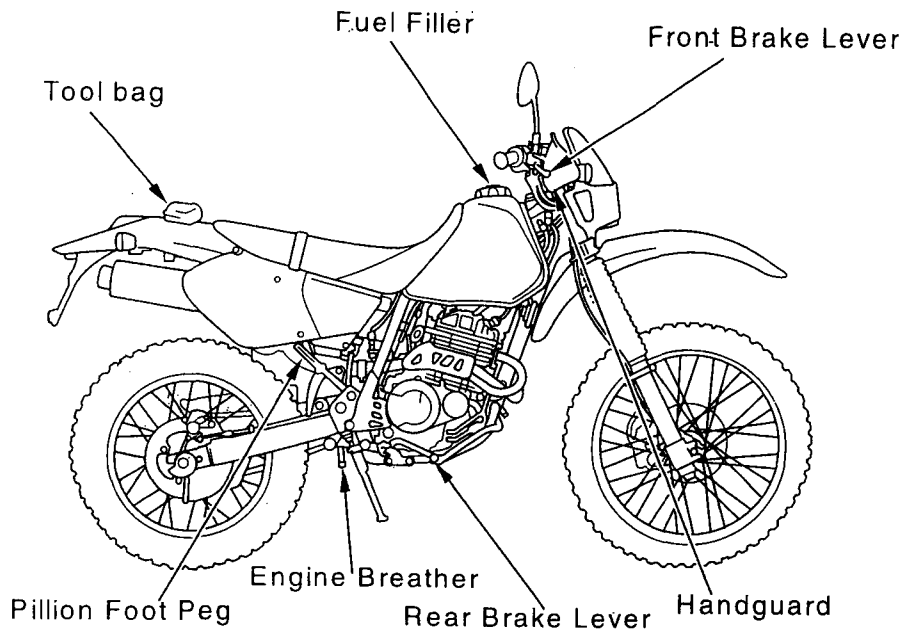

INSTRUMENTS

METER

Speedometer

The Speedometer indicates vehicle speed in kilometres per Hour.

Odometer

The Odometer indicates distance travelled in Kilometres. The last digit indicates in 100m intervals.

Trip Meter

The Trip Meter can be reset to "0" to show distance travelled for any given trip.

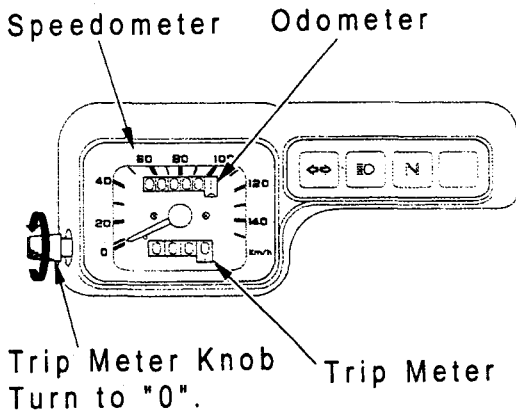

INSTRUMENTS

TELL TALE LAMPS

Direction Indicator

When the Direction Indicator switch is activated, the Tell Tale Lamp will illuminate and flash.

Hi-Beam Lamp

When Hi-Beam is selected, the blue Hi-Beam Tell Tale Lamp will illuminate.

Neutral Lamp

When the Ignition switch is in the "ON" position, the Green Neutral Lamp will illuminate.

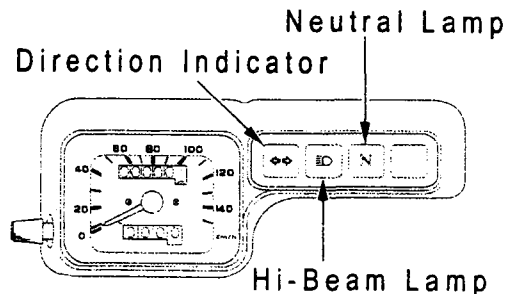

SWITCHES

Ignition Switch

The Ignition Switch turns the Ignition "ON" and "OFF".

Do not attempt to turn or remove the key while riding.

In the "OFF" or "LOCK" positions the engine will stop.

Always stop the motorcycle before attempting to turn the key.

Position	Function	Key
ON	Engine Start/Riding - Headlight is "ON" - Horn, Indicators and Stop Lamp will operate.	Can't be Removed.
OFF	Engine Stop. All electrics "OFF"	Can be
LOCK	Steering Locked All electrics "OFF"	Removed.

ADVICE

- The headlight will come on as soon as the Ignition is switched on. Do not leave the switch on or the battery will go flat.

NOTE

- Always lock and remove key when parking the m/cycle.

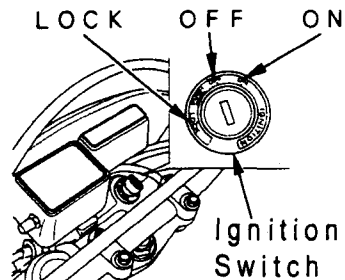

Instruments

Engine Stop switch:

The Engine Stop switch allows you to stop the engine immediately in an emergency situation.

The Engine Stop switch should be left in the "RUN" position during normal riding and only used in case of Emergency.

Switching between "RUN" and "OFF" whilst riding will lead to unstable engine operation, backfiring and probable engine damage.

Engine Stop Switch

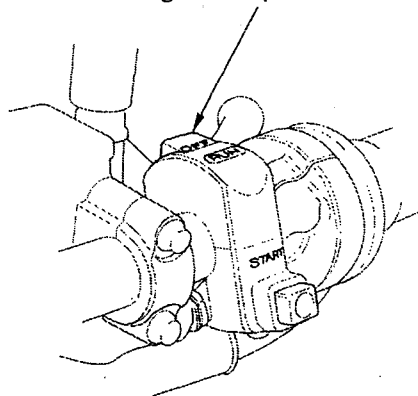

- ADVICE -

If using this switch in an emergency situation, switch the Ignition Switch to the "OFF" position, to avoid the battery going flat.

Instruments

Headlight Dimmer Switch:

This switch allows you to switch between Low Beam and High Beam. It is a legal requirement that you ride with your Low Beam on when other traffic is approaching.

To change between High and Low Beam, simply push the corresponding side of the switch. The switch is marked "HI" and "LO".

For High Beam - Press the "HI" side.
For Low Beam - Press the "LO" side.

NOTE:

The Blue High Beam Indicator, below the Digital Display will illuminate when the "HI" side of the switch is pressed.

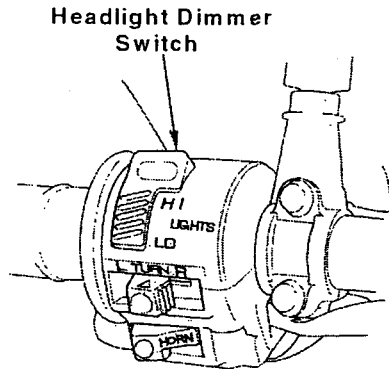

Instruments

Engine Start Button:

This button allows you to start the engine by engaging the Starter Motor - If the engine does not start, check that the Engine Stop switch is in the 'RUN' position.



- ADVICE -

The Starter Motor draws considerable power. Avoid extended cranking to prevent flattening the battery.



- TIP -

The Headdlight will turn 'OFF' when the Starter Motor is engaged.

Horn Button:

The Horn Button allows you to sound the Horn to warn other road users or pedestrians. The Horn can only be operated when the Ignition Switch is in the 'ON' position.

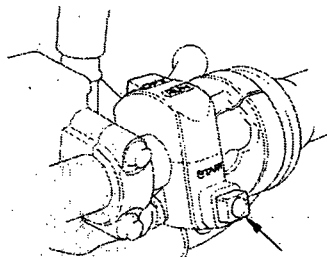

Engine Start Button

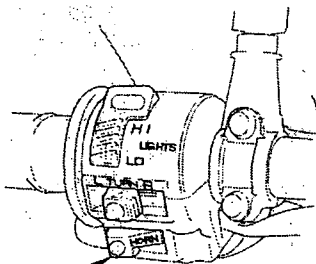

Horn Button

Instruments

Turn Signal Switch:

The Turn Signal switch is used to operate the Turn Signal Lamps when turning Left or Right, or when changing lanes.

The Ignition Switch must be in the 'ON' position for the Turn Signal Lamps to operate.

To operate, push the switch button to the side that corresponds with the Turning direction. ie; R.....Right and L.....Left.

- TIP -

- The Turn Signals do not automatically cancel. Always cancel the Turn Signal after turning to avoid confusing other road users.
- Always use correct wattage globes - Use of incorrect wattage globes may result in erratic or incorrect flash rate.

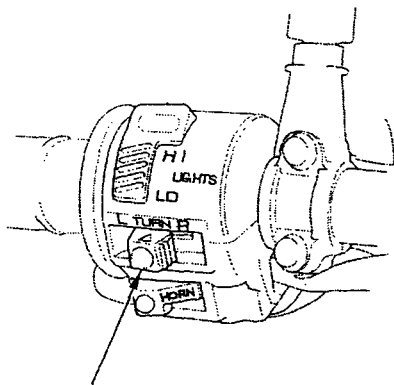

Turn Signal Switch

Helmet Holder

Only use the Helmet Holder when the motorcycle is parked. Otherwise damage to the m/cycle or the Helmet may occur.

How to use:

1. Insert the Ignition key and turn it to the left to release lock.
2. Put Buckle of Helmet strap over the pin and push pin until it locks into place.

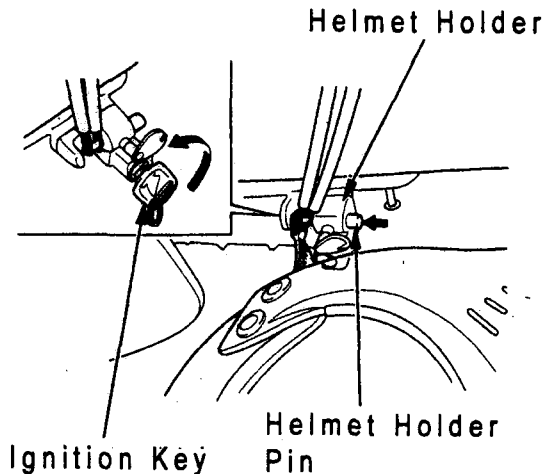

FEATURES

Steering Lock

For security reasons, always lock the steering when you park the motorcycle. Use of a chain lock is also recommended.

Lock Steering:

1. Turn Handlebars to the Left.
2. Push Ignition Key in and turn to "LOCK" position.

Jiggle Handlebars to make sure Steering is locked. Remove Key.

Unlock Steering:

1. Insert Ignition Key
2. Push key in and turn to the "OFF" position.

If the key cannot be turned easily, jiggle the handlebars to release any tension on lock.

NOTE:

- Always park in appropriate place, safely away from traffic.
- Always make sure steering is locked, by jiggling handlebars, before leaving m/cycle.

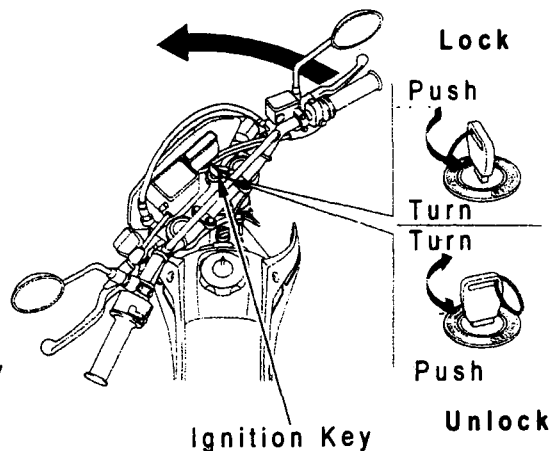

Tool Bag

There is a tool bag behind the seat.

- Please store your owner's manual and maintenance notes in this bag.
- Simple Repair tools can also be stored in this bag.

Directions for use:

Release the helmet holder and release the locking wire for the bag. Then the fastener may be opened.

- Always secure the tool bag with the wire and the helmet holder.

Tips:

- Do not apply excessive water to the tool bag to minimise the risk of water leaking into the bag.
- Do not put valuable or fragile items in the bag.

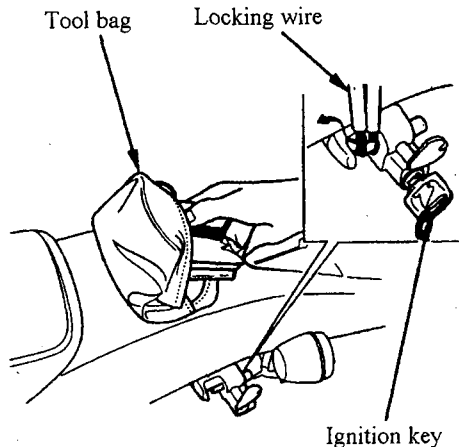

Battery and Fuses

Left Side Cover

The battery and fuses can be accessed by removing the left side cover.

Removal:

1. Remove the two bolts at the front part of the left side cover. Then remove the remaining two bolts at the rear of the cover.
2. Release catches at the back to remove the cover.

Installation:

1. Insert the rear catches of the cover into location.
2. Secure two front bolts, then the rear bolts.

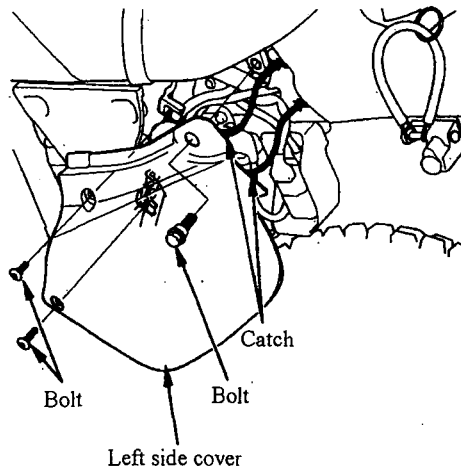

Suspension

Rear cushion adjustment:

The rear cushion can be adjusted to suit the rider's weight and riding conditions.

Adjusting the compression damping:

Adjustment can be done by winding the adjuster with a flatblade screwdriver. Damping is increased by turning the adjuster clockwise and vice versa.

The default setting is turning the adjuster clockwise to its full stop then winding back for the following number of "clicks"

(The punched mark should be aligned with the adjustment mark):

7 to 10 clicks

- **Do not force the adjuster to turn.**

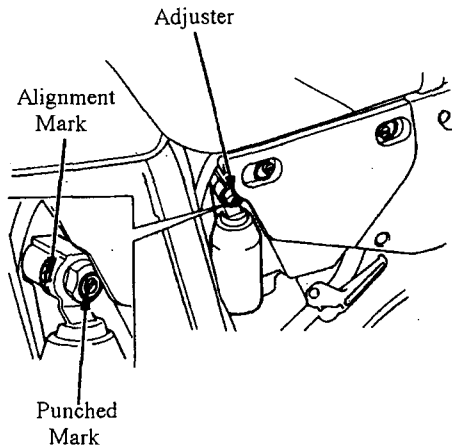

Suspension

Damping adjustment:

An adjuster is located at the lower part of the rear cushion main body and is accessible from the left side of the motorcycle.

A flat blade screwdriver is required to make the adjustment. Damping can be increased by turning the adjusting screw clockwise and vice versa.

The default setting is turning the adjuster clockwise to its full stop then winding back for the following number of "clicks"

(The punched mark should be aligned with the adjustment mark):

10 to 13 clicks

- **Do not force the adjuster to turn.**

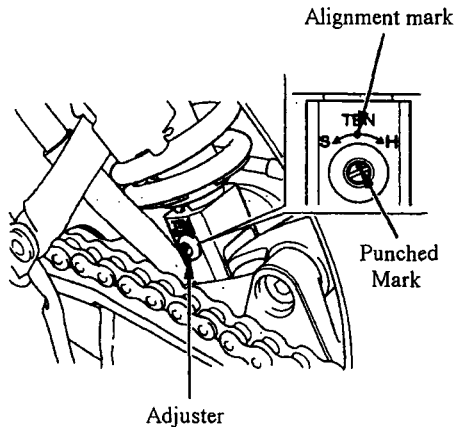

Refuelling

Always Use Unleaded fuel.

When refueling, stop the engine and keep well clear of naked flames or other possible sources of ignition.

Warning:

Petroleum is highly flammable. When handling petroleum:

- Stop the engine. Keep well clear from naked flames, sparks, and any kind of heat source.
- Do not refuel indoors.
- Wipe off spilt fuel immediately.

Refuelling Instructions:

1. Open the key cover. Insert the Ignition key and turn it clockwise. Turn the fuel tank cap counter clockwise to remove.

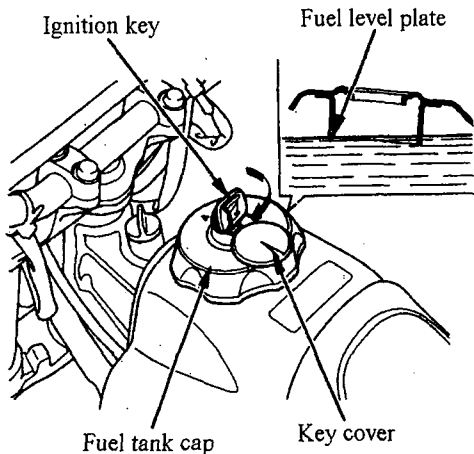

Refuelling

2. Fill petrol to the bottom end of the fuel level plate.

NOTE: Fuel above the bottom end of the plate may spill out from the fuel tank cap breather.

3. Turn the fuel tank cap clockwise fully and turn the key counterclockwise to lock. Then close the key cover.

The key cannot be released unless the fuel tank cap is secured and locked.

Manual Fuel Shut-Off Valve:

The valve lever position indicates the fuel selection:

ON : Fuel flows to the carburettor. The engine should be started with the valve at this position.

OFF : Fuel is shut-off. The lever should be set to this position whenever the motorcycle is left unattended.

RES : If fuel has run out while riding, select this position and refuel as soon as possible. Make sure the lever is returned to ON position after refueling to prevent reserve fuel starvation.

Reserve fuel capacity:

Approx. 3.5 ltrs

ON OFF RES



Starting the Engine

Engine start procedure

Engine exhaust fumes contains toxic gases such as carbon monoxide. Engine should only be run in well-ventilated place.

Follow the engine starting procedure described in this manual.

Advice:

- If the engine fails to start after cranking for approximately five seconds, let the starter rest for about ten seconds. This helps reduce the battery voltage drop.
- Do not open throttle during warm up. Revving when cold can result in wasting fuel and may harm the engine.

Notes:

- This motorcycle employs a safety starter mechanism. It prevents the engine from being started with a gear engaged. However, it still enables the engine to be started by holding a clutch lever.
- This motorcycle also employs an ignition cut-off side stand. It automatically shuts off the engine if any gear is selected with the side stand extended. Always retract the side stand prior to starting the engine or riding.

Starting the Engine

Engine start procedure

When engine is cold:

1. Release the Steering lock.
2. Set the engine stop switch to RUN position.
3. Turn the Fuel Tap valve to the ON position.
4. Turn the ignition switch ON.
5. Ensure that the Neutral Indication lamp is ON.
6. Pull out the choke lever fully.
7. Engage the Starter – Do Not Touch the Throttle.
8. Once the engine starts, warm up until smooth running is achieved. Fully push the choke lever in.
9. Make sure that the side stand is retracted prior to starting the engine or riding away.

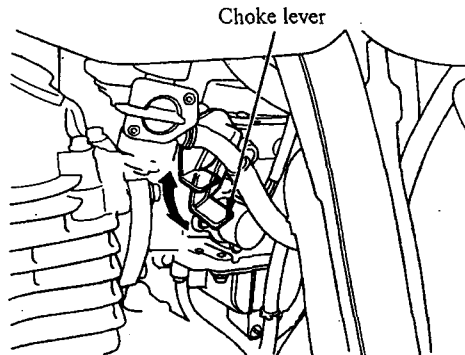

- If the engine does not start, refer to pg. 95 for troubleshooting.

Starting the Engine

When engine is hot:

1. Release the Steering Lock.
2. Set the engine stop switch to RUN position.
3. Turn the fuel selector valve to ON position.
4. Turn the Ignition to the ON position.
5. Ensure the Motorcycle Transmission is in the Neutral Position (Neutral Lamp should be on.)
6. Do not operate the Throttle while engaging the Starter Motor. If the engine fails to start after few cranks, proceed to 7.
7. Open throttle approximately $\frac{1}{8}$ turn and engage the starter.
8. Ensure that the side stand is retracted prior to starting the engine or riding away.

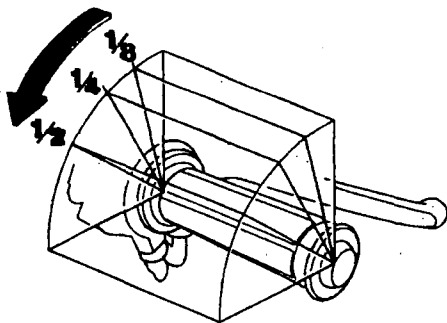

- If the engine does not start, refer to troubleshooting in back of this manual.

Riding the Motorcycle

Selecting a gear

The transmission is a six-speed Manual Transmission:

- When changing gear, release the throttle and pull in the clutch lever.
- Move the gear shift pedal with your toe until you feel the detent on each gear position. Do not force the pedal or shift without using the Clutch or Transmission damage may occur.

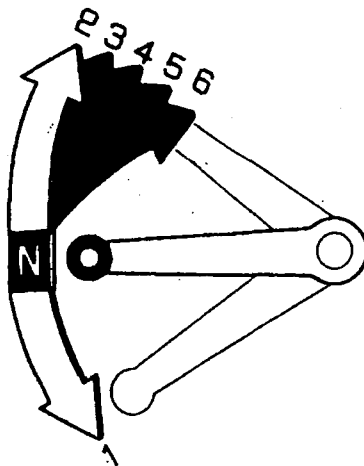

Riding the Motorcycle

Riding your motorcycle

- Always ensure the side stand is retracted before starting the motorcycle or riding away.
- Selection of the correct gear is essential. Refer to the table on this page for the gear selection.
- Avoid unnecessary acceleration/deceleration to prevent wasting the fuel and to maximize the vehicle life.

Advice:

Always consult your Honda dealer as soon as you notice abnormal sound and condition.

Tips:

- Make Take-off as smooth as possible.
- Observe local maximum permitted speed.

Gear	Speed range
Low	0 - 35kph
Second	10 - 50kph
Third	15 - 70kph
Fourth	20 - 95kph
Fifth	25 - 115kph
Top	25kph and above

Break-in

Appropriate Running-In Procedure is essential to maintain optimum performance of your motorcycle.

Avoid rapid acceleration/deceleration during initial 500km.

Riding the Motorcycle

Downshifting

For overtaking and other purposes, better acceleration is obtained by shifting down. However, gear shift-down at excessively high speed may increase engine rpm beyond its permissible limit and may harm the engine and the transmission. Always observe the speed range table for gear shift-down.

Gear	Maximum shift-down speed
Top to Fifth	115kph
Fifth to Fourth	95kph
Fourth to Third	70kph
Third to Second	50kph
Second to Low	30kph

Riding the Motorcycle

Braking

- Apply front and rear wheel brakes simultaneously in order to maximize braking effect.
 - Avoid unnecessarily heavy braking. It may lock the wheels and the vehicle may lose its stability.
 - Wheels are likely to lock and brake-stop distance increases when the road surface is wet. Keep riding speed lower in such a condition.
 - Continuous braking should be avoided as it may raise the brake temperature and reduce braking effectiveness.
- Braking effectiveness is reduced when riding in the rain and when riding over any wet surface. Check the braking function by gently applying brakes at low speed in open area. If braking effectiveness is bad and brakes are wet, apply brakes and ride at low speed for a while to dry the brakes.

Riding the Motorcycle

Engine braking

Release the throttle grip to use the engine brake. Should further engine braking be required, shift the Transmission to a lower gear.

Abrupt shift down should be avoided as it may result in "fishtailing". Refer to the table on previous pages.

Combined use of the engine and wheel braking is recommended in long or steep downhill slopes.

Maintenance

For your safety and comfort, always carry out a Daily Maintenance check, or check the Motorcycle before riding. For Routine Maintenance, always consult your Authorised Honda Dealer.

Warning:

Inappropriate service work or repairs can result in accidents involving fatal or serious injuries.

- Observe the Owner's Manual and the Maintenance notes contained therein.
- Always rectify any defect prior to riding.

Please refer to this manual for the following information:

First one-month check _____.

Replacement Parts. _____.

Daily Checks _____.

Service components layout _____.

Scheduled service _____.

Service item checklist _____.

Basic maintenance _____.

Engine oil _____.

Drive chain _____.

Brakes _____.

Clutch _____.

Battery _____.

Fuses _____.

Tyres _____.

Air filter _____.

Breather drain _____.

Maintenance

Initial one-month check

Your motorcycle must be returned to your Authorised Honda Dealer at One Month or 1,000km for its First Service, as it is vital in maximizing your motorcycle's life. The First Service is carried out at your cost and will help to ensure the longevity and safe operation of your motorcycle.

Spare parts

Whenever spare parts are required, please use genuine Honda parts. Genuine Honda parts pass our strict quality inspection and are optimised for Honda products. Genuine Honda Parts are covered by a factory Warranty.

Please consult your Honda dealer for spare parts.

Genuine Honda parts can be identified by the logo shown below.



Daily inspection

Daily inspection

It is vital to the Safe operation and longevity of your motorcycle that you carry out a Daily or pre-ride inspection prior to any riding.

Please refer to the items listed on this page for this inspection. Further descriptions are available for underlined items. Please refer to the following pages for locations of each component mentioned here, and shown on the next few pages.

For further information, please refer to the Maintenance Section of this manual.

Daily inspection items:

- Brakes
 - Lever free play (hydraulics)
 - Pedal free play (hydraulics)
 - Brake fluid level
- Wheels & Tyres
 - Tyre pressure
 - Cracks & damage
 - Tread *
 - Spokes for Tension and condition
- Engine
 - Engine oil level *
 - Starting & noise *
 - Low rpm & acceleration *
- Lamps & indicators
- Any defects found on the previous ride

* These items should be checked in accordance with appropriate service schedule.

Daily inspection

Component layout

Please refer to the diagrams shown on these pages, and to the diagrams in the front of this manual.

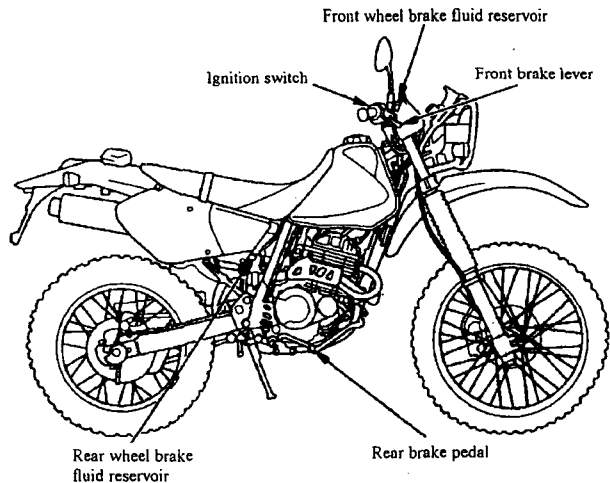

Daily Inspection

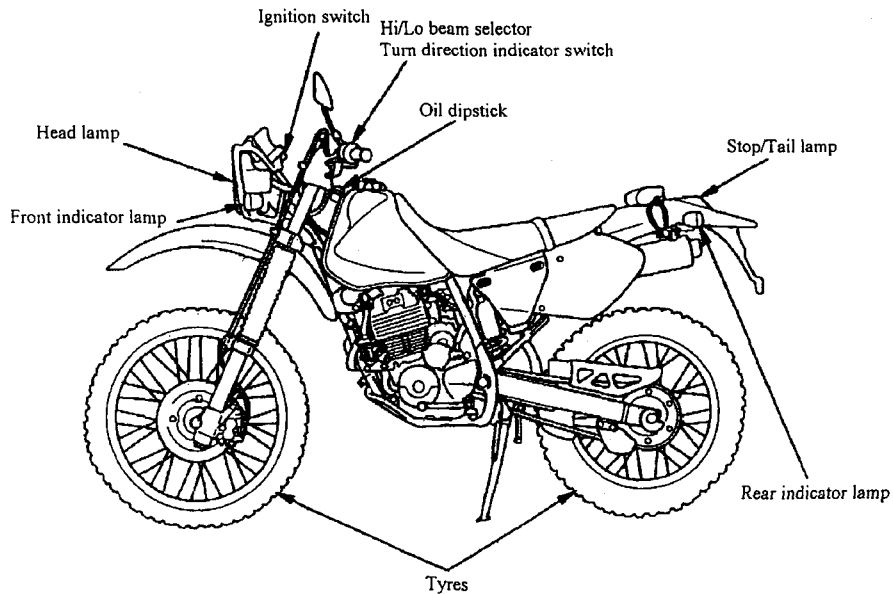

Scheduled servicing

Scheduled servicing

Servicing is scheduled at six monthly intervals or 6000km intervals. There is also an initial Service at 1000km or one month, whichever comes first.

Carrying out scheduled services & inspections are vital for your comfort and safe riding. It is your responsibility to take necessary action to arrange the service.

- If there is any difficulty in carrying out the service, please consult your Honda dealer.
- Do not attempt to carry out servicing yourself, unless you are suitable qualified and have all necessary tools and equipment..

Please refer to the Maintenance Schedule and information contained in this manual.

The details of regular services should be recorded in your maintenance notes.

The next few pages list items that require inspection, adjustment or servicing at regular maintenance intervals.

Routine Maintenance Items -

- Ignition - Spark plug condition
- Engine - Exhaust fumes
- Lubrication - Engine oil leaks
- Engine oil quality & quantity
- Cooling system - Coolant level
- Clutch - Clutch lever free play
- Clutch operation
- Chain & Sprockets - Chain slack
- Brake pedal & brake lever - Free play
- Hoses & pipes - Leaks, damage, and attachment
- Switches - Correct Operation

Honda Recommended Service Schedule - Please refer to the Maintenance Schedule in this manual.

- Brake system - Pad wear, Fluid Leaks
- Blow bypass system - Cleaning breather drain

Basic maintenance

Some basic and frequently carried out service items will be described over the next few pages.

Please use appropriate tools and keep within your capacity.

For your own safety, always consult your Honda dealer if you do not have appropriate tools or knowledge to carry out the basic servicing.

MAINTENANCE SCHEDULE

The following Maintenance Schedule specifies all maintenance required to keep your motorcycle in peak operating condition. Maintenance work should be performed in accordance with standards and specifications of Honda by properly trained and equipped technicians. Your authorized Honda dealer meets all of these requirements.

Perform the Pre-ride Inspection (page) at each scheduled maintenance period.

I: INSPECT AND CLEAN, ADJUST, LUBRICATE OR REPLACE IF NECESSARY

C: CLEAN R: REPLACE A: ADJUST L: LUBRICATE

ITEM	FREQUENCY	WHICHEVER COMES FIRST ↓ NOTE	ODOMETER READING [NOTE (1)]							
			x 1,000 km	1	6	12	18	24	30	36
			MONTHS		6	12	18	24	30	36
* FUEL LINE					I		I		I	—
* FUEL STRAINER SCREEN				C	C	C	C	C	C	—
* THROTTLE OPERATION					I		I		I	—
* CARBURETOR CHOKE					I		I		I	—
AIR CLEANER		NOTE (2)				R			R	
CRANKCASE BREATHER		NOTE (3)			C	C	C	C	C	
SPARK PLUG				I	R	I	R	I	R	
* VALVE CLEARANCE				I	I	I	I	I	I	
ENGINE OIL				R	R	R	R	R	R	
** ENGINE OIL STRAINER SCREEN						C		C		C
* ENGINE IDLE SPEED				I	I	I	I	I	I	
BRAKE FLUID		NOTE (4)			I	I	R	I	I	R

ITEM	FREQUENCY	WHICHEVER → COMES FIRST ↓ NOTE	ODOMETER READING [NOTE(1)]							
			x1,000km	1	6	12	18	24	30	36
			MONTHS		6	12	18	24	30	36
			I L EVERY 1000km							
				I	I	I	I	I	I	
			I		I		I		I	
*					I		I		I	
*					I		I		I	
			I	I	I	I	I	I	I	
					I		I		I	
*					I		I		I	
*			I		I		I		I	
**					I		I		I	
**			I		I		I		I	

- * SHOULD BE SERVICED BY AN AUTHORIZED HONDA DEALER, UNLESS THE OWNER HAS PROPER TOOLS AND SERVICE DATA AND IS MECHANICALLY QUALIFIED. REFER TO THE OFFICIAL HONDA SHOP MANUAL.
- * * IN THE INTEREST OF SAFETY, WE RECOMMEND THESE ITEMS BE SERVICED ONLY BY AN AUTHORIZED HONDA DEALER.

Honda recommends that your authorized Honda dealer should road test your motorcycle after each periodic maintenance is carried out.

- NOTES: (1) At higher odometer readings, repeat at the frequency interval established here.
 (2) Service more frequently when riding in unusually wet or dusty areas.
 (3) Service more frequently when riding in rain or at full throttle.
 (4) Replace every 2 years, or at indicated odometer interval, whichever comes first. Replacement requires mechanical skill.

Engine oil

The engine, the muffler and the exhaust pipe may be extremely hot immediately after shutting down the engine. Please be careful to avoid burn injuries.

Prior to starting the engine and checking the oil level, please carry out the following checks:

1. Place the motorcycle on even ground.
2. Remove the oil level dipstick.
3. Wipe oil off the dipstick.
4. Ensure that the motorcycle is upright and insert the dipstick. Do not screw in.
5. If oil can be seen on the stick, proceed to check the oil quantity.

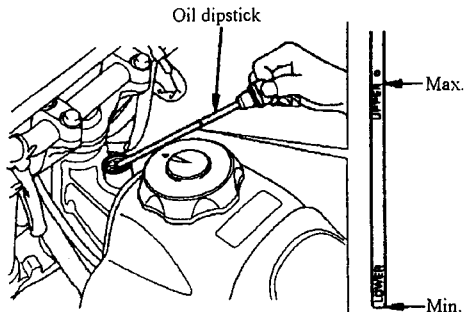
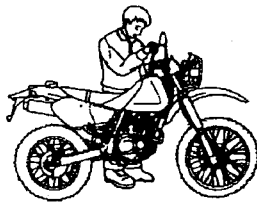

If oil cannot be seen on the dipstick:

Remove oil check bolt and sealing washer on the right hand side of the crankcase.

If oil leaks from the check bolt hole:

Refit the check bolt and the sealing washer. Refer to the procedure for checking the Oil quantity in the engine.

If oil does not leak from check bolt hole:

Refit the check bolt and the sealing washer. Remove the dipstick and pour some oil into frame. Re-insert the dipstick and refer to the procedure for checking the oil quantity in the engine.

Wipe any spilt oil prior to starting the engine.

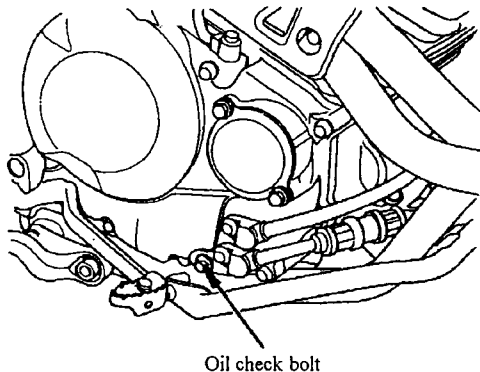

Oil Quantity check

1. Park the motorcycle on flat and level surface. Start and warm-up the engine, particularly in cold climates. Warm up can be done with the side stand extended and the motorcycle leaning to one side.

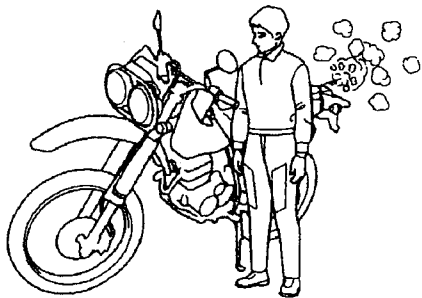

2. After warming up the engine, let the engine run at idling rpm for about one minute while the motorcycle is held upright.



After engine warm-up, do not run the engine at idling rpm or let the motorcycle lean to one side.

3. Stop the engine and remove the oil dipstick straight away.

4. Wipe the oil from the dipstick.

5. Hold the motorcycle upright and insert the dipstick. (Do not screw in.)

6. The oil level should be in between the Max and the Min lines. Top up to the Max line if the oil level is low.

7. Refer to the next page for further details of adding oil. Secure the dipstick.

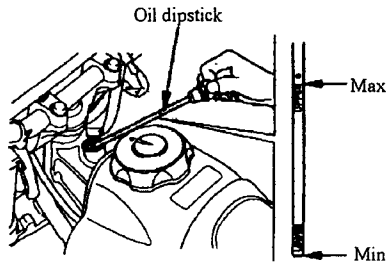
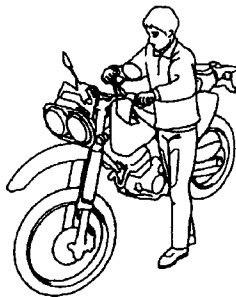

Adding engine oil

Recommended oil: Genuine Honda Four-stroke motorcycle oil or equivalent.

	API Class	SAE grade
Ultra U	SE class	10W-30
Ultra GP	SF class	10W-40 or 20W-50

If you are using equivalent products, please check the label to ensure that it conforms with the above table (for SAE, please refer to the temperature-viscosity chart on the next page).

Although it is rare, some products are not suitable for this motorcycle, even though both their API and SAE classification match the above table.

Tips:

- The clutch is submerged in the engine oil. Engine oil with additives or modifiers may cause the clutch to slip and add difficulties in starting the engine. It may affect the engine's performance and life. Therefore:
 - Do not use engine oil with additives or Friction Modifiers, and
 - Do not add any of those additives to the oil.
- Do not mix different brands and/or grades of oil, and do not use oil that does not match the chart, regardless of the quality. Use of such oil may reduce the engine performance and may cause damage to the engine.

Engine oil temperature-viscosity chart

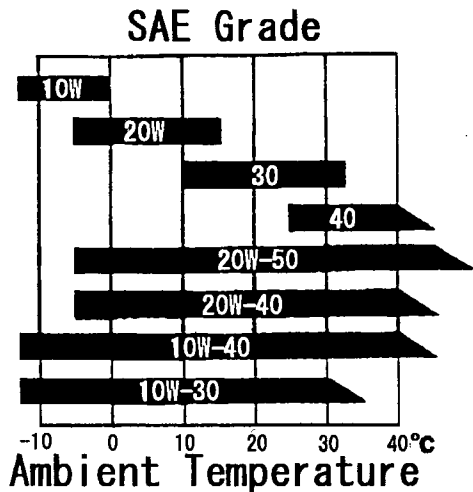

Oil change intervals:

Initial: 1,000km

Subsequent: every 6,000km

Please consult your Honda dealer for the oil change.

Drive chain

Extend the side stand and let the motorcycle lean on it. Move the drive chain up and down at the midpoint between the two sprockets. The chain slack should be within the following range:

Drive chain slack: 30 - 40mm

Adjust the tension if the slack is beyond the above range.

Never ride the motorcycle if the chain slack is in excess of 60mm.

Hold the motorcycle upright and move it back and forward to check the smooth chain movement. If the chain does not travel smoothly or if you hear any noise, the chain should be inspected.

Please consult your Honda dealer for the drive chain adjustment.

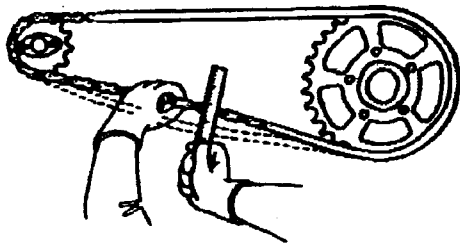

Drive chain slack

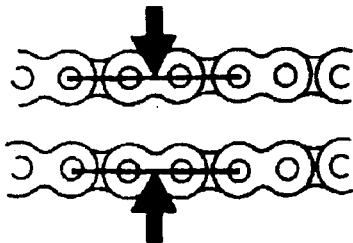

Lubricating and cleaning the drive chain

Remove dirt and mud on the drive chain and sprockets by using a brush. Move the motorcycle back and forward to clean the entire chain and both sprockets. Do not steam-clean the chain as it may cause damage to the Rubber o-rings.

After cleaning all dirt from the chain, apply lubrication along its surface. Apply from both sides of the chain rollers. Excessive lubrication may splash onto your clothing or the motorcycle itself.

Recommended lubrication:

Genuine Honda chain oil or gear oil #80 - #90

Or equivalent.

Tip:

Some non-Honda chain oil, including chain spray, may contain additives, which may reduce the chain life.

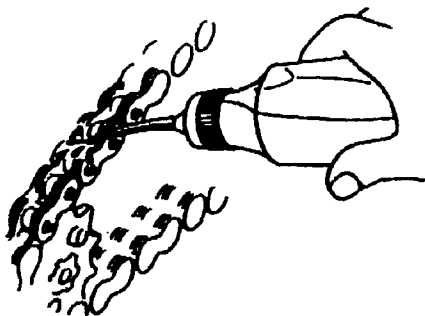

Battery

This motorcycle is equipped with a maintenance-free battery. There is no need to check/refill the battery fluid. The only maintenance required is to keep its terminals clean.

Handling the battery

- Please keep clear of any naked flames and sparks when handling the battery.
- Battery fluid is corrosive and toxic. Exercise caution to avoid physical contact with eyes and skin.

Tip:

The battery is sealed. Do not remove the fluid filler cap. There is no need to open the cap when charging the battery.

Warning:

Battery fluid contains sulfuric acid. Direct contact with eyes and skin may result in severe burn.

- Always wear safety goggles and protective clothing when working near the battery.
- Keep the battery out of reach of children.

First-Aid Information:

- **Eye-contact:**
Rinse for at least 15 minutes from water in a glass. Do not rinse with tap water as running water flow may damage eyes.
- **Skin-contact:**
Remove the contaminated clothing and wash the skin with running water.
- **Swallowed:**
Drink water or milk.
Do not induce vomiting.

After any first-aid treatment, consult a Doctor as soon as practical.

Cleaning the battery terminals

Remove the battery (refer to the next page).

- If corrosion is evident by white powder on the terminals, wipe off with warm water.
- If the corrosion is severe, polish with a wire brush or sandpaper.

Re-install the battery after cleaning the terminal.
Apply small amount of grease over the terminals.

When replacing the battery, always select the same model of the maintenance-free type.

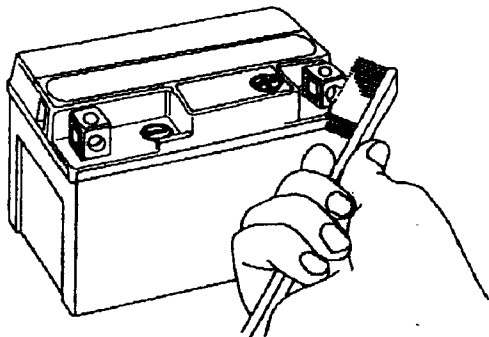

Battery removal & installation

Removal:

1. Remove left side cover
2. Remove negative terminal bolt and disconnect the negative lead.
3. Remove positive terminal bolt and disconnect the positive lead.
4. Remove lower battery holder bolts.
5. Remove upper battery holder bolt and collar to remove the battery holder.
6. Remove the battery.

Installation:

Reverse the above procedure to re-install the battery.

Always connect the positive terminal lead first. Firmly secure the terminal bolts/nuts.

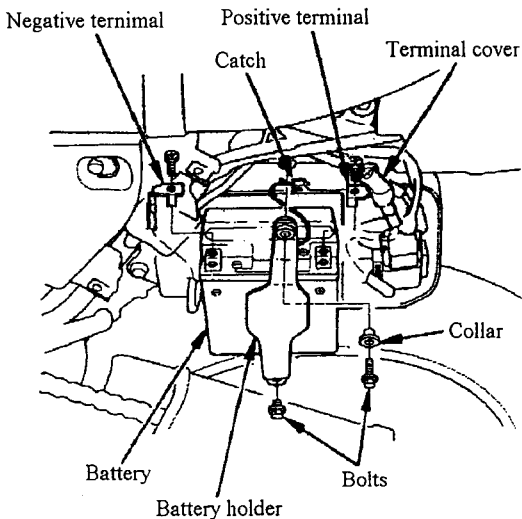

Brakes

<Brake fluid check>

[Front]

Lean the motorcycle on the side stand on a flat and level surface. Turn the handlebar in order to level the top surface of the reservoir cap. The fluid level should be at or above the lower limit line.

[Rear]

Hold the motorcycle upright on a flat and level surface to align the brake fluid level with the level lines. The fluid level should be in between the maximum and the minimum lines.

Inspect the brake pads for wear if the fluid level is lower than its lower limit line. For inspection (see the next page).

If the brake pads are fine, check for brake fluid leakage. Consult your Honda dealer.

[Front]

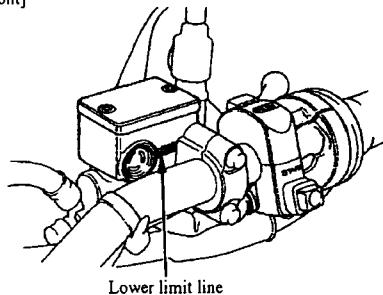

[Rear]

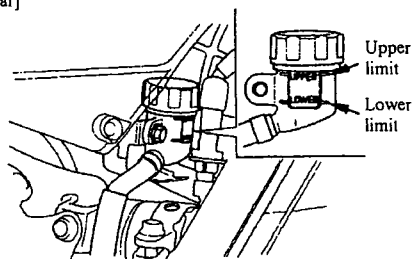

Brake pad Inspection:

[Front]

Look at the brake caliper from the bottom and check the brake pad wear indicators. If the indicator grooves have reached the side of the brake disc, the pads should be replaced.

[Rear]

Look at the brake caliper from behind and check the brake pad wear indicators. If the indicator grooves have reached the side of the brake disc, the pads should be replaced.

When replacing brake pads, always replace both sides at the same time.

Please consult your Honda dealer for brake pads change.

[Front]

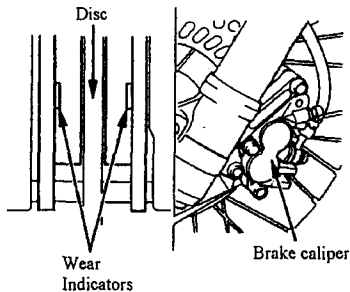

[Rear]

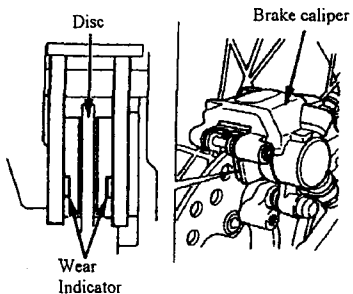

Clutch

Clutch lever free play

Pull the clutch lever until you feel resistance. The clutch lever free play at its end should be within the following range:

Clutch lever free play: 10 - 20mm

Please adjust the lever free play if necessary (see the next page for details).

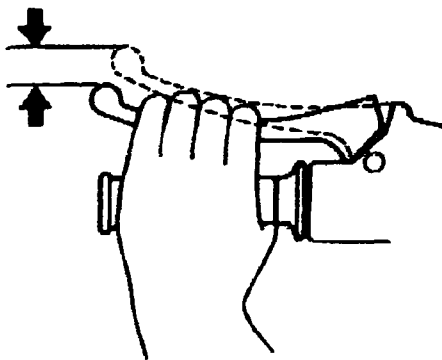

Clutch free play adjustment

The free play can be adjusted either at the clutch lever end or the clutch adjuster at the end of the clutch cable. However, it is recommended that you adjust the lower adjustment first.

- Loosen the lock nut and turn the adjuster to adjust.
- Secure the lock nut after the adjustment.

After securing the lock nut, re-check the clutch free play at the lever and, if necessary, make fine adjustment at the lever.

Also, start the engine and select each gear to check smooth engagement and disengagement. The engine should not stall or jump forward.

[Primary adjustment]

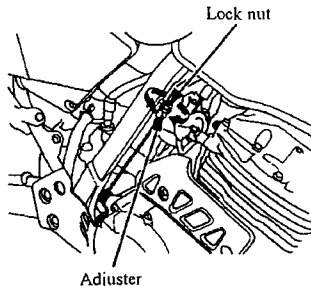

[Secondary adjustment]

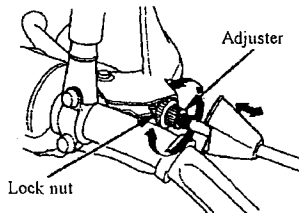

Fuses in the fuse box

1. Remove left side cover
2. Remove fuse box cover by releasing its catch.
3. Locate the blown fuse. There are some spare fuses in the box.
4. Re-install fuse box cover and left side cover.

Main fuse

1. Remove left side cover.
2. Disconnect starter magnetic switch coupler.
3. Pull out the main fuse to check it. A spare fuse is stored underneath the starter magnetic switch.
4. Reconnect the coupler and install the side cover.

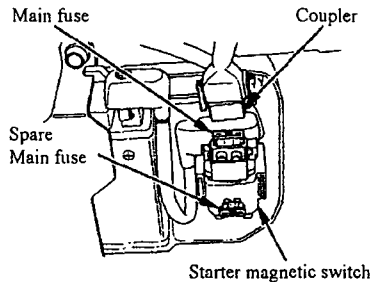
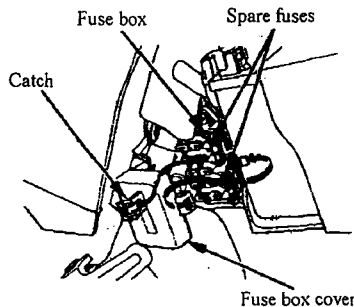

Fuses

Fuse inspection/replacement

Turn off the ignition switch and make sure that the fuses are not blown. If any of the fuses are blown, replace with a fuse of the same rating. Use of over-rated fuses may result in damage to the wiring or sensitive components.

If the replaced fuse blows again, further troubleshooting should be carried out. Replace the fuse only after identifying and rectifying the defect.

Tips:

When installing electrical parts, always use genuine Honda parts and accessories. Other brands may overload the circuit blow fuses or flatten the battery.

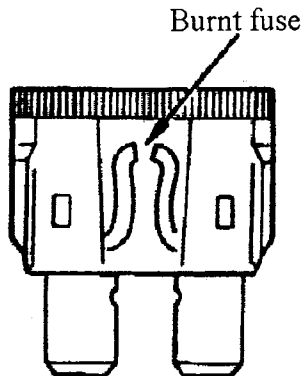

Tyres

For your own comfort and safety, always maintain tyres in good condition. Correct tyre pressure should be maintained at all times. Tyres worn beyond the wear indicator limit should be replaced as soon as possible.

Warning:

Excessively worn tyres and inappropriate tyre pressures may lead to an accident with fatal or serious injury.

Always observe the tyre pressure range and replace tyres worn beyond the wear indicator limits.

Tyre pressure adjustment

Measure while the tyre is cold:

Without pillion passenger	Front	150kPa(1.50kgf/cm ²)
Without pillion passenger	Rear	150kPa(1.50kgf/cm ²)
With pillion passenger	Front	150kPa(1.50kgf/cm ²)
With pillion passenger	Rear	150kPa(1.50kgf/cm ²)

Wear indicator check

Tyre Tread depth can be checked by looking at the wear indicator. If the wear indicators come out to the surface, replace the tyre as soon as possible.

In addition to this, for your safe riding, always replace the tyre if the tread centre depth become less than the figures below:

Front tyre: 3.0mm

Rear tyre: 3.0mm

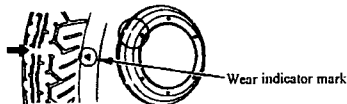

Replacement tyre selection

When replacing tyres, always use appropriate tyres for this model motorcycle. Use of inappropriate tyres may seriously affect the controllability and stability of the motorcycle.

Please consult your local Honda dealer for the tyre change.

Front	Size	3.00 - 21 51 P
Front	Type	Dunlop D605FG with tube
Rear	Size	4.60 - 18 63 P
Rear	Type	Dunlop D605G with tube

Warning:

Use of inappropriate tyres may seriously affect the controllability and stability of the motorcycle. It may result in an accident leading to fatal or serious injuries.

Always use the correct tyres only.

Air filter

Replacing the air filter element

1. Turn quick-release screws 90deg.to the left to unlock and open the air filter cover.
2. Unhook the set spring and take out the air filter element.
3. Firmly insert the replacement air cleaner element.
4. Refit the air-filter cover and secure the quick-release screws.

Tips:

- If the air filter element is loose, dust and debris may enter the intake manifold and wear the cylinder, resulting in reduced performance and reduced engine life.
- Avoid applying water to the air filter when washing your motorcycle. Water in the air filter may cause engine starting trouble.

Quick screws

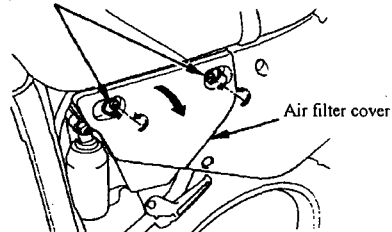

Air filter element

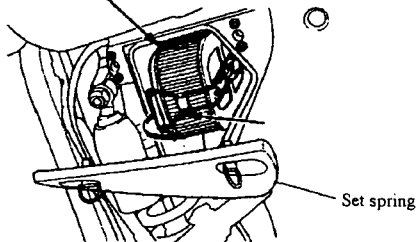

Engine Breather drain

The engine, the muffler and the exhaust pipe may be extremely hot immediately after stopping the engine. Watch out for burn injury when carrying out the maintenance.

Breather drain cleaning

1. Place an oil pan underneath the breather drain.
2. Remove the drain plug and remove all build-ups inside the breather drain.
3. Refit the drain plug.

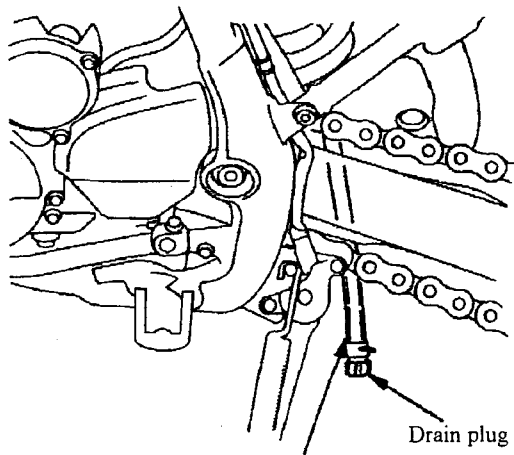

Breather drain

Drain plug

Engine troubleshooting

If the engine does not start or stalls, please check the following points:

- The engine is started in accordance with the starting procedure in this manual.
- There is sufficient fuel in the fuel tank.
- The engine stop switch is at RUN position. If the switch is at OFF position, please follow the procedure below:
 1. Leave the engine stop switch at OFF position.
 2. Fully push in the choke lever.
 3. Fully open the throttle.
 4. Turn the ignition switch ON.
 5. Engage starter for 5 to 10 seconds to crank the engine.
 6. Now set the engine stop switch to RUN position and follow the starting procedure described elsewhere in this manual.

Repair/Maintenance

- Please contact your Honda dealer for repairs and maintenance.
- The best way to maximise your motorcycle's life is to have it regularly serviced by an authorised Honda dealer.

Noise Warning

Noise Control System (Australia Only)

TAMPERING WITH THE NOISE
CONTROL SYSTEM IS PROHIBITED:

Owners are warned that the law may
prohibit:

- (a) The removal or rendering inoperative by any person other than for purposes of maintenance, repair, or replacement, of any device or element of design incorporated into any new motorcycle for the purpose of noise control prior to its sale or delivery to the ultimate purchaser or while it is in use: and
- (b) The use of the motorcycle after such device or element of design has been removed or rendered inoperative by any person.

Specifications

Model	BA-MD30
Length	2,140mm
Width	820mm
Height	1,195mm
Wheelbase	1,420mm
Engine Type	Petrol engine, 4 stroke 0.249ltrs
Vehicle weight	130kg
Maximum capacity	2 persons
Tyre size Front	3.00-21 51P
Tyre size Rear	4.60-18 63P
Ground Clearance	270mm
Minimum turn radius	2.1m
Compression ratio	9.3
Maximum power output	21kW(28PS) @8,000rpm
Maximum torque	25Nm(2.6kgm) @7,000rpm
Fuel tank capacity	9.7 ltrs

Ignition Type	CDI battery ignition
Ignition Timing	BTDC 8(deg) @1,300rpm
Idling speed	1,300rpm
Spark plug (NGK)	CR7EH 9 / CR8EH 9 / CR9EH 9
Spark plug (ND)	U22FER9 / U24FER9 / U27FER9
Primary reduction	3.1
Clutch type	Wet-multi-plate coil spring
Transmission Type	Constant Mesh
Gear shift operation	left-foot operated
Gear Ratio 1 st	2.769
Gear Ratio 2 nd	1.882
Gear Ratio 3 rd	1.38
Gear Ratio 4 th	1.083
Gear Ratio 5 th	0.923
Gear Ratio 6th	0.814
First reduction	3.076

Specifications

Drive chain slack	30-40mm
Tyre pressure Single rider (Front)	150kPa (1.50kgf/cm ²)
Tyre pressure Single rider (Rear)	150kPa (1.50kgf/cm ²)
Tyre pressure with Pillion passenger (Front)	150kPa (1.50kgf/cm ²)
Tyre pressure with Pillion passenger (Rear)	150kPa (1.50kgf/cm ²)
Engine oil total capacity	1.7 ltrs
Engine oil qty upon filter change	1.4 ltrs
Engine oil qty upon oil change	1.3 ltrs
Clutch lever free play	10-20mm
Main fuse	20A
Other fuses	5A, 15A
Spark plug gap	0.8-0.9mm
Air filter	filter paper (viscous type)
Head lamp	12V 60/55W
Front indicator lamps	12V 15W
Rear indicator lamps	12V 15W
Stop/tail lamp	12V 21/5W