

Z50R

**1985
HONDA**

**OWNER'S
MANUAL**

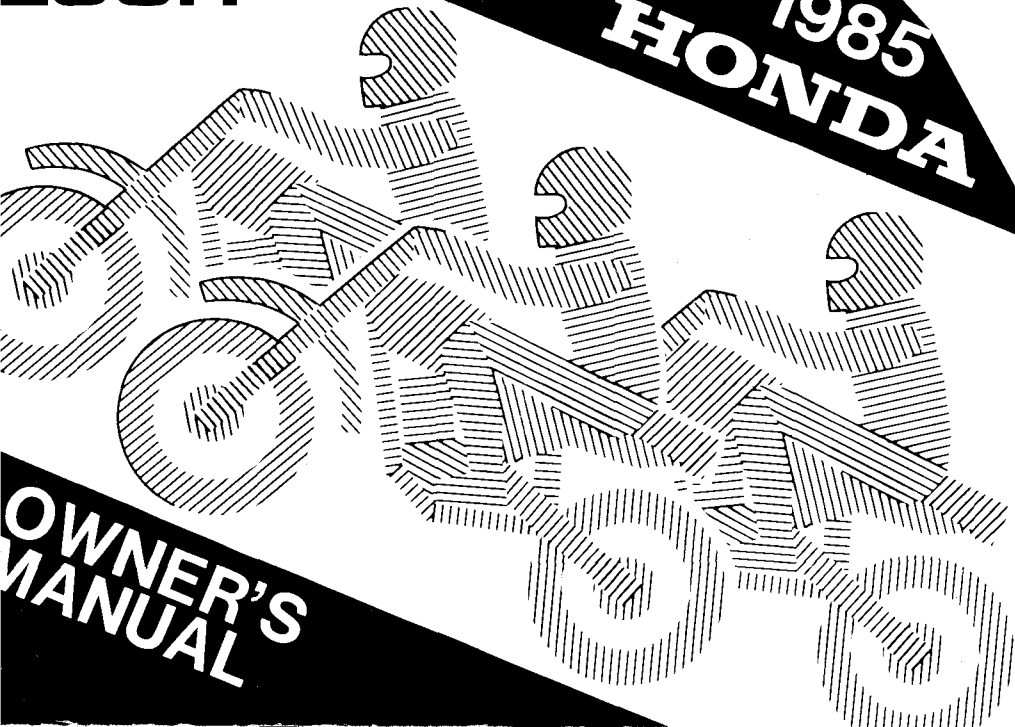

IMPORTANT NOTICE

- **OPERATOR ONLY. NO PASSENGER.**

This motorcycle is designed and constructed as an operator only model. The seating configuration does not safely permit the carrying of a passenger. Do not exceed the vehicle capacity load as shown on the tire information label.

- **FOR OFF-ROAD USE ONLY.**

This motorcycle is designed and manufactured for off-road use only. Obey local laws and regulations.

- **READ OWNER'S MANUAL CAREFULLY.**

- **NOT RECOMMENDED FOR CHILDREN UNDER 7 YEARS OLD.**

Pay special attention to statements preceded by the following words.

 **WARNING**

Indicates a strong possibility of severe personal injury or loss of life if instructions are not followed.

CAUTION:

Indicates a possibility of personal injury or equipment damage if instructions are not followed.

NOTE:

Gives helpful information.
This manual should be considered a permanent part of the motorcycle and should remain with the motorcycle when resold.

**HONDA Z50R
OWNER'S MANUAL**

1985

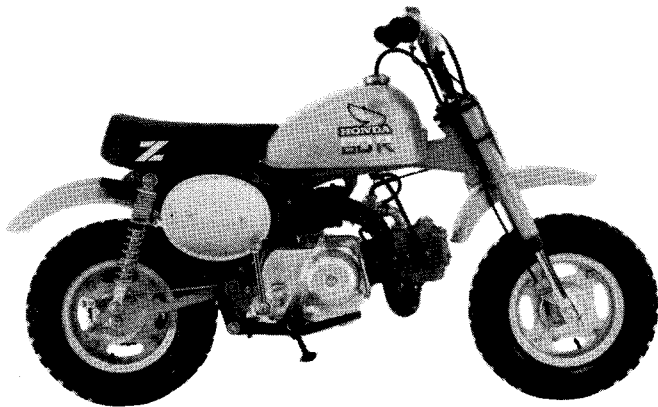

All information in this publication is based on the latest product information available at the time of approval for printing. HONDA MOTOR CO., LTD. reserves the right to make changes at any time without notice and without incurring any obligation. No part of this publication may be reproduced without written permission.

© Honda Motor Co., Ltd. 1984

WELCOME,

The motorcycle presents you a challenge to master the machine, a challenge to adventure. You can ride over many types of terrain on a vehicle that responds to your commands as no other does. Unlike an automobile, there is no metal cage around you. Like an airplane, a pre-ride inspection and regular maintenance are essential to your safety. Your reward is freedom.

To meet the challenges safely, and to enjoy the adventure fully, you should become thoroughly familiar with this owner's manual **BEFORE YOU RIDE THE MOTORCYCLE.**

When service is required, remember that your Honda dealer knows your motorcycle best. If you have the required mechanical "know-how" and tools, your dealer can supply you with an official Honda Shop Manual to help you perform many maintenance and repair tasks.

Pleasant riding, and thank you for choosing a Honda!

CONTENTS

	Page		Page
MOTORCYCLE SAFETY	1	Contact Breaker Point Gap and Ignition Timing	29
Message To Parents	2	Valve Clearance	30
Protective Apparel	4	Cam Chain	32
Modifications	4	Air Cleaner	33
Loading and Accessories	5	Spark Arrester	34
DESCRIPTION	6	Throttle Cable	35
Parts Location	6	Carburetor	36
Serial Numbers	9	Fuel Filter	37
Color label	10	Clutch	37
Parts Function	10	Drive Chain	38
Fuel	11	Front Brake	42
Engine Oil	13	Rear Brake	44
Tires	15	Front Suspension	45
OPERATION	17	Rear Suspension	46
Pre-ride Inspection	17	Side Stand	46
Starting the Engine	18	Front Wheel Removal	47
Break-in	20	Rear Wheel Removal	48
Riding	20	CLEANING	49
Braking	22	STORAGE GUIDE	50
Parking	22	NOISE EMISSION CONTROL SYSTEM (USA ONLY)	52
Tool Kit	23	SPECIFICATIONS	53
MAINTENANCE	24		
Maintenance Schedule	25		
Engine Oil	27		
Spark Plug	28		

MOTORCYCLE SAFETY

Read these **WARNING LABELS** before you ride!

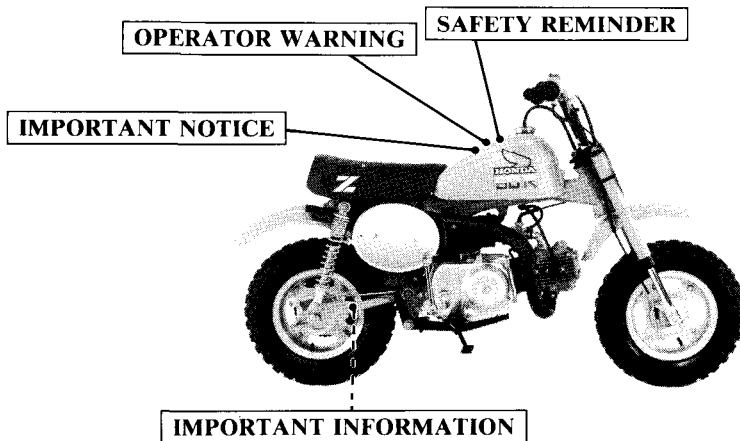

MESSAGE TO PARENTS

This motorcycle is designed for junior riders (rider weight of **150 pounds** or less). It is a fine learning motorcycle as long as the following precautions are observed:

- * The parent or instructor must be fully familiar with the motorcycle, the motorcycle controls, and the control functions before starting to teach a junior rider. Both instructor and student must fully understand everything in this manual before riding instruction begins.
- * The Z50R is an **OPERATOR ONLY** model. The rider weight limit of **150 pounds** must be observed.
- * The student rider must be of sufficient size to hold the motorcycle up while straddling it with both feet on the ground. The rider must also have

sufficient strength to pick up the motorcycle if it is on its side.

- * The practice location must be a level, uncongested off-road area free of obstacles.
- * It is illegal to ride the Z50R on public streets, roads or highways. It must be ridden only in off-road areas where such activities are permitted. If it becomes necessary to cross a public roadway, remember to get off the Z50R and push it across.
- * For safety, the Z50R must be properly maintained. Be sure to make a "Pre-ride Inspection" before riding and be sure to impress the student rider with the importance of checking all the items thoroughly before riding the motorcycle.

- * A prime objective in the instruction process is developing the student's self-confidence. This self-confidence comes with a total familiarization with the motorcycle controls and their functions, plus lots of PRACTICE.
 - * Always obey local off-road riding laws and regulations.
 - * Obtain permission to ride on private property. Avoid posted areas and obey "no trespassing" signs.
 - * When basic riding techniques have been mastered by the young rider remember these next few words of caution: The young rider should always ride in the company of an adult on another motorcycle so they can assist each other in the event of trouble.
 - * Familiarity with the motorcycle is critically important should a problem occur far from help.
 - * Caution the young rider never to ride beyond his ability and experience or faster than conditions warrant.
- * If you are not familiar with the terrain lead the way and ride cautiously. Hidden rocks, holes or ravines could spell trouble.

PROTECTIVE APPAREL

1. Most motorcycle accident fatalities are due to head injuries: **ALWAYS** wear a helmet. You should also wear a face shield or goggles, boots, gloves, and protective clothing.
2. The exhaust system becomes very hot during operation, and it remains hot after operation. Never touch any part of the hot exhaust system. Wear clothing that fully covers your legs.
3. Do not wear loose clothing which could catch on the control levers, kickstarter, footpegs, drive chain, or wheels.

MODIFICATIONS

WARNING

- * *Modification of the motorcycle, or removal of original equipment, may render the vehicle unsafe or illegal. Obey all federal, state, and local equipment regulations.*
- * *Spark arresters and mufflers are required in most areas. Don't modify your exhaust system.*
- * *Remember that excessive noise bothers everyone and creates a bad image for motorcycling.*

LOADING AND ACCESSORIES

WARNING

* *A motorcycle is sensitive to changes in weight distribution. Improper loading of cargo and mounting of accessories can impair the motorcycle's stability and performance. To prevent an accident, use extreme care when mounting accessories and riding with cargo.*

These general guidelines may help you decide whether or how to equip your motorcycle:

The vehicle capacity load is **150 lbs.** The combined weight of the rider and cargo must not exceed this limit.

1. Keep cargo and accessory weight low and close to the center of the motorcycle. Load weight equally on both sides to minimize imbalance. As weight is located farther from the motorcycle's center of gravity, handling is proportionally affected.

2. All cargo and accessories must be secure for stable handling. Recheck security frequently.
3. Do not attach large or heavy items to the handlebars, front forks, or fender. Unstable handling or slow steering response may result.

DESCRIPTION

PARTS LOCATION

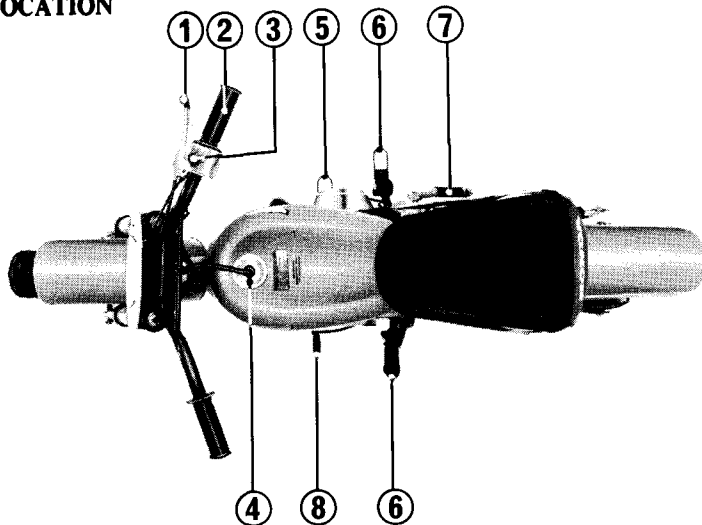

(1) Front brake lever
(5) Rear brake pedal

(2) Throttle grip
(6) Footpeg

(3) Engine stop switch
(7) Kickstarter

(4) Fuel tank cap
(8) Gearshift pedal

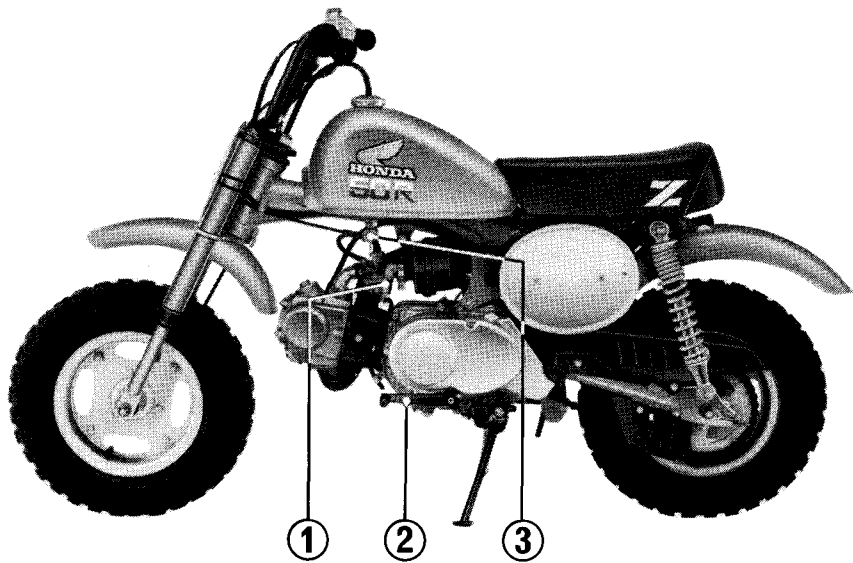

(1) Choke lever

(2) Gearshift pedal

(3) Fuel valve

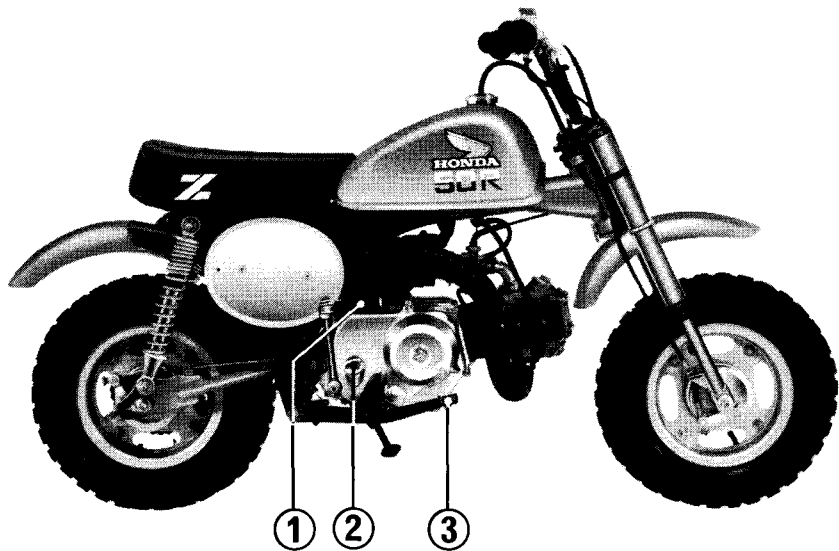

(1) Kickstarter

(2) Oil filler cap

(3) Rear brake pedal

SERIAL NUMBERS

The frame and engine serial numbers are required when registering your motorcycle. They may also be required by your dealer when ordering replacement parts. The frame serial number (1) is stamped on the left of the steering head.

FRAME NO. _____

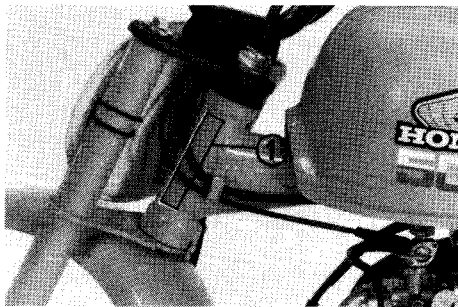

(1) Frame serial number

The engine serial number (2) is located on the left side of the engine. Record the numbers here for your reference.

ENGINE NO. _____

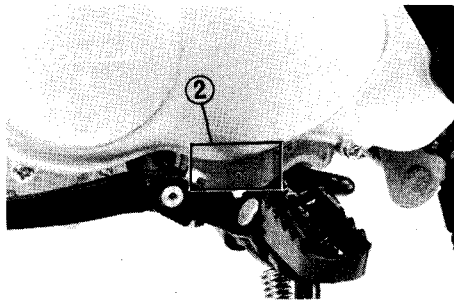

(2) Engine serial number

COLOR LABEL

The color label (1) is attached to the frame below the seat. It is helpful when ordering replacement parts. Record the color and code here for your reference.

COLOR _____

CODE _____

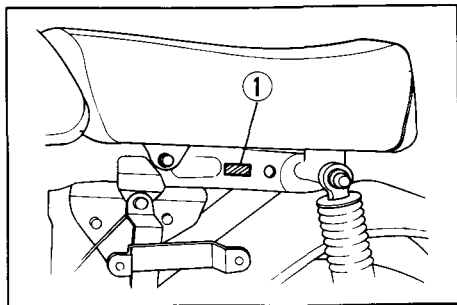

(1) Color label

PARTS FUNCTION

Engine Stop Switch

The three-position engine stop switch (1) is next to the throttle grip. When the switch is in the RUN position, the engine will operate. When the switch is in either OFF position the engine will not operate.

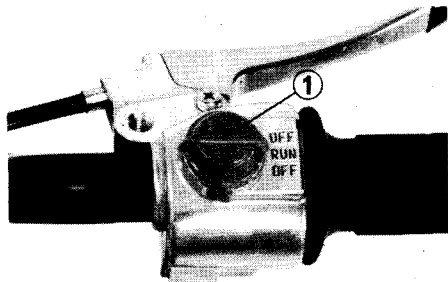

(1) Engine stop switch