

HONDA
POWER PRODUCTS

GENERATOR EX7



OWNER'S MANUAL

Honda EX7

OWNER'S MANUAL



The "e-SPEC" mark symbolizes environmentally responsible technologies applied to Honda power equipment, which contains our wish to "preserve nature for generations to come."

Thank you for purchasing a Honda generator.

This manual covers operation and maintenance of the EX7 generator.

All information in this publication is based on the latest product information available at the time of approval for printing.

Honda Motor Co., Ltd. reserves the right to make changes at any time without notice and without incurring any obligation.

No part of this publication may be reproduced without written permission.

This manual should be considered a permanent part of the generator and should remain with it if it is resold.

Pay special attention to statements preceded by the following words:

▲WARNING Indicates a strong possibility of severe personal injury or death if instructions are not followed.

CAUTION: Indicates a possibility of personal injury or equipment damage if instructions are not followed.

NOTE: Gives helpful information.

If a problem should arise, or if you have any questions about the generator, consult an authorized Honda dealer.

▲WARNING

Honda generator is designed to give safe and dependable service if operated according to instructions. Read and understand the Owner's Manual before operating the generator. Failure to do so could result in personal injury or equipment damage.

- The illustration may vary according to the type.

CONTENTS

1. SAFETY INSTRUCTIONS	3
2. SAFETY LABEL LOCATIONS	7
CE mark and noise label locations.....	11
3. COMPONENT IDENTIFICATION.....	12
4. PRE-OPERATION CHECK.....	14
5. STARTING THE ENGINE	19
• Carburetor Modification for High Altitude Operation	
6. GENERATOR USE	23
7. STOPPING THE ENGINE	31
8. MAINTENANCE	33
9. TRANSPORTING/STORAGE.....	38
10. TROUBLESHOOTING.....	40
11. SPECIFICATIONS.....	42
12. WIRING DIAGRAM	44
13. MAJOR Honda DISTRIBUTOR ADDRESSES	48

1. SAFETY INSTRUCTIONS

IMPORTANT SAFETY INFORMATION

Honda generators are designed for use with electrical equipment that has suitable power requirements. Other uses can result in injury to the operator or damage to the generator and other property.

Most injuries or property damage can be prevented if you follow all instructions in this manual and on the generator. The most common hazards are discussed below, along with the best way to protect yourself and others.

Never attempt to modify the generator. It can cause an accident as well as damage to the generator and appliances.

- Do not connect an extension to the muffler.
- Do not modify the intake system.
- Do not adjust the governor.
- Do not remove the control panel or do not change the wiring of the control panel.

Operator Responsibility

Know how to stop the generator quickly in case of emergency.

Understand the use of all generator controls, output receptacles, and connections.

Be sure that anyone who operates the generator receives proper instruction. Do not let children operate the generator without parental supervision.

Be sure to observe the instructions in this manual for how to use the generator and maintenance information. Ignoring or improperly following the instructions can cause an accident such as an electric shock, and the condition of the exhaust gas may deteriorate.

Place the generator on a firm level place before operation.

Do not operate the generator with any cover removed. You may get your hand or foot caught in the generator and it may cause accident.

Consult your authorized Honda dealer for disassembly and service of the generator that are not covered in this manual.

Carbon Monoxide Hazards

Exhaust contains poisonous carbon monoxide, a colorless, odorless gas. Breathing exhaust can cause loss of consciousness and may lead to death.

If you run the generator in an area that is confined, or even partially enclosed area, the air you breathe could contain dangerous amount of exhaust gas.

Never run your generator inside a garage, house, or near open windows or doors.

Electric Shock Hazards

The generator produces enough electric power to cause a serious shock or electrocution if misused.

Using a generator or electrical appliance in wet conditions, such as rain or snow, or near a pool or sprinkler system, or when your hands are wet, could result in electrocution.

Keep the generator dry.

If the generator is stored outdoors, unprotected from the weather, check all of the electrical components on the control panel before each use. Moisture or ice can cause a malfunction or short circuit in electrical components that could result in electrocution.

If you get an electric shock, consult a doctor and have medical treatment immediately.

Do not connect to a building's electrical system unless an isolation switch has been installed by a qualified electrician.

Fire and Burn Hazards

Do not use the generator in areas with a high risk of fire.

When installed in ventilated rooms, additional requirements for fire and explosion protection shall be observed.

The exhaust system gets hot enough to ignite some materials.

- Keep the generator at least 1 meter (3 feet) away from buildings and other equipment during operation.
- Do not enclose the generator in any structure.
- Keep flammable materials away from the generator.

Some parts of the internal combustion engine are hot and may cause burns. Pay attention to the warnings on the generator.

The muffler becomes very hot during operation and remains hot for a while after stopping the engine. Be careful not to touch the muffler while it is hot. Let the engine cool before storing the generator indoors.

Do not pour the water directly on the generator to put out the fire when it occurs. Use an appropriate fire extinguisher specially designed for electric fire or oil fire.

If you inhale fumes produced by an accidental fire with the generator, consult a doctor and have medical treatment immediately.

Refuel With Care

Gasoline is extremely flammable, and gasoline vapor can explode. Allow the engine to cool if the generator has been in operation.

Refuel only outdoors in a well ventilated area with the engine OFF.

Do not overfill the fuel tank.

Never smoke near gasoline, and keep other flames and sparks away.

Always store gasoline in an approved container.

Make sure that any spilled fuel has been wiped up before starting the engine.

Disposal

To protect the environment, do not dispose of the used generator, battery, engine oil, etc. carelessly by leaving them in the waste. Observe the local laws or regulations or consult your authorized Honda generator dealer to dispose of these parts.

Please dispose of used motor oil in a manner that is compatible with the environment. We suggest you take it in a sealed container to your local service station for reclamation. Do not throw it in the trash or pour it on the ground.

An improperly disposed battery can hurt the environment. Always confirm local regulations for battery disposal. Contact your Honda servicing dealer for a replacement.

2. SAFETY LABEL LOCATIONS

These labels warn you of potential hazards that can cause serious injury. Read the labels and safety notes and precautions described in this manual carefully.

If a label comes off or becomes hard to read, contact your Honda dealer for a replacement.

[For Australian model: U type]

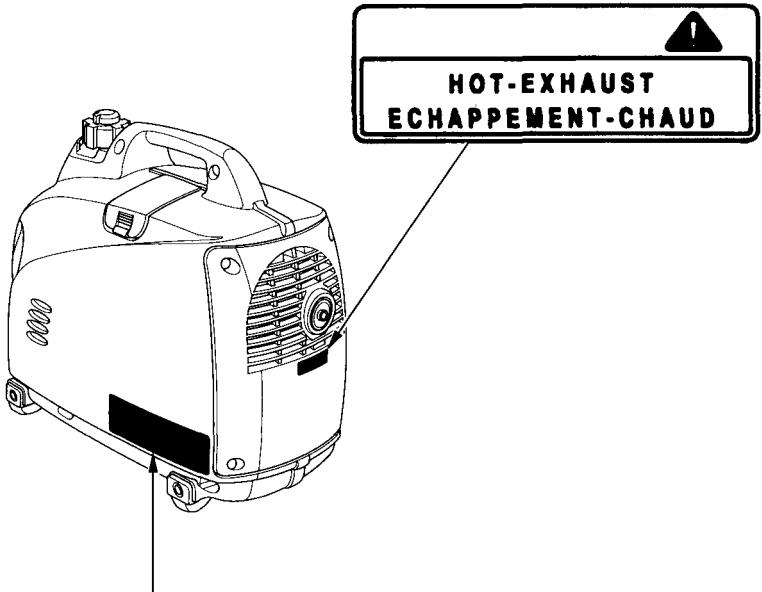

⚠ CAUTION

- DO NOT USE INDOORS DUE TO DANGER OF CARBON MONOXIDE POISONING.
- DO NOT CONNECT THE OUTLET OF THIS GENERATOR TO HOUSE WIRING.
- STOP THE ENGINE BEFORE REFUELING.
- CHECK FOR SPILLED FUEL OR FUEL LEAKS.
- DO NOT FILL THE FUEL TANK BEYOND THE UPPER LIMIT LINE.
- FOR DETAILED EXPLANATION, READ THE OWNER'S MANUAL.
- WHEN STORED OR IN TRANSIT, MAKE CERTAIN THAT THE ENGINE SWITCH AND THE FUEL TANK CAP LEVER ARE IN "OFF" POSITION TO PREVENT FUEL LEAKS.

⚠ ATTENTION

- NE PAS UTILISER DANS UN LOCAL CLOS OU LES VAPEURS NOCIVES DE MONOXIDE DE CARBONE PEUVENT S'ACCUMULER.
- NE JAMAIS CONNECTER LE GROUPE ELECTROGENE A UNE PRISE DE SECTEUR.
- ARRÊTER LE MOTEUR AVANT DE FAIRE LE PLEIN D'ESSENCE.
- CONTROLER OÙ IL N'Y A NI FUITE D'ESSENCE, NI D'ESSENCE REPARQUÉ SUR L'APPAREIL.
- NE PAS REMPLIR LE RESERVOIR D'ESSENCE AU-DESSUS DU REPERE DE NIVEAU MAXIMUM.
- POUR PLUS D'INFORMATIONS, LIRE LE MANUEL DE L'UTILISATEUR.
- QUAND LE GROUPE ELECTROGENE EST REMISE OU TRANSPORTE, S'ASSURER QUE LE CONTACT D'ARRÊT DU MOTEUR ET LA MISE A L'AIR LIBRE DU RESERVOIR D'ESSENCE SONT SUR LA POSITION "OFF" AFIN D'ÉVITER TOUTE FUITE D'ESSENCE.

3. COMPONENT IDENTIFICATION

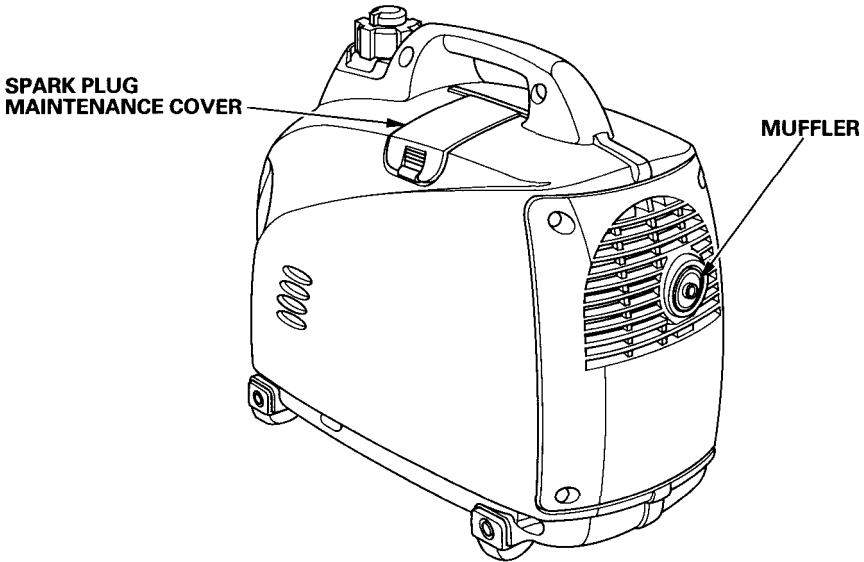
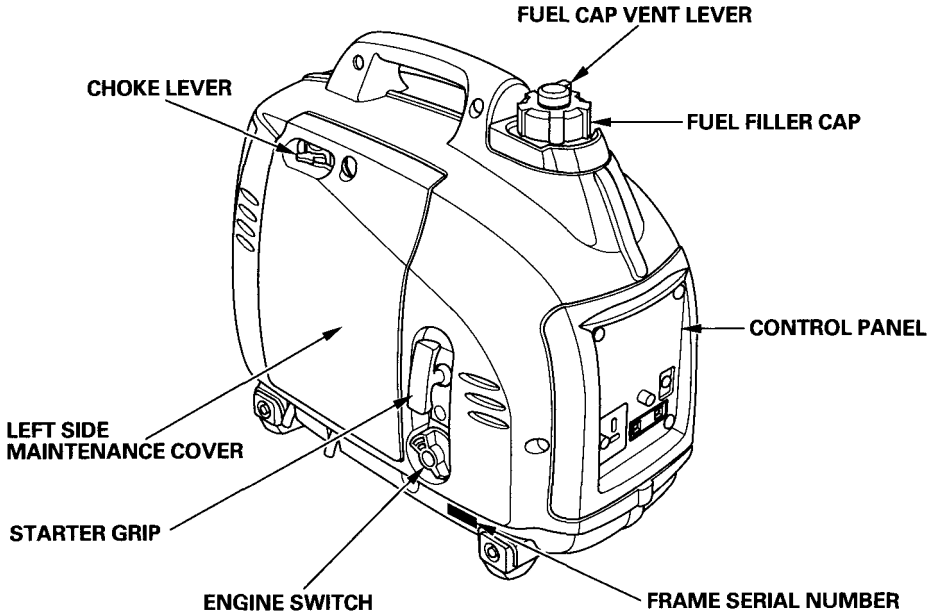

Record the frame serial number in the space below. You will need this serial number when ordering parts.

Frame serial number: _____

CONTROL PANEL

U type

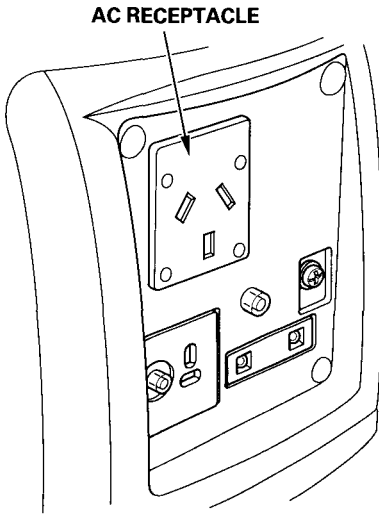

4. PRE-OPERATION CHECK

CAUTION:

Be sure to check the generator on a level surface with the engine stopped.

1. Check the engine oil level.

CAUTION:

Using non detergent oil or 2-stroke engine oil could shorten the engine's service life.

Recommended oil

Use 4-stroke motor oil that meets or exceeds the requirements for API service category SE or later (or equivalent). Always check the API service label on the oil container to be sure it includes the letters SE or later (or equivalent).

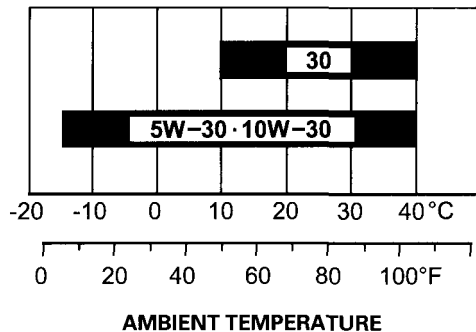

SAE 10W-30 is recommended for general use. Other viscosities shown in the chart may be used when the average temperature in your area is within the indicated range.

Loosen the cover screw and remove the left side maintenance cover. Remove the oil filler cap, and wipe the dipstick with a clean rag. Check the oil level by inserting the dipstick in the filler hole without screwing it in.

If the oil level is below the end of the dipstick, refill with recommended oil up to the top of the oil filler neck.

Reinstall the oil filler cap/dipstick securely.

CAUTION:

Running the engine with insufficient oil can cause serious engine damage.

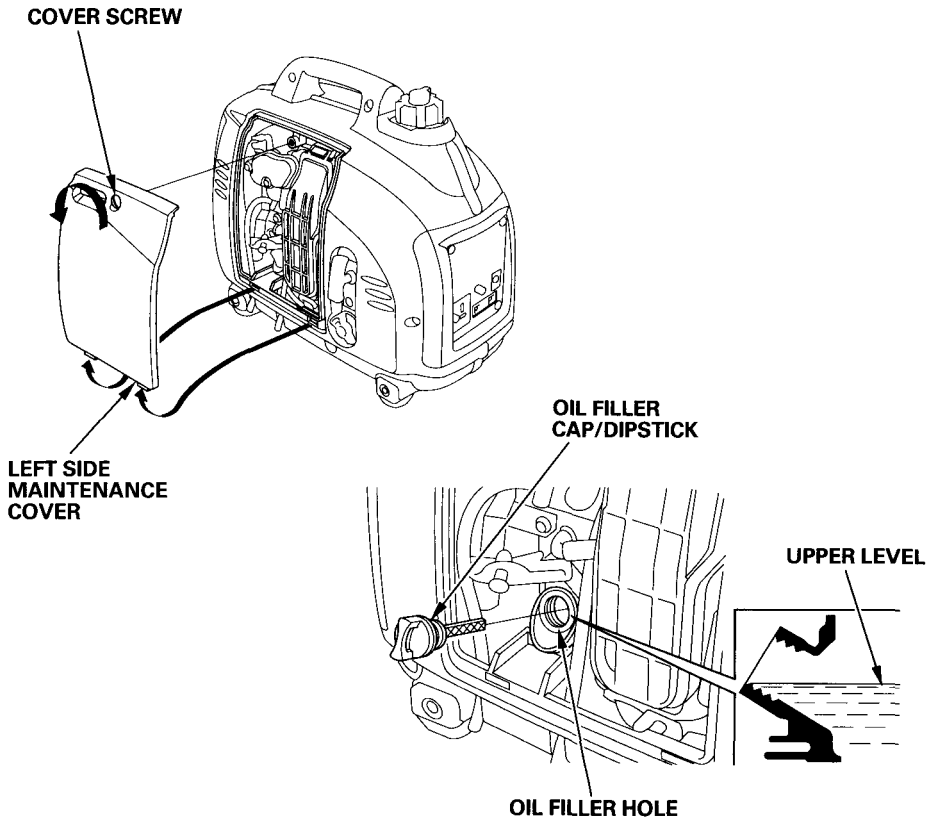

NOTE:

The Oil Alert System will automatically stop the engine before the oil level falls below the safe limit. However, to avoid the inconvenience of an unexpected shutdown, it is still advisable to visually inspect the oil level regularly.

2. Check the fuel level.

If the fuel level is low, refuel the fuel tank until the level as specified. After refueling, tighten the fuel filler cap securely.

Use automotive unleaded gasoline with a Research Octane Number of 91 or higher (a Pump Octane Number of 86 or higher). Never use stale or contaminated gasoline or an oil/gasoline mixture. Avoid getting dirt or water in the fuel tank.

▲WARNING

- **Gasoline is extremely flammable and is explosive under certain conditions.**
- **Refuel in a well ventilated area with the engine stopped. Do not smoke or allow flames or sparks in the area where the engine is refueled or where gasoline is stored.**
- **Do not overfill the fuel tank (there should be no fuel above the upper limit mark). After refueling, make sure the fuel filler cap is closed properly and securely.**
- **Be careful not to spill fuel when refueling. Spilled fuel or fuel vapor may ignite. If any fuel is spilled, make sure the area is dry before starting the engine.**
- **Avoid repeated or prolonged contact with skin or breathing of vapor.**

KEEP OUT OF REACH OF CHILDREN.

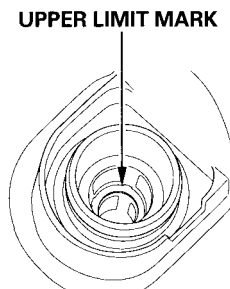
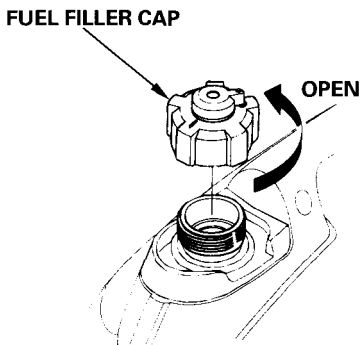

NOTE:

Gasoline spoils very quickly depending on factors such as light exposure, temperature and time.

In worst cases, gasoline can be contaminated within 30 days.

Using contaminated gasoline can seriously damage the engine (carburetor clogged, valve stuck).

Such damage due to spoiled fuel is disallowed from coverage by the warranty.

To avoid this please strictly follow these recommendations:

- Only use specified gasoline (see page 16).
- Use fresh and clean gasoline.
- To slow deterioration, keep gasoline in a certified fuel container.
- If long storage (more than 30 days) is foreseen, drain fuel tank and carburetor (see pages 38 and 39).

Gasolines Containing Alcohol

If you decide to use a gasoline containing alcohol (gasohol), be sure its octane rating is at least as high as that recommended by Honda. There are two types of "gasohol": one containing ethanol, and the other containing methanol.

Do not use gasohol that contains more than 10% ethanol. Do not use gasoline containing methanol (methyl or wood alcohol) that does not also contain cosolvents and corrosion inhibitors for methanol. Never use gasoline containing more than 5% methanol, even if it has cosolvents and corrosion inhibitors.

NOTE:

- Fuel system damage or engine performance problems resulting from the use of fuels that contain alcohol is not covered under the warranty.

Honda cannot endorse the use of fuels containing methanol since evidence of their suitability is as yet incomplete.

- Before buying fuel from an unfamiliar station, try to find out if the fuel contains alcohol, if it does, confirm the type and percentage of alcohol used.

If you notice any undesirable operating symptoms while using a gasoline that contains alcohol, or one that you think contains alcohol, switch to a gasoline that you know does not contain alcohol.

3. Check the air cleaner.

Check the air cleaner element to be sure it is clean and in good condition.

Loosen the cover screw and remove the left side maintenance cover. Press the latch tab on the top of the air cleaner body, remove the air cleaner cover, check the element.

Clean or replace the element if necessary (see page 35).

CAUTION:

Never run the engine without the air cleaner element. Rapid engine wear will result from contaminants, such as dust and dirt, being drawn through the carburetor, into the engine.

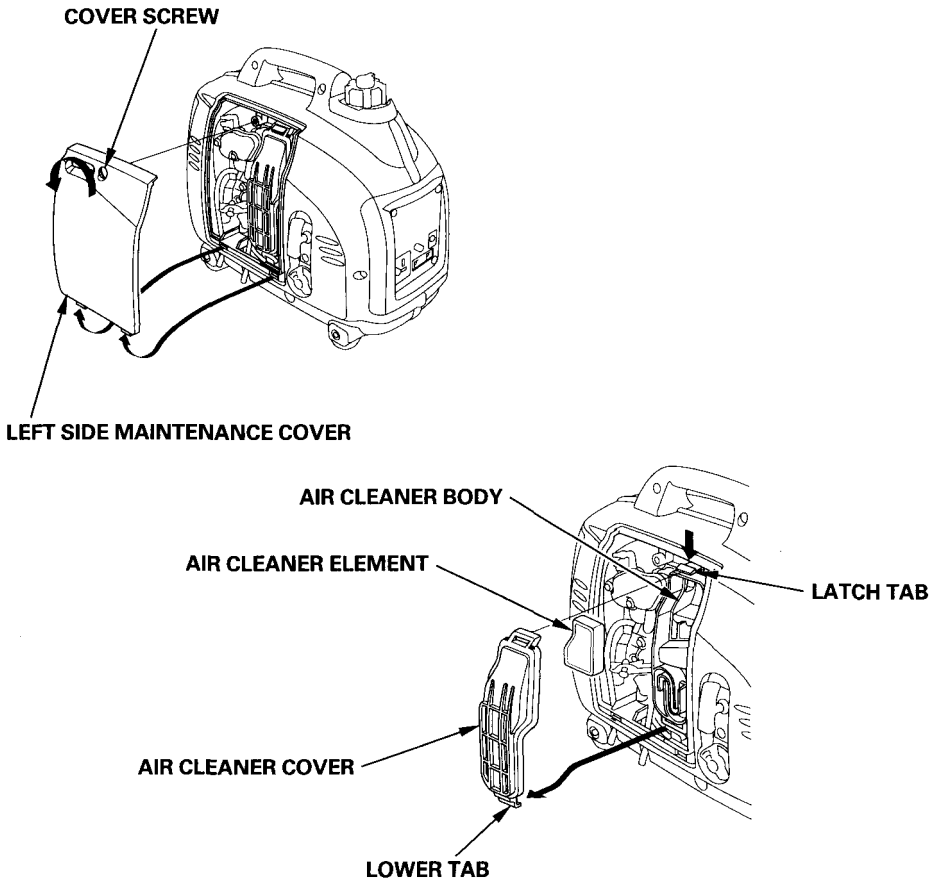

5. STARTING THE ENGINE

Before starting the engine disconnect any load from the AC receptacle.

1. Turn the fuel cap vent lever fully clockwise to the ON position.

NOTE:

Turn the fuel cap vent lever to the OFF position when transporting the generator.

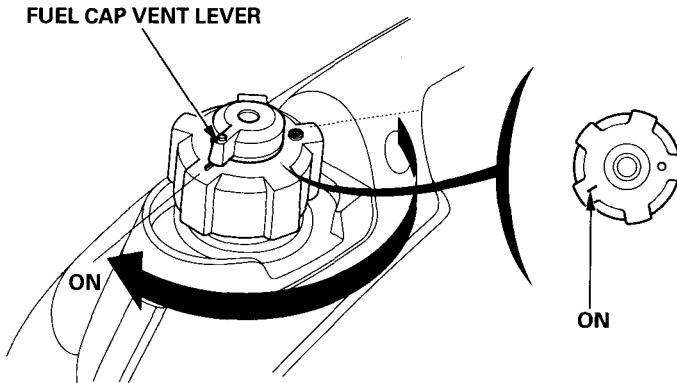

2. Turn the engine switch to the ON position.

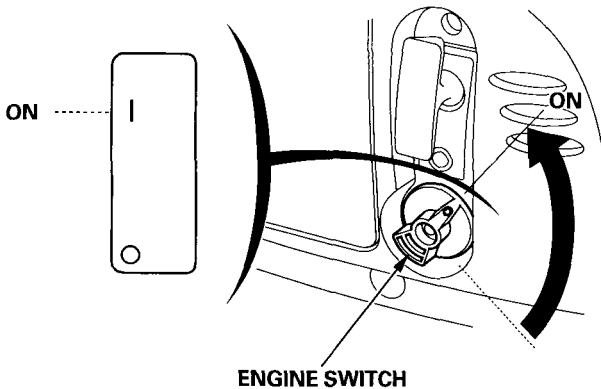

3. Move the choke lever to the CLOSED position.

NOTE:

Do not use the choke when the engine is warm or the air temperature is high.

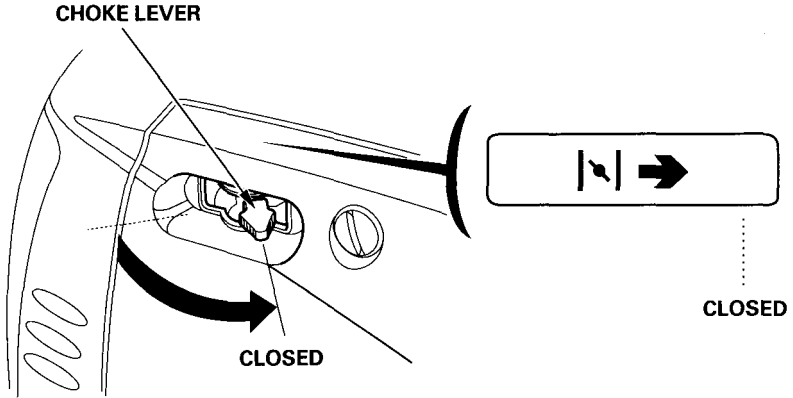

4. Pull the starter grip lightly until you feel resistance, then pull the starter grip briskly toward in the direction of the arrow as shown below.

CAUTION:

- The starter grip can be drawn back very quickly before you release it. This may pull your hand forcefully toward the engine and cause an injury.
- Do not allow the starter grip to snap back. Return it slowly by hand.

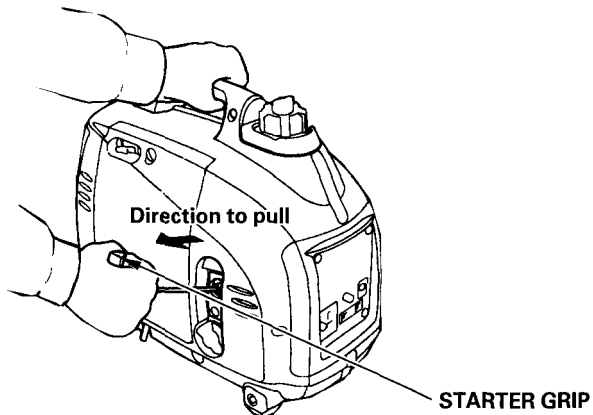

5. Move the choke lever to the OPEN position as the engine warms up.

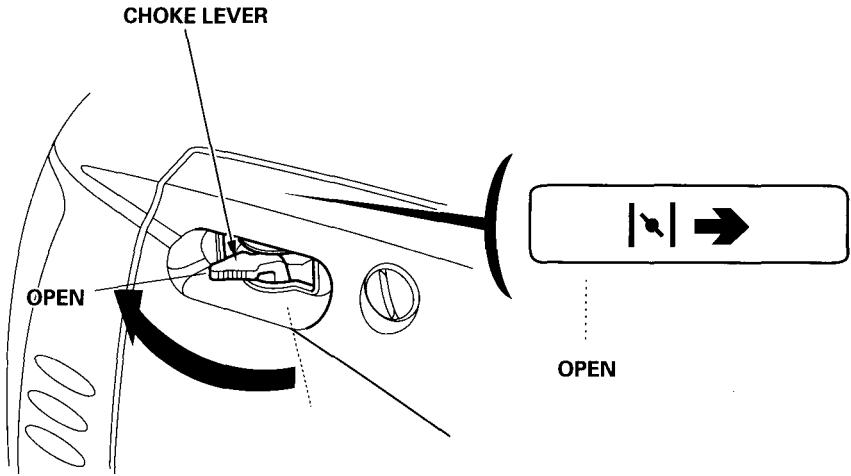

NOTE:

If the engine stops and will not restart, check the engine oil level (see page 14) before troubleshooting in other areas.

• Carburetor Modification for High Altitude Operation

At high altitude, the standard carburetor air-fuel mixture will be too rich. Performance will decrease, and fuel consumption will increase. A very rich mixture will also foul the spark plug and cause hard starting. Operation at an altitude that differs from that at which this engine was certified, for extended periods of time, may increase emissions.

High altitude performance can be improved by specific modifications to the carburetor. If you always operate your generator at altitudes above 1,500 meters (5,000 feet), have your authorized Honda servicing dealer perform this carburetor modification. This engine, when operated at high altitude with the carburetor modifications for high altitude use, will meet each emission standard throughout its useful life.

Even with carburetor modification, engine horsepower will decrease about 3.5% for each 300-meter (1,000-foot) increase in altitude. The effect of altitude on horsepower will be greater than this if no carburetor modification is made.

CAUTION:

When the carburetor has been modified for high altitude operation, the air-fuel mixture will be too lean for low altitude use. Operation at altitudes below 1,500 meters (5,000 feet) with a modified carburetor may cause the engine to overheat and result in serious engine damage. For use at low altitudes, have your servicing dealer return the carburetor to original factory specifications.

6. GENERATOR USE

Be sure to ground the generator when the connected equipment is grounded.

▲WARNING

- Do not connect to a building's electrical system unless an isolation switch has been installed by a qualified electrician.
- Connections for standby power to a building's electrical system must be made by a qualified electrician and must comply with all applicable laws and electrical codes. Improper connections can allow electrical current from the generator to back feed into the utility lines. Such back feed may electrocute utility company workers or others who contact the lines during a power outage, and when utility power is restored, the generator may explode, burn, or cause fires in the building's electrical system.

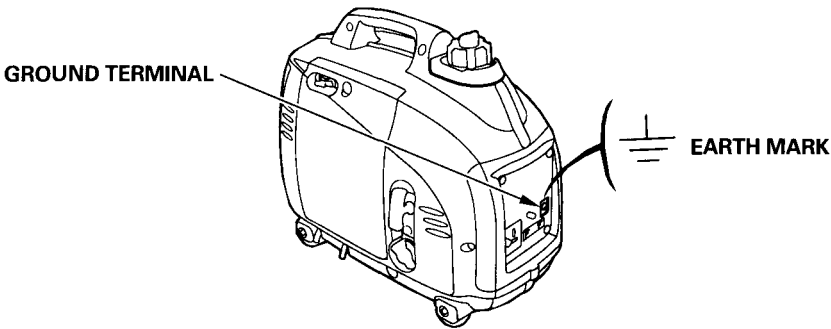

CAUTION:

- Do not exceed the current limit specified for any one receptacle.
- Do not connect the generator to a household circuit. This could cause the damage to the generator or to electrical appliances in the house.
- Do not modify or use the generator for other purposes than it is intended for. Also observe the following when using the generator.
- Do not connect an extension to the exhaust pipe.
When an extension cable is required, be sure to use a tough rubber sheathed flexible cable (IEC 245 or equivalent).
- Limit length of extension cables; 60 m (200 feet) for cables of 1.5 mm² (0.0023 in²) and 100 m (330 feet) for cables of 2.5 mm² (0.0039 in²). Long extension cables will lower usable power due to resistance in the extension cable.
- Keep the generator away from other electric cables or wires such as commercial power supply lines.

NOTE:

- The DC receptacle can be used while the AC power is in use.
If you use both at the same time, do not exceed the maximum AC power.
Maximum AC power: 0.5 kVA
- Most appliance motors require more than their rated wattage for startup.
- Make sure the electrical rating of the tool or appliance does not exceed that of the generator. Never exceed the maximum power rating of the generator. Power levels between rated and maximum may be used for no more than 30 minutes.
- Substantial overloading will switch OFF the AC circuit protector. Exceeding the time limit for maximum power operation or slightly overloading the generator may not switch the AC circuit protector OFF, but will shorten the service life of the generator.
- Limit operation requiring maximum power to 30 minutes.
Maximum power is: 0.7 kVA
- For continuous operation, do not exceed the rated power.
Rated power is: 0.6 kVA
- In either case, the total power requirements (VA) of all appliances connected must be considered.

AC applications

1. Start the engine and make sure the output indicator (green) comes on.
2. Confirm that the appliance to be used is switched off, and plug in the appliance.

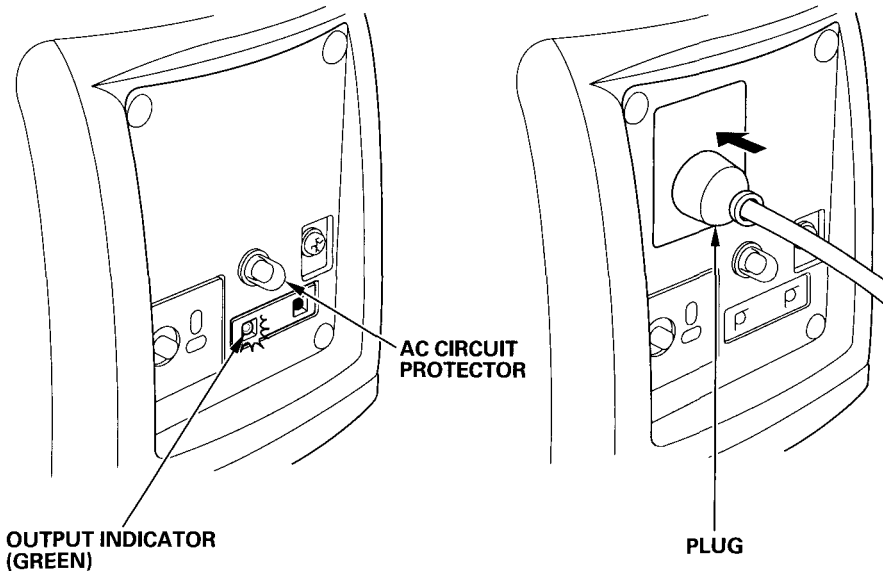

CAUTION:

- **Substantial overloading will switch off the circuit protector. Marginal overloading may not switch off the circuit protector, but it will shorten the service life of the generator.**
- **Be sure that all appliances are in good working order before connecting them to the generator. Electrical equipment (including lines and plug connections) should not be defective. If an appliance begins to operate abnormally, becomes sluggish, or stops suddenly, turn off the generator engine switch immediately. Then disconnect the appliance, and examine it for signs of malfunction.**

AC Circuit Protector

The AC circuit protector will automatically switch OFF (push button comes out) if there is a short circuit or a significant overload of the generator at receptacle.

If an AC circuit protector switch OFF automatically, check that the appliance is working properly and does not exceed the rated load capacity of the circuit before resetting the AC circuit protector ON (pushing the push button in).

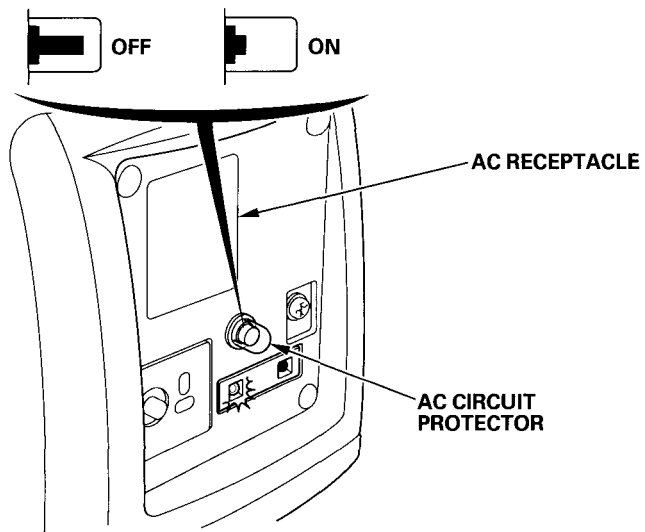

NOTE:

If an overloaded circuit trips the AC circuit protector, reduce the electrical load on the circuit, and wait a few minutes before resuming operation.

The yellow indicator inside the circuit protector button will pop out to show that the circuit protector has switched off. Push the button in to reset the circuit protector.

Output Indicator

The Output indicator (green) will remain ON during normal operating conditions.

If the output indicator (green) blinks, current to the connected appliance(s) will shut off.

When this happens, stop the engine and disconnect the appliance(s). Then restart the engine.

If the output indicator (green) blinks again, consult your Honda generator dealer.

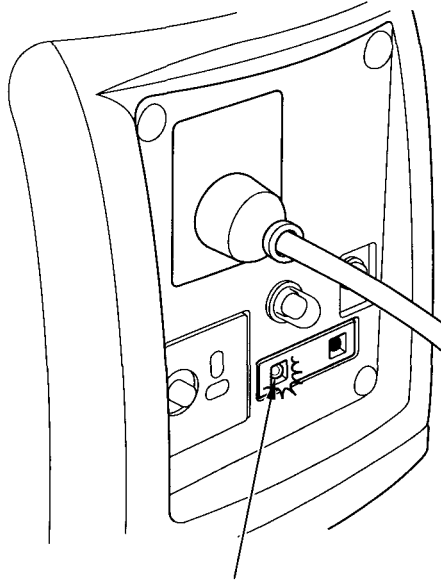

**OUTPUT INDICATOR
(GREEN)**

DC application

The DC receptacle may be used for charging 12 volt automotive-type batteries only.

1. Connect the charging cable to the DC receptacle of the generator and then to the battery terminals.

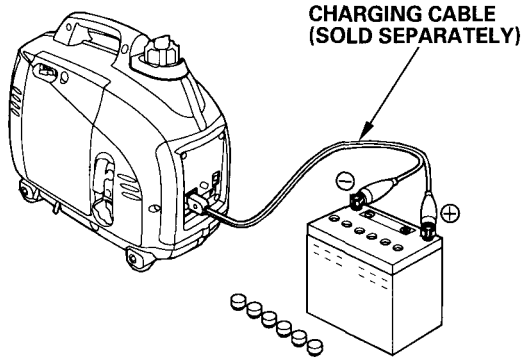

▲WARNING

- To prevent the possibility of creating a spark near the battery, connect charging cable first to the generator, then to the battery. Disconnect cable first at the battery.
- Before connecting charging cable to a battery that is installed in a vehicle, disconnect the vehicle's battery cable. Reconnect the vehicle's battery cable after the charging cables are removed. This procedure will prevent the possibility of a short circuit and sparks if you make accidental contact between a battery terminal and the vehicle's frame or body.

CAUTION:

- Do not attempt to start an automobile engine with the generator still connected to the battery. The generator may be damaged.
- Connect the positive battery terminal to the positive charging cord. Do not reverse the charging cables, or serious damage to the generator and/or battery may occur.

▲WARNING

- Batteries produce explosive gases: If ignited, and explosion can cause serious injury or blindness. Provide adequate ventilation when charging.
- **CHEMICAL HAZARD:** Battery electrolyte contains sulfuric acid. Contact with eyes or skin, even through clothing, may cause severe burns. Wear a faceshield and protective clothing.
- Keep flames and sparks away, and do not smoke in the area.
ANTIDOTE: If electrolyte gets into your eyes, flush thoroughly with warm water for at least 15 minutes and call a physician immediately.
- **POISON:** Electrolyte is poison.
ANTIDOTE
 - External: Flush thoroughly with water.
 - Internal: Drink large quantities of water or milk.
Follow with milk of magnesia or vegetable oil, and call a physician immediately.
- **KEEP OUT OF REACH OF CHILDREN.**

2. Start the engine.

NOTE:

- The DC receptacle can be used while the AC power is in use.
- An overload DC circuit will trip the DC circuit protector (push button comes out).
If this happens, wait a few minutes before pushing in the circuit protector to resume operation.

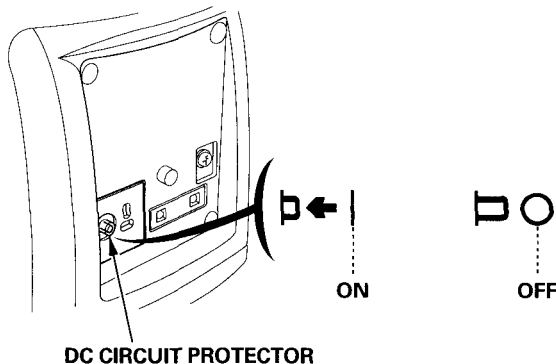

Oil Alert system

The Oil Alert system is designed to prevent engine damage caused by an insufficient amount of oil in the crankcase. Before the oil level in the crankcase falls below a safe limit, the Oil Alert system will automatically shut down the engine (the engine switch will remain in the ON position).

If the Oil Alert system shuts down the engine, the Oil Alert indicator (red) will come on when you operate the starter, and the engine will not run. If this occurs, check the engine oil level (see page 14).

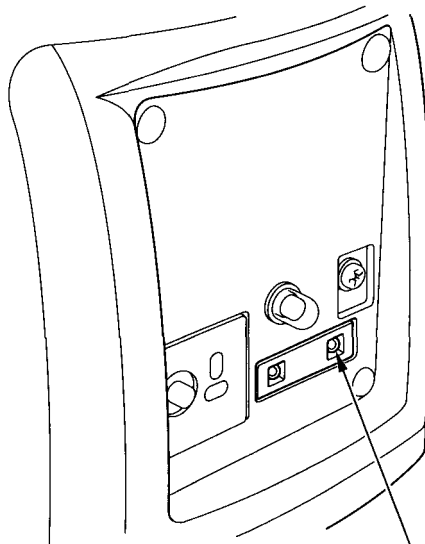

**OIL ALERT INDICATOR
(RED)**

7. STOPPING THE ENGINE

To stop the engine in an emergency, turn the engine switch to the OFF position.

IN NORMAL USE:

1. Switch off the connected equipment and pull the inserted plug.

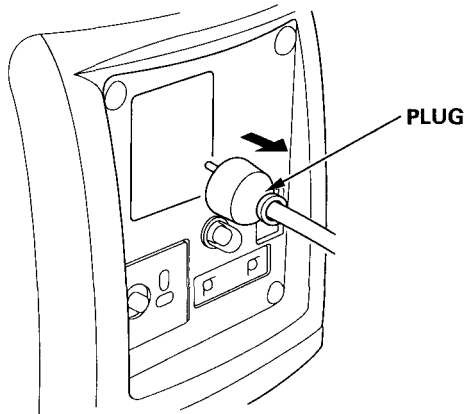

2. Turn the engine switch to the OFF position.

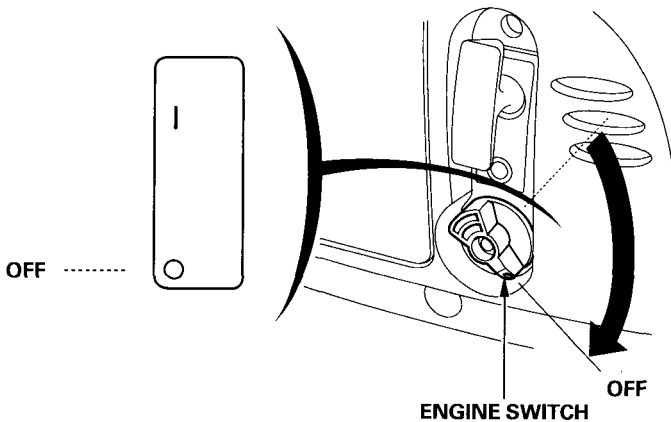

3. Turn the fuel cap vent lever fully counterclockwise to the OFF position.

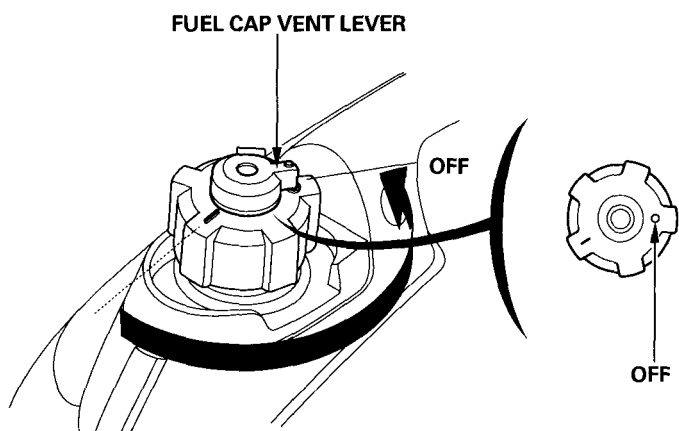

CAUTION:

Be sure the fuel cap vent lever and the engine switch are OFF when stopping, transporting and/or storing the generator.

8. MAINTENANCE

The purpose of the maintenance and adjustment schedule is to keep the generator in the best operating condition. Inspect or service as scheduled in the table below.

▲WARNING

Make sure the engine is off before you begin any maintenance or repairs. This will eliminate several potential hazards:

- **Carbon monoxide poisoning from engine exhaust. Be sure there is adequate ventilation whenever you operate the engine.**
- **Burns from hot parts. Let the engine and exhaust system cool before touching.**
- **Injury from moving parts. Do not run the engine unless instructed to do so.**

The muffler becomes very hot during operation and remains hot for a while after stopping the engine. Be careful not to touch the muffler while it is hot. Let the engine cool before maintenance.

CAUTION:

Use Honda Genuine parts or their equivalent. The use of replacement parts which are not of equivalent quality may damage the generator.

Maintenance Schedule

REGULAR SERVICE PERIOD (3) Performed at every indicated month or operating hour interval, whichever comes first.		Each use	First month or 10 hrs.	Every 3 months or 50 hrs.	Every 6 months or 100 hrs.	Every 2 years or 300 hrs.
ITEM						
Engine oil	Check level	○				
	Change		○		○	
Air cleaner	Check	○				
	Clean			○ (1)		
Spark plug	Check-adjust				○	
	Replace					○
Valve Clearance	Check-adjust					○ (2)
Combustion chamber	Clean	After every 300 hrs (2)				
Fuel tank & filter	Clean	Every year (2)				
Fuel line	Check	Every 2 years (Replace if necessary) (2)				

- NOTE:**
- (1) Service more frequently when used in dusty areas.
 - (2) These items should be serviced by your Honda servicing dealer, unless you have the proper tools and are mechanically proficient. Refer to the Honda shop manual for service procedures.
 - (3) For commercial use, log hours of operation to determine proper maintenance intervals.

1. CHANGING OIL

Drain the oil while the engine is still warm to assure rapid and complete draining.

CAUTION:

Make sure to turn the engine switch and the fuel cap vent lever OFF before draining.

1. Loosen the cover screw and remove the left side maintenance cover.
2. Remove the oil filler cap/dipstick.
3. Drain dirty oil into a container thoroughly.
4. Refill with the recommended oil (see page 14) and check the oil level.
5. Reinstall the oil filler cap/dipstick securely.
6. Reinstall the left side maintenance cover and tighten the cover screw securely.

ENGINE OIL CAPACITY: 0.25 L (0.26 US qt, 0.22 Imp qt)

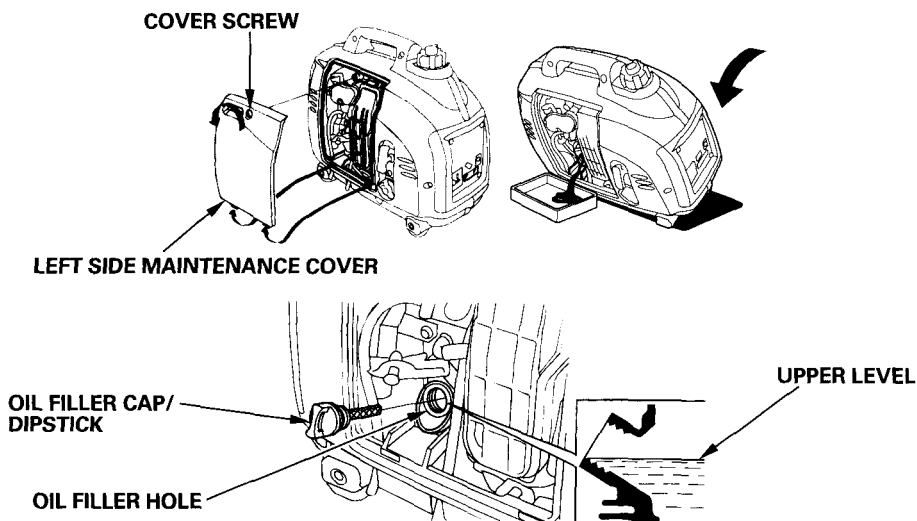

Wash your hands with soap and water after handling used oil.

NOTE:

Please dispose of used motor oil in a manner that is compatible with the environment. We suggest you take it in a sealed container to your local service station for reclamation. Do not throw it in the trash or pour it on the ground.

2. AIR CLEANER SERVICE

A dirty air cleaner will restrict air flow to the carburetor. To prevent carburetor malfunction, service the air cleaner regularly. Service more frequently when operating the generator in extremely dusty areas.

▲WARNING

Do not use gasoline or low flash point solvents for cleaning. They are flammable and explosive under certain conditions.

CAUTION:

Never run the generator without the air cleaner. Rapid engine wear may result.

1. Loosen the cover screw and remove the left side maintenance cover.
2. Press the latch tab on the top of the air cleaner body, and remove the air cleaner cover.
3. Wash the element in a non-flammable or high flash point solvent and dry it thoroughly.
4. Soak the element in clean engine oil and squeeze out the excess oil.
5. Reinstall the air cleaner element and the cover.
6. Reinstall the air cleaner cover by inserting the lower tabs, and the latch tab.
7. Reinstall the left side maintenance cover and tighten the cover screw securely.

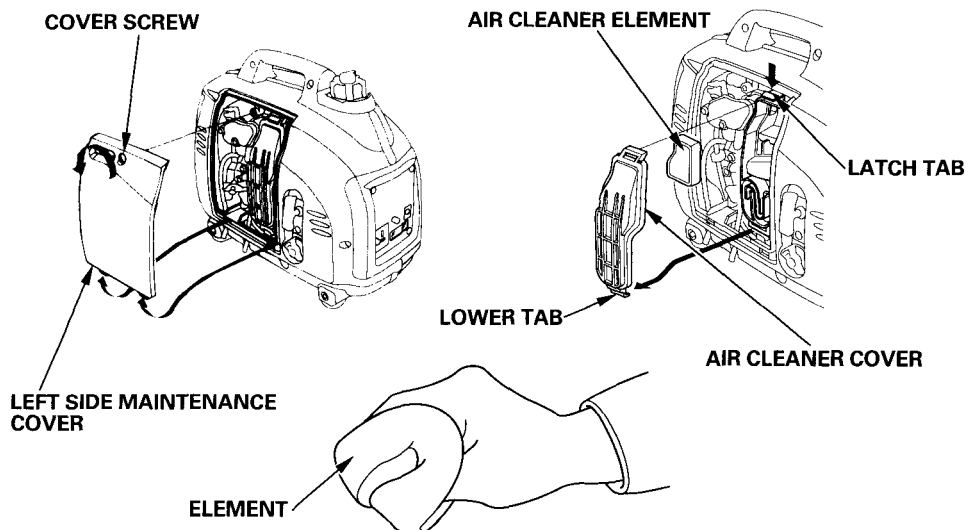

3. SPARK PLUG SERVICE

RECOMMENDED SPARK PLUG: CR4HSB (NGK)
U14FSR-UB (DENSO)

To ensure proper engine operation, the spark plug must be properly gapped and free of deposits.

1. Remove the spark plug maintenance cover.

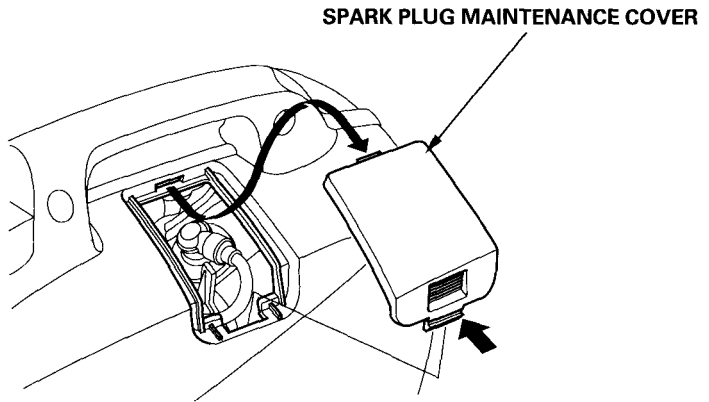

2. Remove the spark plug cap.
3. Clean any dirt from around the spark plug base.
4. Use a spark plug wrench to remove the spark plug.

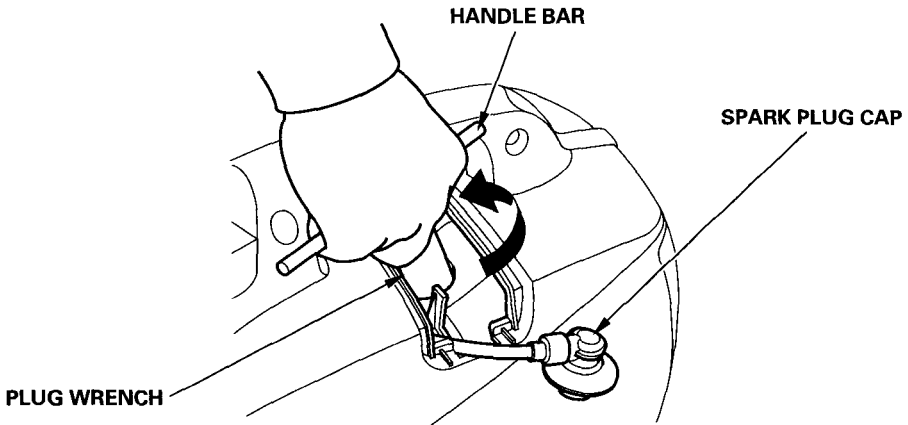

-
5. Visually inspect the spark plug. Discard it if the insulator is cracked, chipped, or fouled. Clean the spark plug with a wire brush if it is to be reused.
 6. Measure the plug gap with a feeler gauge. Correct as necessary by carefully bending the side electrode. The gap should be:
0.6–0.7 mm (0.024–0.028 in)

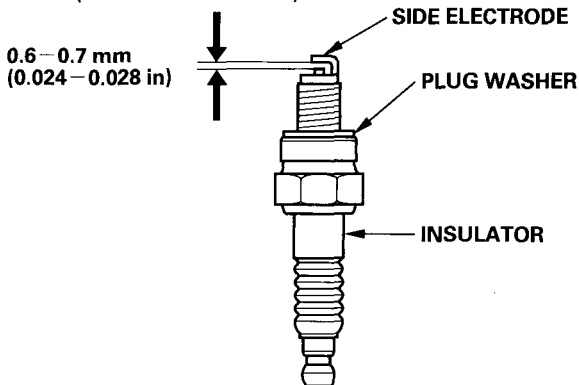

7. Install the spark plug carefully, by hand, to avoid cross-threading.
8. After a new spark plug has been seated by hand, it should be tightened 1/2 turn with a wrench to compress its washer. If a used plug is being reinstalled, it should only require 1/8 to 1/4 turn after being seated.
9. Reinstall the spark plug cap on the spark plug securely.
10. Reinstall the spark plug maintenance cover.

CAUTION:

- The spark plug must be securely tightened. An improperly tightened plug can become very hot and possibly damage the generator.
- Never use a spark plug with an improper heat range.

9. TRANSPORTING/STORAGE

To prevent fuel spillage when transporting or during temporary storage, the generator should be secured upright in its normal operating position, with the engine switch OFF.

The fuel cap vent lever is turned fully counterclockwise to the OFF position.

▲WARNING

When transporting the generator:

- **Do not overfill the tank (there should be no fuel in the filler neck).**
- **Do not operate the generator while it is on a vehicle. Take the generator off the vehicle and use it in a well ventilated place.**
- **Avoid a place exposed to direct sunlight when putting the generator on a vehicle. If the generator is left in an enclosed vehicle for many hours, high temperature inside the vehicle could cause fuel to vaporize resulting in a possible explosion.**
- **Do not drive on a rough road for an extended period with the generator on board. If you must transport the generator on a rough road, drain the fuel from the generator beforehand.**

Before storing the unit for an extended period:

1. Be sure the storage area is free of excessive humidity and dust.
2. Drain the fuel.

▲WARNING

Gasoline is extremely flammable and is explosive under certain conditions. Perform this task in a well ventilated area with the engine stopped. Do not smoke or allow flames or sparks in the area during this procedure.

- a. Unscrew the fuel filler cap and remove the fuel filter.
- b. Drain all gasoline from the fuel tank into an approved gasoline container. We recommend using a commercially available gasoline hand pump. Do not use an electric pump. Reinstall the fuel filter and the fuel filler cap.

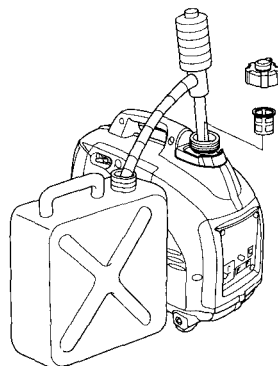

c. Remove the left side maintenance cover.

Turn the engine switch to the ON position, and loosen the carburetor drain screw and drain the gasoline from the carburetor into a suitable container.

d. With the drain screw loosened remove the spark plug cap, and pull the starter grip 3 to 4 times to drain the gasoline from the fuel pump.

e. Turn the engine switch to the OFF position, and tighten the drain screw securely.

f. Reinstall the spark plug cap on the spark plug securely.

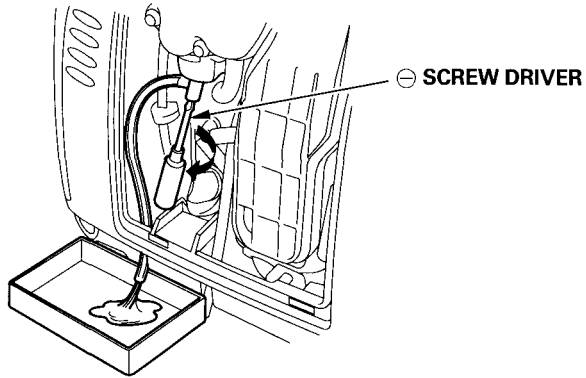

3. Change the engine oil (see page 34).

4. Remove the spark plug and pour about a tablespoon of clean engine oil into the cylinder. Crank the engine several revolutions to distribute the oil, then reinstall the spark plug.

5. Slowly pull the starter grip until resistance is felt. At this point, the piston is coming up on its compression stroke and both the intake and exhaust valves are closed. Storing the engine in this position will help to protect it from internal corrosion.

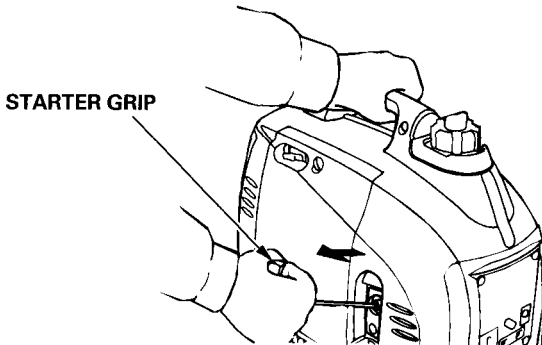

10. TROUBLESHOOTING

When the engine will not start:

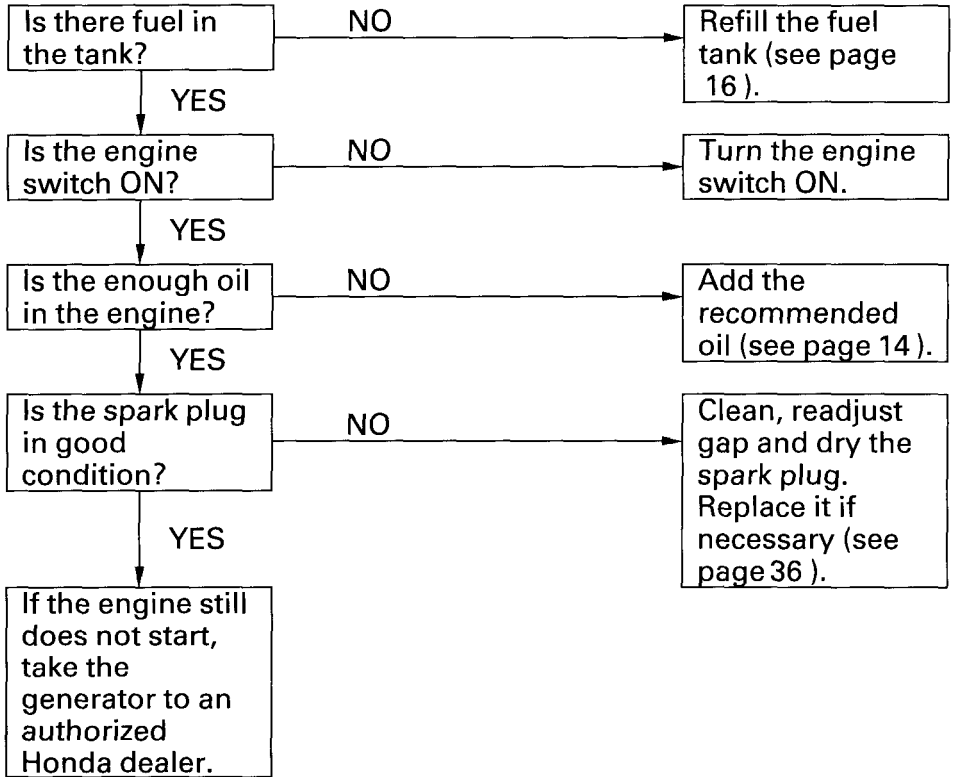

Appliance does not operate:

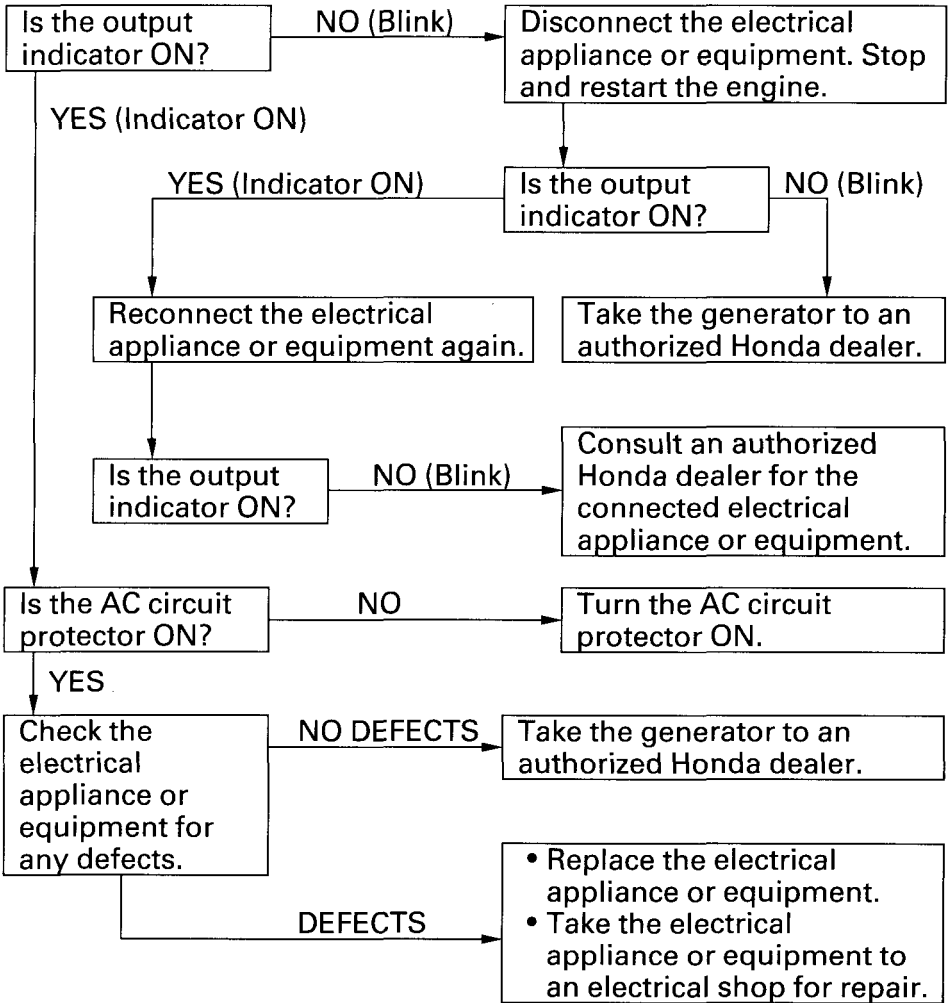

No electricity at the DC receptacle:

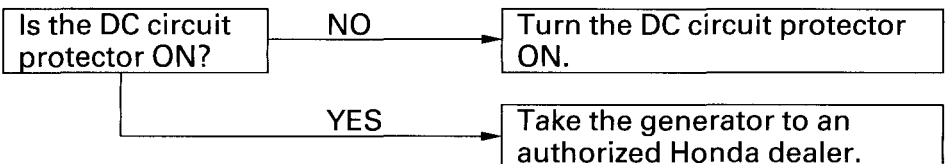

11. SPECIFICATIONS

Dimensions and Weight

Model	EX7
Description code	EZGG
Length	451 mm (17.8 in)
Width	242 mm (9.5 in)
Height	379 mm (14.9 in)
Dry mass (weight)	12.0 kg (26.5 lbs)

Engine

Model	GXH50
Engine type	4-stroke, overhead valve, single cylinder
Displacement	49.4 cm ³ (3.01 cu-in)
Bore × Stroke	41.8 × 36.0 mm (1.64 in × 1.42 in)
Compression ratio	8.0:1
Engine speed	4,500 rpm
Cooling system	Forced air
Ignition system	Full transistor
Oil capacity	0.25 L (0.26 US qt, 0.22 Imp qt)
Fuel tank capacity	2.1 L (0.55 US gal, 0.46 Imp gal)
Spark plug	CR4HSB (NGK) U14FSR-UB (DENSO)

Generator

Model		EX7	
Type		G, GW, B, F, W	U
AC output	Rated voltage (V)	230	240
	Rated frequency (Hz)	50	50
	Rated current (A)	2.6	2.5
	Rated output (kVA)	0.6	
	Maximum output (kVA)	0.7	
DC rated output	Only for charging 12 V automotive batteries. 12 V, 6 A		

Noise

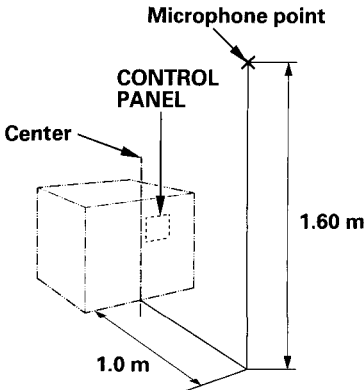
Model	EX7	
Type	G, GW, B, F, W	U
Sound pressure level (LpA) According to 98/37/EC 	68 dB	_____
Guaranteed sound power level (LWA) Tested by 2000/14/EC	83 dB	_____

“the figures quoted are emission levels and are not necessarily safe working levels. Whilst there is a correlation between the emission and exposure levels, this cannot be used reliably to determine whether or not further precautions are required. Factors that influence the actual level of exposure of work-force include the characteristics of the work room, the other sources of noise, etc. i.e. the number of machines and other adjacent processes, and the length of time for which an operator is exposed to the noise. Also the permissible exposure level can vary from country. This information, however, will enable the user of the machine to make a better evaluation of the hazard and risk”.

NOTE:

Specifications are subject to change without notice.

12. WIRING DIAGRAM

AC CP	AC Circuit Protector
AC NF	AC Noise Filter
ACOR	AC Output Receptacle
CPB	Control Panel Block
CyC	Cycloconverter Unit
CyCB	Cycloconverter Block
DCCP	DC Circuit Protector
DCD	DC Diode
DCNF	DC Noise Filter
DCOR	DC Output Receptacle
DCW	DC Winding
EgB	Engine Block
EgG	Engine Ground
ESw	Engine Switch
ExW	Exciter Winding
FrB	Frame Block
FrG	Frame Ground
GB	Generator Block
GT	Ground Terminal
IgC	Ignition Coil
MW	Main Winding
OAL	Oil Alert Indicator
OLSw	Oil Level Switch
PC	Pulser Coil
PL	Output Indicator
SP	Spark Plug
SpU	Spark Unit
SW	Sub Winding

Bl	BLACK
Y	YELLOW
Bu	BLUE
G	GREEN
R	RED
W	WHITE
Br	BROWN
Lg	LIGHT GREEN
Gr	GRAY
Lg	LIGHT BLUE
O	ORANGE
P	PINK

ENGINE SWITCH

	G	Bl
OFF	○	○
ON		

U type

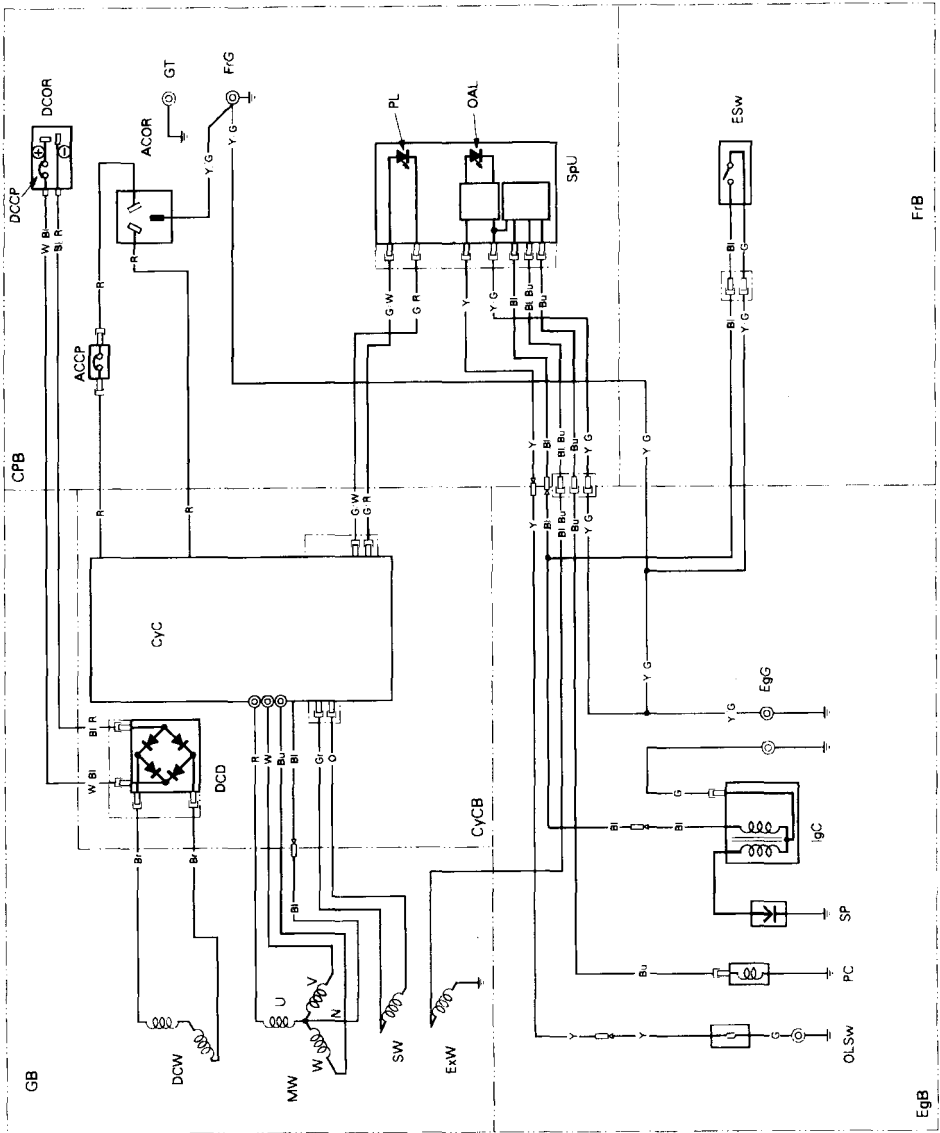

RECEPTACLE

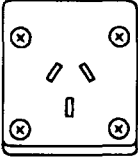
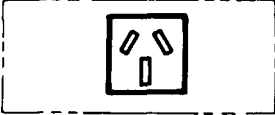
Shape		Type
		U

13. MAJOR Honda DISTRIBUTOR ADDRESSES

For further information, please contact Honda Customer Information Centre at the following address or telephone number:

AUSTRALIA

**Honda Australia Motorcycle
and Power Equipment Pty. Ltd**

1954-1956 Hume Highway

Campbellfield Victoria 3061

Tel. : (03) 9270 1111

Fax : (03) 9270 1133

HONDA
The Power of Dreams

36ZT3710
00X36-ZT3-7100

© Honda Motor Co., Ltd. 2008
EN 英 仏 独 西 中 (HC) 800.2008.10
Printed in Japan