

HONDA

GD321 • GD411

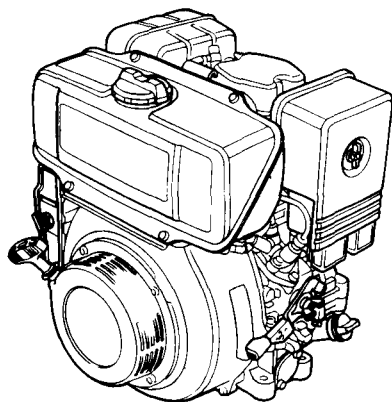

OWNER'S MANUAL



© HONDA MOTOR CO., LTD. 1994

32ZJ8611
00X32-ZJ8-6110

—1—

Ⓜ Ⓢ Ⓟ Ⓜ Ⓟ 10009804

Thank you for purchasing a Honda engine.

This manual covers operation and maintenance of GD321 and GD411 diesel engines. All information in this publication is based on the latest product information available at the time of printing.

Honda Motor Co., Ltd. reserves the right to make changes at any time without notice and without incurring any obligation.

No part of this publication may be reproduced without written permission.

This manual should be considered a permanent part of the diesel engine and should remain with the diesel engine if it is resold.

Pay special attention to statements preceded by the following words:

▲WARNING Indicates a strong possibility of severe personal injury or death if instructions are not followed.

CAUTION: Indicates a possibility of equipment or property damage if instructions are not followed.

NOTE: Gives helpful information.

If a problem should arise, or if you have any questions about your engine, consult an authorized Honda dealer.

▲WARNING Honda engines are designed to give safe and dependable service if operated according to instructions. Read and understand the Owner's Manual before operating the engine. Failure to do so could result in personal injury or equipment damage.

NOTE: If you purchased the engine separately and you plan to use it for some particular application, be sure to follow HONDA's recommended conditions. For details, consult with your authorized Honda engine dealer.

—2—

1 SAFETY INSTRUCTIONS

⚠ WARNING

To ensure safe operation —



Honda engine is designed to give safe and dependable service if operated according to instructions. Read and understand the Owner's Manual before operating the engine. Failure to do so could result in personal injury or equipment damage.

- Honda engines are designed to give safe and dependable service if operated according to instructions. Read and understand this Owner's Manual before operating the engine. Failure to do so could result in personal injury or equipment damage.
- To prevent fire hazards and to provide adequate ventilation, keep the engine at least 1 meter (3 feet) away from buildings and other equipment during operation. Do not place flammable objects close to the engine.
- Children and pets must be kept away from the area of operation due to a equipment the engine may be used to operate.
- Know how to stop the engine quickly, and understand the operation of all controls. Never permit anyone to operate the engine without proper instructions.
- Diesel fuel is flammable and is under certain conditions.
- Refuel in a well-ventilated area with the engine stopped. Do not smoke or allow flames or sparks in the refueling area or where diesel fuel is stored.
- Do not overfill the fuel tank. After refueling, make sure the tank cap is closed properly and securely.
- Be careful not to spill fuel when refueling. Fuel vapor or spilled fuel may ignite. If any fuel is spilled, make sure the area is dry before starting the engine.
- Never run the engine in an enclosed or confined area. Exhaust contains poisonous gas; exposure may cause loss of consciousness and may lead to death.

SAFETY INSTRUCTIONS

⚠ WARNING

To ensure safe operation —

- The muffler becomes very hot during operation and remains hot for a while after stopping the engine. Be careful not to touch the muffler or exhaust pipe while it is hot. To avoid severe burns or fire hazards, let the engine cool before transporting it or storing it indoors.
- Do NOT use gasoline, benzine or any other fuel oils.
- Place on a level and stable surface for use.
(The levelness must be within 20 degrees in all the horizontal directions.)
- Do not remove the sealed engine components. They are critical items.

SAFETY LABEL LOCATION

This label warns you of potential hazards that can cause serious injury. Read it carefully.

If the label comes off or becomes hard to read, contact your Honda dealer for replacement.

READ OWNER'S
MANUAL

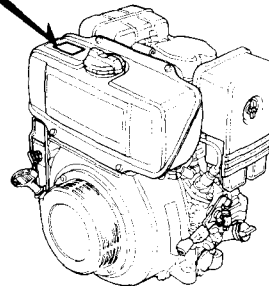

2 COMPONENT IDENTIFICATION

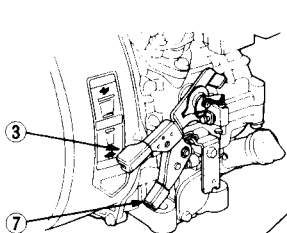

(Dual lever type)

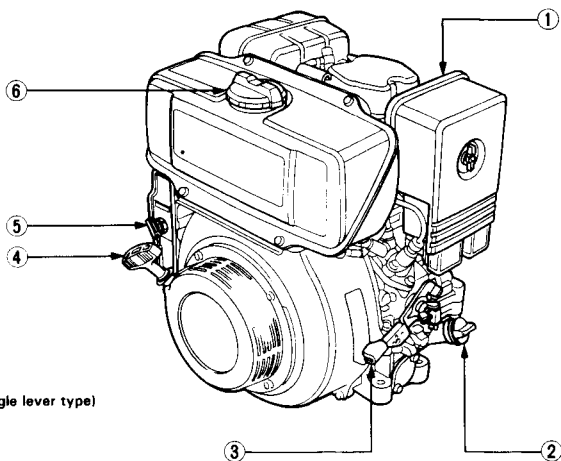
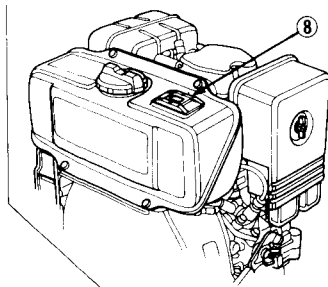

(Single lever type)

- (1) AIR CLEANER
- (2) OIL FILLER CAP
- (3) FUEL TANK CAP
- (4) RECOIL STARTER

- (5) STARTER SWITCH
(Electric starter type only)
- (6) FUEL TANK CAP
- (7) STOP LEVER
- (8) FUEL GAUGE (Equipped type only)

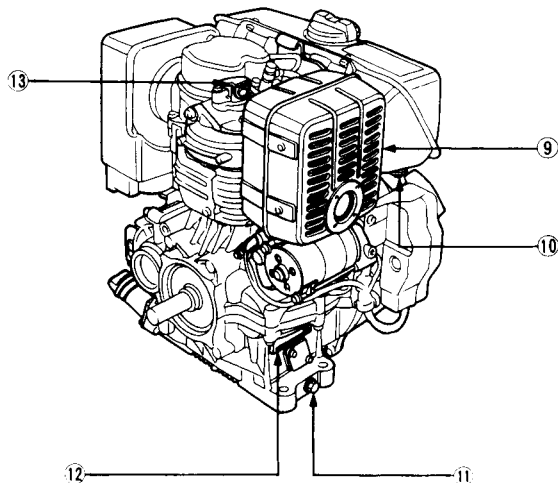

- (9) MUFFLER
- (10) WATER DRAIN BOLT
- (11) ENGINE OIL DRAIN PLUG
- (12) SERIAL NUMBER AND ENGINE TYPE

- (13) DECOMPRESSION LEVER
(Electric starter type only)
- (14) DECOMPRESSION LEVER
(Recoil starter and oil alert system
equipped type only)

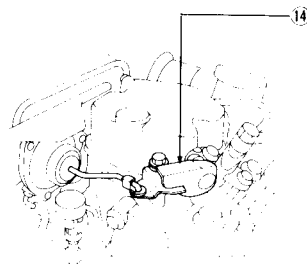

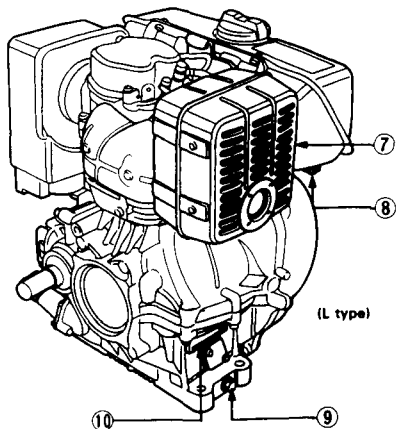
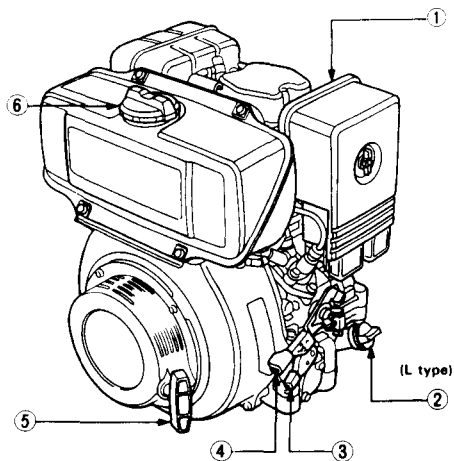

- (1) AIR CLEANER
- (2) OIL FILLER CAP
- (3) STOP LEVER
- (4) ENGINE SPEED CONTROL LEVER
- (5) RECOIL STARTER
- (6) FUEL TANK CAP

- (7) MUFFLER
- (8) WATER DRAIN BOLT
- (9) ENGINE OIL DRAIN PLUG
- (10) SERIAL NUMBER AND ENGINE TYPE

Starter Switch (electric starter equipped type only)

Use this switch to "start" and "stop" the electric starter.

NOTE:

- This switch cannot be used to stop the engine.
- During operation, maintain the starter switch at the "RUN" position. When the engine stop, move the starter switch to the "OFF" position.

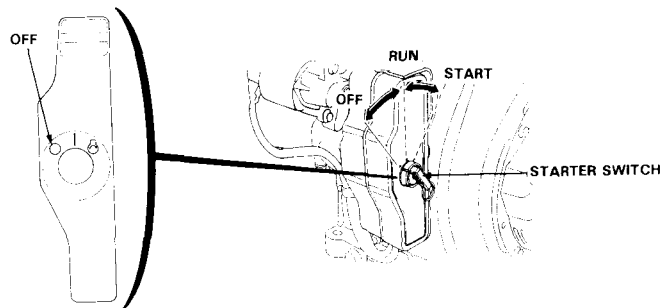

Stop Lever (dual lever type only)

To start the engine, move this lever to the "START" position. To stop it, return the lever to the "STOP" position.

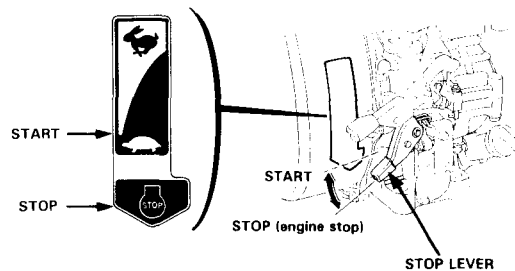

Engine Speed Control Lever

Dual lever type

Position this lever for the desired engine speed.

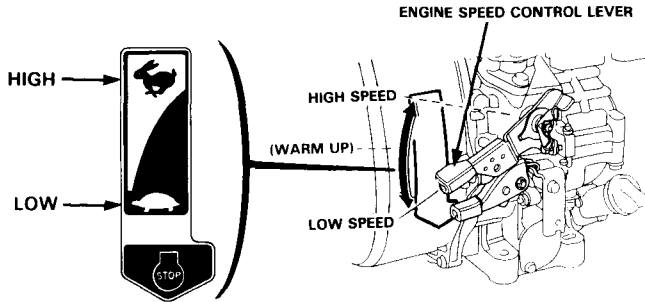

Single lever type

This lever is used to "start" and "stop" the engine as well as to adjust the engine speed.

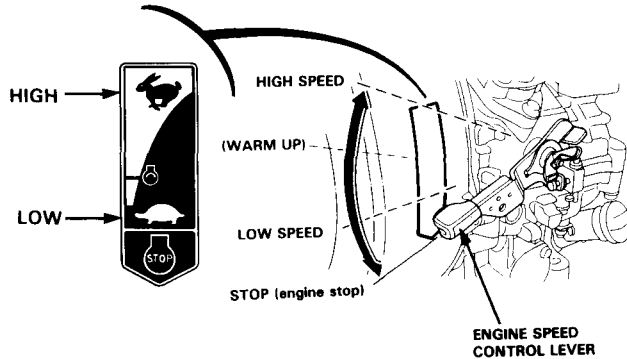

Decompression lever (electric starter type only)

The engine is equipped with a decompression device to aid in cranking the engine with the electric starter. Before starting, move the lever all the way up to decompress the engine. (under the discharged battery) Refer to Page 16 for the usage of the decompression lever.

CAUTION: Under no circumstances should the engine be stopped with the decompression lever.

Failure to follow this precaution could lead to a damaged engine or personal injury.

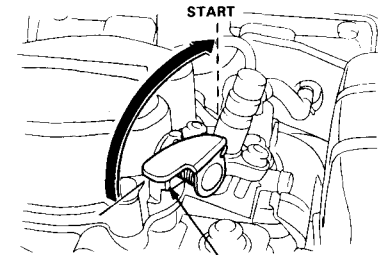

DECOMPRESSION LEVER

Starter grip

Pull the starter grip lightly until resistance is felt, then pull briskly.

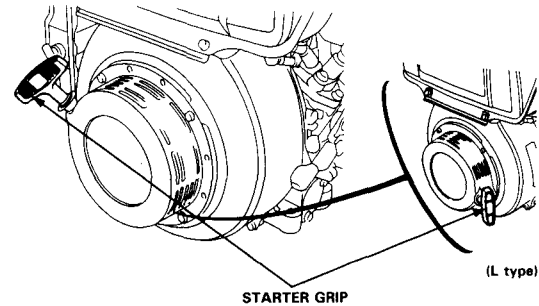

STARTER GRIP

(L type)

3 BATTERY CONNECTIONS (For electric starter)

Use a 12 volt battery with an ampere-hour rating of at least 28 AH.

Connect the battery positive (+) cable to the starter solenoid terminal, as shown.

Connect the battery negative (-) cable to an engine mounting bolt, frame bolt, or other good engine ground connection.

Check the battery cable connections to be sure the cables are tightened and free of corrosion. Remove any corrosion and coat the terminals and cable ends with grease.

Battery cable must be set far from a tail pipe and a muffler.

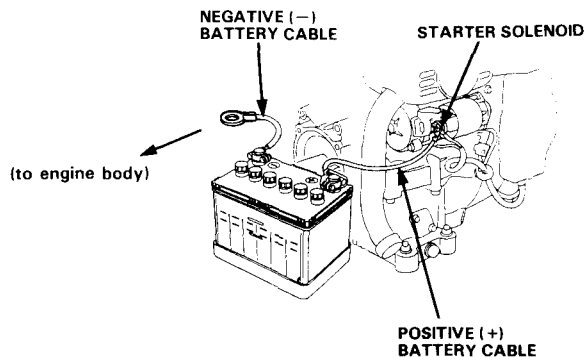

WARNING Batteries produce explosive gases. Keep sparks, flames, and cigarettes away. Always shield the eyes when working near batteries.

4 PRE-OPERATION CHECK

1. Engine oil

CAUTION:

- Engine oil is a major factor affecting engine performance and service life.
- Be sure to check the engine on a level surface with the engine stopped.

SAE 10W-30 diesel oil certified to meet or US automobile manufacturer's requirements for API Service Classification CC or CD (Diesel oils intended for Service CC or CD will show this designation on the container). SAE 10W-30 is recommended for general, all temperature use. Select the appropriate viscosity for the average temperature in your area.

1. Remove the oil filler cap and wipe the dipstick clean.
2. Check the oil level by inserting the dipstick in the filler neck without screwing it in.
3. If the level is low, add the oil to the lower edge of filler neck.

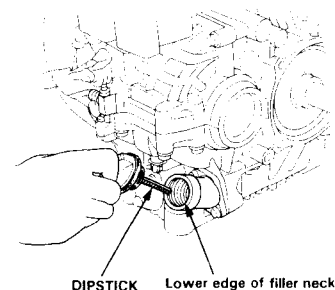
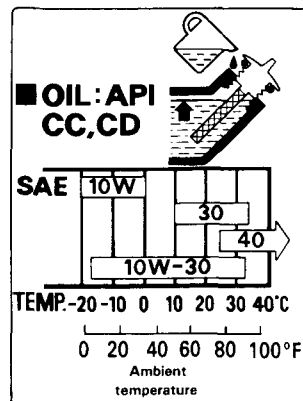

2. Fuel

Remove the fuel cap and check the fuel level. Refill the tank if the fuel level is low.

- Use only clear high-quality fuel.
- Any diesel fuel can be used that conforms with the minimum requirements of one of the following specifications:
The figures "BS2869 A1/A2" and "DIN51601-DK" are for North America, the figures "ASTM D 957-1-D/2-D" and "CAN CGSB-3.6 A/AA" are for EC and General.
- In the winter, use the diesel fuel which are specially prepared for cold weather.

Do not use fouled or mixed diesel fuel.

Avoid getting dirt, dust or water in the fuel tank.

After refueling, be sure to tighten the fuel tank cap firmly.

▲ WARNING

- Diesel fuel oil is flammable and is under certain conditions. Refuel in a well ventilated area with the engine stopped.
- Do not smoke or allow flames or sparks in the area where the engine is refueled or where diesel fuel is stored.
- Do not overfill the tank, and make sure the filler cap is securely closed after refueling.
- Be careful not to spill fuel when refueling or spilled fuel vapor may ignite. If any fuel is spilled, make sure the area is dry before starting the engine.
- Use diesel fuel only. Do not use gasoline, benzene, kerosene or any other fuel oils.

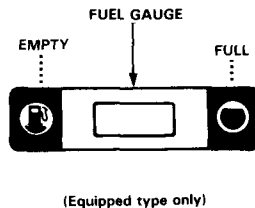
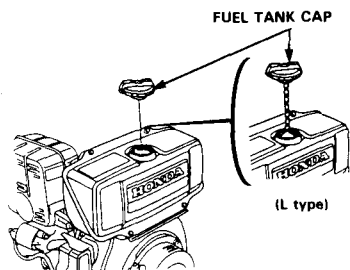

3. Air cleaner

CAUTION: Never run the engine without the air cleaner. Rapid engine wear will result.

1. Check the air cleaner element to be sure they are clean and in good condition.
Clean or replace the elements if necessary (p. 26-27).
2. Check the cyclone housing, and clean it if it is clogged or excessively dirty (p. 26-27).
3. Be sure to tighten up wing nuts after the inspection.

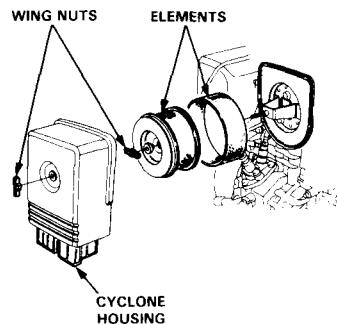

5 STARTING THE ENGINE

Starting the engine

⚠ WARNING Exhaust gas contains poisonous gas. Avoid inhalation of exhaust gases. Never run the engine in a closed garage or confined area.

• With recoil starter

1. (Dual lever type)

- a. Move the stop lever to the "START" position. (Keep moving up until it comes to a stop).

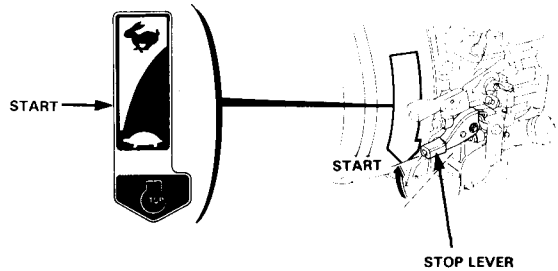

(Single lever type)

- b. Set the engine speed control lever to the "START" position marked "⊖".

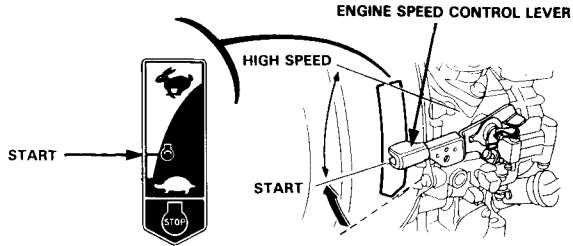

2. Pull the starter grip lightly until resistance is felt, then return it to the original position.

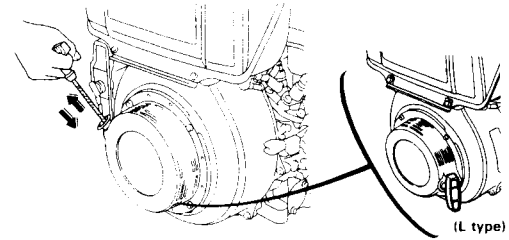

- Pull up on the decompression lever all the way until it will no longer go. (emergent usage)
 - * This operation is not required for the oil alert unit.

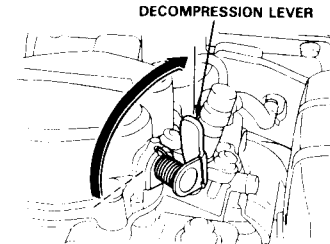

3. Again grasp the starter grip with hand and pull it up with a jerk. (The decompression lever type will automatically reset.)

NOTE: Repeat the steps 2 and 3 if the engine does not start. When the engine is cold, set the control lever to the warm up position (in the middle of HIGH SPEED and LOW SPEED) for about 3 minutes, in order to warm it up to the operating temperature, after starting.

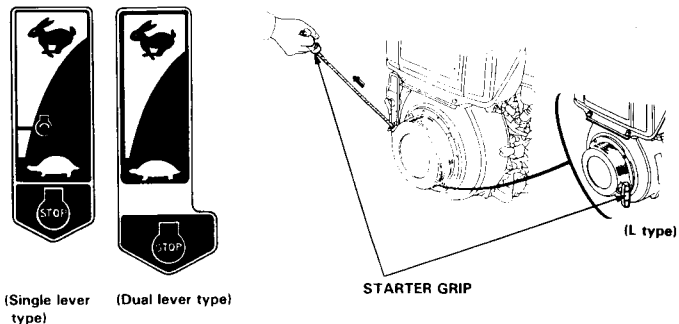

• With electric starter

1. (Dual lever type)
 - a. Move the stop lever to the "START" position (Keep moving up until it comes to a stop).

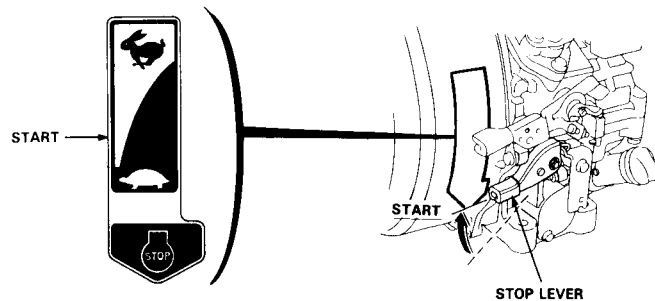

(Single lever type)

- b. Set the engine speed control lever to the "START" position marked "⊖".

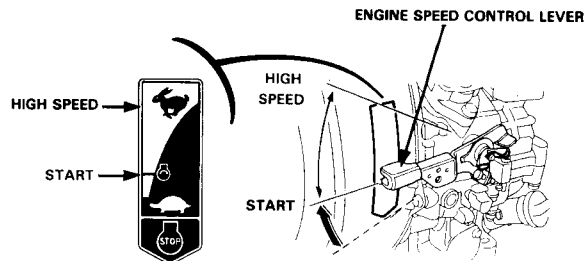

CAUTION:

- Do not allow the starter grip to snap back against the engine. Return it gently to prevent damage to the starter.
- During operation, keep hands off the starter grip, or some engine trouble could turn up.

4. Position the engine speed control lever for the desired engine speed.

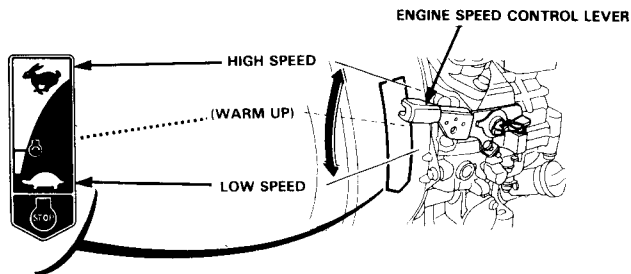

- Turn the starter switch to the "START" position.
Release the switch when the engine starts. It will be returned to the "RUN" position automatically.

NOTE: Do not use the electric starter for more than 5 seconds at a time. If the engine fails to start, release the switch and wait 10 seconds before operating the starter again.

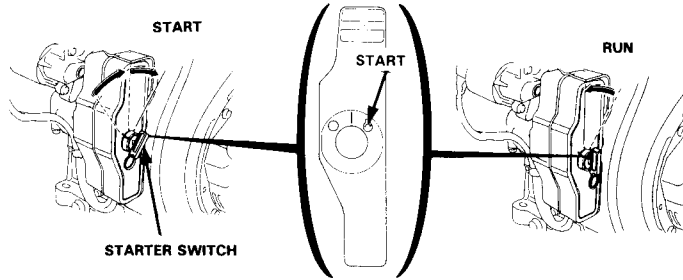

- Position the engine speed control lever for the desired speed.

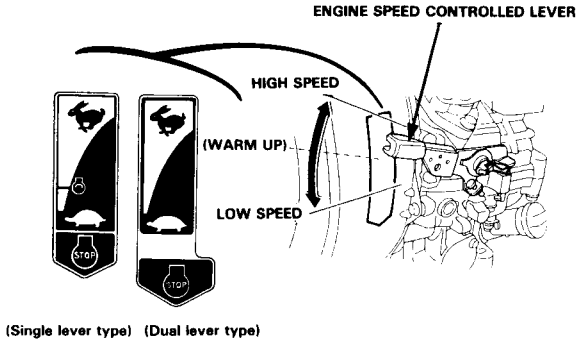

NOTE: When the engine is cold, set the control lever to the warm up position (in the middle of HIGH SPEED and LOW SPEED) for about 3 minutes, in order to warm it up to the operating temperature, after starting.

The engine can be started with the recoil starter if the engine cannot be started electrically due to low or dead battery (see page 15-17 for starting with recoil starter).

Oil Alert System (Recoil Starter and Oil Alert System Equipped Type Only)

The Oil Alert system is designed to prevent engine damage caused by an insufficient amount of oil in the crankcase.

Before the oil level in the crankcase falls below a safe limit, the decompression lever will spring up and the Oil Alert system will automatically shut down the engine.

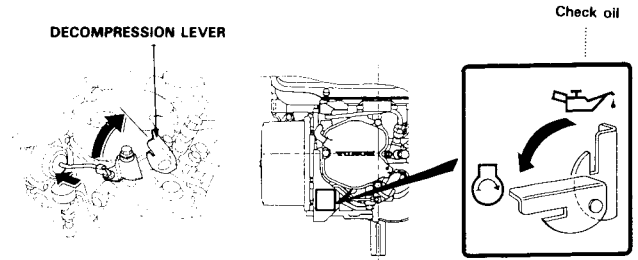

If the engine stops and will not restart, check the engine oil level (p.12) before troubleshooting in other areas.

To restart the engine, depress the decompression lever and follow the procedure described in STARTING THE ENGINE (p.15).

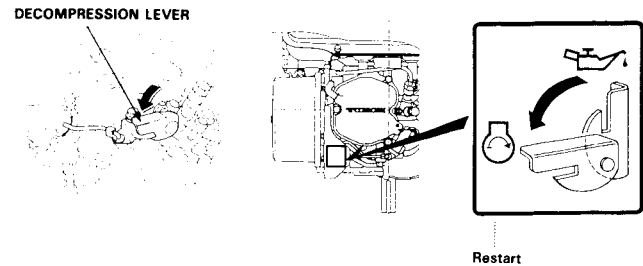

6 STOPPING THE ENGINE

Stopping the engine

1. (Dual lever type)
 - a. Move the stop lever to the "STOP" position.
- (Single lever type)
 - b. Move the engine speed control lever to the STOP position.

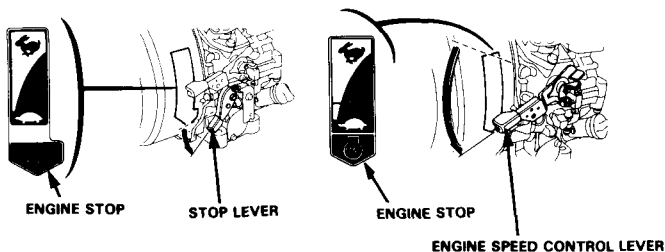

a. Dual lever type

b. Single type

2. (With electric starter)
Move the starter switch to the "OFF" position.

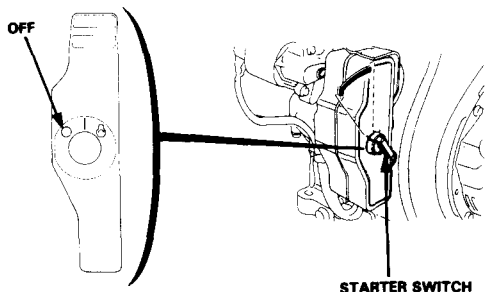

CAUTION: Never stop the engine by operating the decompression lever.

7 MAINTENANCE

- Be sure to check the engine on a level surface with the engine stopped. Periodic maintenance and adjustment is necessary to keep the engine in good operating condition. Perform the service and inspection scheduled in the following table.

▲WARNING Shut off the engine before performing any maintenance. If the engine must be run, make sure the area is well ventilated. The exhaust contains poisonous carbon monoxide gas; exposure can cause loss of consciousness and may lead to death.

CAUTION: Use only genuine HONDA parts or their equivalent. The use of replacement parts which are not of equivalent quality may damage the engine.

ITEM	REGULAR SERVICE PERIOD Perform at every indicated month or operating hour interval, whichever comes first.		EACH USE	FIRST MONTH OR 20 HRS	EVERY 3 MONTHS OR 50 HRS	EVERY 6 MONTHS OR 100 HRS	EVERY YEAR OR 300 HRS	EVERY 2 YEARS OR 500 HRS	EVERY 3 YEARS OR 1000 HRS	REMARKS
	Check level	Change								
Engine oil	Check level	Change	○	○		○				
Engine oil filter	Clean					○				
Air cleaner (Dry type)	Check	Clean	○			○ (1)				(3)
Air cleaner (Wet type)	Check	Clean (Foam element only) Change	○			○ (1)				(4)
Muffler screen	Check	Clean	○			○				
Spark arrester	Clean					○				(5)

- NOTE:** (1) Service more frequently when used in dusty areas.
 (2) These items should be serviced by an authorized Honda dealer, unless the owner has the proper tools and is mechanically proficient. See the Honda Shop Manual.
 (3) The color of paper element is green.
 (4) The color of paper element is red. Also, it is marked with "Wet".
 (5) Equipped type only.

ITEM	REGULAR SERVICE PERIOD Perform at every indicated month or operating hour interval, whichever comes first.	EACH USE	FIRST MONTH OR 20 HRS	EVERY 3 MONTHS OR 50 HRS	EVERY 6 MONTHS OR 100 HRS	EVERY YEAR OR 300 HRS	EVERY 2 YEARS OR 500 HRS	EVERY 3 YEARS OR 1000 HRS	REMARKS
Fuel filter	Change							○ (2)	
Injection nozzle	Check						○ (2)		
Fuel tank (Water drain)	Check Clean			○			○ (2)		
Fuel line	Check (Replace if necessary)								Every 2 years
Combustion chamber, valves and piston rings	Clean-Lap							○ (2)	
Valve clearance	Check-Adjust					○ (2)			
All fasteners (for tightness): Cylinder head bolts, fuel system etc.	Check- Retighten						○ (2)		

- NOTE: (1) Service more frequently when used in dusty areas.
(2) These items should be serviced by an authorized Honda dealer, unless the owner has the proper tools and is mechanically proficient. See the Honda Shop Manual.
(3) The color of paper element is green.
(4) The color of paper element is red. Also, it is marked with "Wet".
(5) Equipped type only.

1. Oil change

Drain the oil while the engine is still warm to assure rapid and complete draining.

1. Remove the oil filler cap and drain plug to drain the oil.
2. Install the drain plug and tighten it securely.
3. Refill with the diesel oil (see page 12) and check the oil level.
4. Install the oil filler cap.

**ENGINE OIL CAPACITY: GD321 1.15 ℓ (1.22 US qt)
GD411 1.25 ℓ (1.32 US qt)**

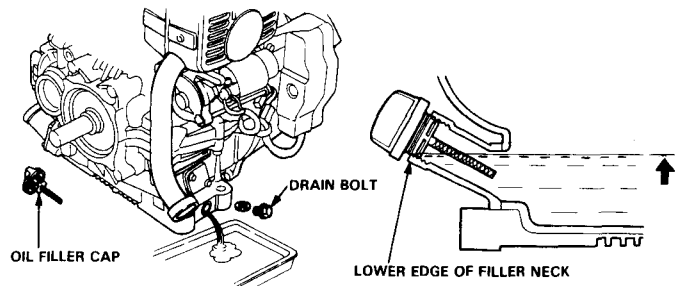

CAUTION: Used motor oil may cause skin cancer if repeatedly left in contact with the skin for prolonged periods. Although this is unlikely unless you handle used oil on a daily basis, it is still advisable to thoroughly wash your hands with soap and water as soon as possible after handling used oil.

NOTE: Please dispose of used motor oil in a manner that is compatible with the environment. Do not throw it in the trash or pour it on the ground.

2. Engine oil filter service

Clogged or restricted oil filter can cause serious engine damage. Oil filter servicing is related to the quality of oil used, and the severity of service. It is recommended that the filter be checked and serviced at intervals, or oftener if necessary, indicated immediately below.

(Cleaning)

1. Drain oil from the engine (see page 24).
2. Remove the oil filter from the engine by removing the two 6 mm bolts.
3. Wash the filter in nonflammable or high flash point solvent. Allow the filter to dry thoroughly.
4. Reinstall the filter and filter cover and screw with the two 6 mm bolts.
5. Tighten the bolts securely.
6. Fill the crankcase to the proper level with the recommended oil.

NOTE:

- Take care not to damage the filter mesh when servicing the filter.
- Replace the filter with a new one if there are holes or tears in the filter mesh.

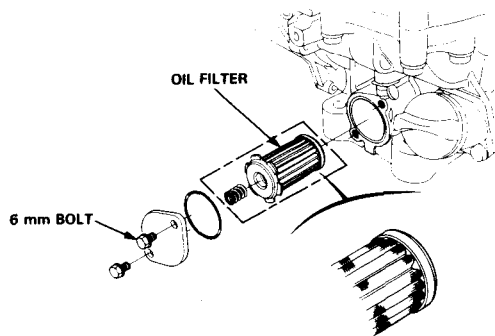

3. Air cleaner (Dry type)

1. Remove the wing nut and the air cleaner cover. Remove the elements and separate them. Carefully check both elements for holes or tears and replace if damaged.
2. Foam element: Wash the element in a solution of household detergent and warm water, then rinse thoroughly, or wash in nonflammable or high flash point solvent. Allow the element to dry thoroughly. Soak the element in clean engine oil and squeeze out the excess oil. The engine will smoke during initial start-up if too much oil is left in the foam.
3. Paper element: Tap the element lightly several times on a hard surface to remove excess dirt, or blow compressed air through the filter from the inside out. Never try to brush the dirt off; brushing will force dirt into the fibers. Replace the paper element if it is excessively dirty.
4. Cyclone Housing: Remove the three special pan head screws, remove the housing, and wash the components with water. Dry the components thoroughly, and carefully reassemble them.

CAUTION: Be careful to install the air guide as shown.

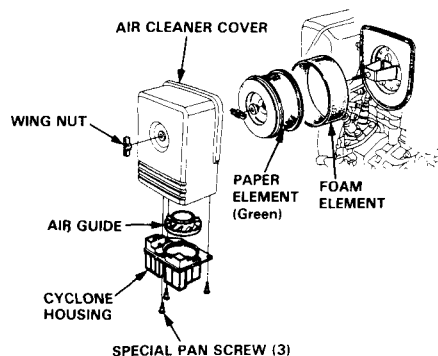

(Wet type)

1. Remove the wing nut and the air cleaner cover. Remove the elements and separate them. Carefully check both elements for holes or tears and replace if damaged.
2. Foam element: Clean at every 100 hours of operation or at every 6 months.
Replace both air cleaner grommet and elements at every 300 hours of operation or at every one year. Wash the element in a solution of household detergent and warm water, then rinse thoroughly, or wash in nonflammable or high flash point solvent. Allow the element to dry thoroughly.
Soak the element in clean engine oil and squeeze out the excess oil. The engine will smoke during initial start-up if too much oil is left in the foam.
3. Paper element: Replace at every 300 hours of operation or at every one year together with air cleaner grommet and elements.
4. Cyclone Housing: Remove the three special pan head screws, remove the housing, and wash the components with water. Dry the components thoroughly, and carefully reassemble them.

CAUTION: Be careful to install the air guide as shown.

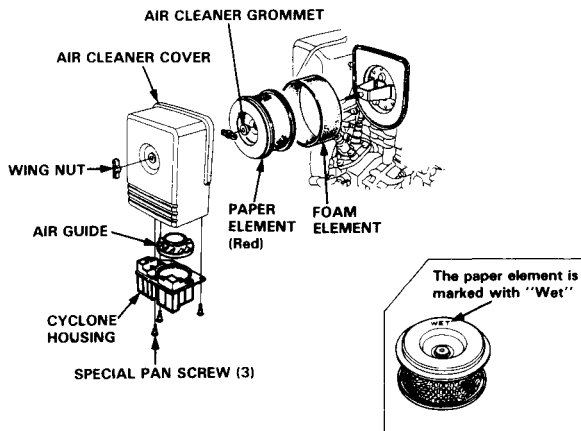

4. Draining water from the fuel tank

It is important that water in the fuel tank be drained regularly. Failure to drain water from the fuel tank regularly can lead to engine malfunction.

(Draining)

1. Loosen the water drain bolt about 2-3 turns to uncover the water drain hole.
2. Continue to drain water through the water drain hole until fuel starts to flow out of the drain hole.
3. Tighten the drain bolt securely.

CAUTION: Do not turn out the drain bolt more than necessary to uncover the water drain hole provided in the bottom of the fuel tank.

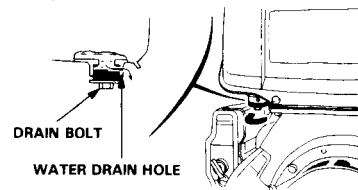

5. Muffler screen maintenance

▲WARNING The muffler becomes very hot during operation and remains hot for a while after the engine stops. Be careful not to touch the muffler while it is hot. Allow it to cool before proceeding.

CAUTION: The muffler screen must be serviced every 100 hours of operation to maintain its efficiency.

1. Loosen the screw bolt from the muffler band. Remove the muffler screen. Be careful not to damage the muffler screen.
 2. Use a wire brush to remove carbon deposits from the muffler screen.
- NOTE: Inspect the muffler screen, and replace it if the screen is broken or torn.
3. Reinstall all parts in the reverse order of removal.

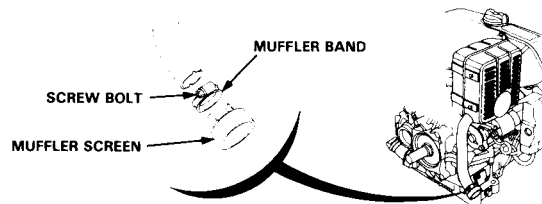

6. Spark arrester maintenance (Equipped type only)

▲WARNING The muffler becomes very hot during operation and remains hot for a while after the engine stops. Be careful not to touch the muffler while it is hot. Allow it to cool before proceeding.

The spark arrester must be serviced every 100 hours to maintain its efficiency.

1. Remove two flange bolts and detach exhaust pipe protector. Then, remove two flange nuts, one bolt, and then the muffler.

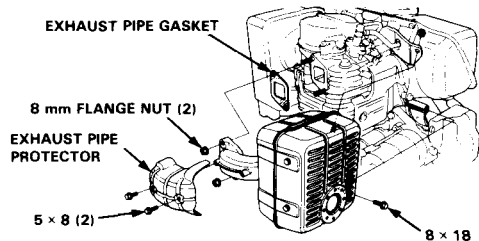

2. Remove three flange nuts and detach the exhaust pipe.
3. Remove the spark arrester from the muffler.
4. Use a wire brush to remove carbon deposits from the spark arrester screen.

NOTE: Inspect the spark arrester screen for holes or tears. Replace it if it is damaged.

5. Reinstall all parts in the reverse order of removal.

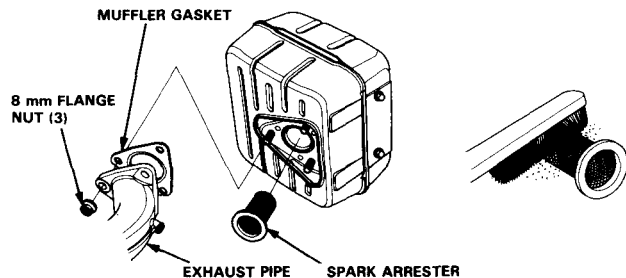

8 TRANSPORTING/STORAGE

▲WARNING Fuel vapor or spilled fuel may ignite.

Before storing the unit for an extended period;

1. Be sure the storage area is free of excessive humidity and dust.
2. Drain the fuel...
Drain fuel from the fuel tank by removing the drain bolt at the bottom of fuel tank.

▲WARNING Diesel fuel is extremely flammable and is explosive under certain conditions. Do not smoke or allow flames or sparks in the area.

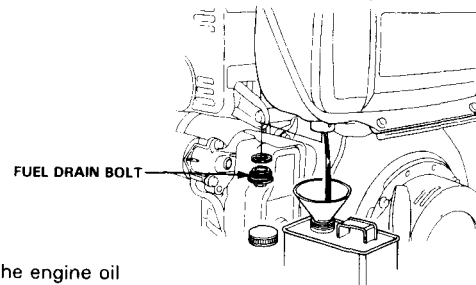

3. Change the engine oil

Without electric starter type:

An electric starter is not provided. Pull up the starter rope carefully, and when it is felt light revert the starter rope to its former position.

Electric starter type:

Pull up the starter rope carefully, and when resistance is felt pull up the decompression lever. When the pressure goes down, revert the lever to its original position, and after confirming that the mark "Δ" of the pulley is on the upside, revert the starter rope to its original position.

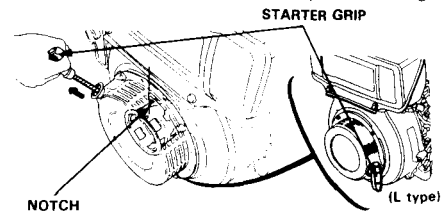

4. Clean the entire engine thoroughly, place a protective cover it, and place in a safe place free of dust and moisture.

9 TROUBLESHOOTING

Engine will not start electrically or with recoil starter:

- Is the stop switch lever in the ON position? (Dual lever type)
- Is the engine speed control lever in the correct position? (Single lever type)
- Is there enough oil in the engine?
 - Does the decompression lever depress? (Recoil starter and oil Alert system equipped type)
- Was the starter grip pulled briskly?

Was the engine started in the correct manner as described in the Owner's Manual?

10 SPECIFICATIONS

The dimensions and weights are for S, Q, P, W, V and B types without electric starter.

Dimensions	GD321				GD411			
	GPAD				GPAC			
	type	S, Q, W, V, P	B	S, Q, P, V, E	B	S, Q, P, V, E	B	
Length	420 mm** (16.5 in)	420 mm (16.5 in)	440 mm** (17.3 in)	440 mm (17.3 in)	405 mm (15.9 in)	445 mm (16.1 in)	405 mm (15.9 in)	445 mm (16.1 in)
Width	405 mm (15.9 in)	445 mm (16.1 in)	470 mm (18.5 in)	490 mm (19.3 in)	470 mm (18.5 in)	490 mm (19.3 in)	470 mm (18.5 in)	490 mm (19.3 in)
Height	470 mm (18.5 in)	470 mm (18.5 in)	470 mm (18.5 in)	490 mm (19.3 in)	470 mm (18.5 in)	490 mm (19.3 in)	470 mm (18.5 in)	490 mm (19.3 in)
Dry weight	48 kg (105.8 lb)	49 kg (110 lb)	54 kg (119 lb)	55 kg (123 lb)	48 kg (105.8 lb)	49 kg (110 lb)	54 kg (119 lb)	55 kg (123 lb)

Engine

Engine type	4-stroke, overhead valve, 1 cylinder diesel							
Displacement [Bore x Stroke]	317 cm ³ (19.3 cu in) [76 x 70 mm (3.0 x 2.8 in)]				411 cm ³ (25.1 cu in) [82 x 78 mm (3.2 x 3.1 in)]			
	5.1 KW/3600 rpm (7 HP/3600 rpm)		4.4 KW/3000 rpm (6.0 HP/3000 rpm)		6.6 KW/3600 rpm (9 HP/3600 rpm)		5.5 KW/3000 rpm (7.5 HP/3000 rpm)	
Max. output	15.7 N·m {1.6 kg·m (11.6 ft·lb)} 2500 rpm		20.6 N·m {2.1 kg·m (15.2 ft·lb)} 2500 rpm		15.7 N·m {1.6 kg·m (11.6 ft·lb)} 2500 rpm		20.6 N·m {2.1 kg·m (15.2 ft·lb)} 2500 rpm	
Engine oil capacity	1.15 ℓ (1.22 US qt)				1.25 ℓ (1.32 US qt)			
Fuel consumption	180 g/psh	190 g/psh ^{*3}	180 g/psh	190 g/psh	180 g/psh	190 g/psh	180 g/psh	190 g/psh
Cooling system	Forced air							
Fuel injection pump	PFRIKX made by ZEXEL							
Fuel used	Diesel fuel							
Engine start system	Recoil starter, Recoil or electric starter							
PTO shaft rotation	Counterclockwise							
Rated output	4.4 KW/3600 rpm (6 HP/3600 rpm)	3.7 KW/3000 rpm (5.1 HP/3000 rpm)	5.9 KW/3600 rpm (8 HP/3600 rpm)	4.7 KW/3000 rpm (6.5 HP/3000 rpm)	4.4 KW/3600 rpm (6 HP/3600 rpm)	3.7 KW/3000 rpm (5.1 HP/3000 rpm)	5.9 KW/3600 rpm (8 HP/3600 rpm)	4.7 KW/3000 rpm (6.5 HP/3000 rpm)
Compression ratio	19 : 1 ^{*5}				18.2 : 1 ^{*4*5}			
Fuel tank capacity	4.6 ℓ (4.9 US qt)							
Injection nozzle	DLA-P made by ZEXEL							
Combustion system	Direct injection system							

NOTE: Specifications are subject to change without notice.

- *1 For B type, max. torque is 15.7 N·m {1.6 kg·m (11.6 ft·lb)} 1800 rpm.
- *2 For B type, max. torque is 19.6 N·m {2.0 kg·m (14.5 ft·lb)} 1800 rpm.
- *3 For B type, fuel consumption is 196 g/psh.
- *4 For B type, compression ratio is 19.4 : 1.
- *5 For north america type, compression ratio is 20 : 1
- *6 For Q type, length is 445, for W type, length is 460, for E type, length is 435, for P type, length is 450 and for V type, length is 465.
- *7 For Q type, length is 465, for P type, length is 465, for E type, length is 450 and for V type, length is 480.

The dimensions and weights are for L type without electric starter.

Dimensions	GD321	GD411
Description code	GPAD	GPAC
Length	420 mm (16.5 in)	435 mm (17.1 in)
Width	405 mm (15.9 in)	405 mm (15.9 in)
Height	470 mm (18.5 in)	490 mm (19.3 in)
Dry weight	50 kg (110 lb)	57 kg (126 lb)

Engine

Engine type	4-stroke, overhead valve, 1 cylinder diesel	
Displacement [Bore x Stroke]	317 cm ³ (19.3 cu in) [76 x 70 mm (3.0 x 2.8 in)]	411 cm ³ (25.1 cu in) [82 x 78 mm (3.2 x 3.1 in)]
	5.0 KW/1800 rpm (6.8 HP/1800 rpm)	6.4 KW/1800 rpm (8.7 HP/1800 rpm)
Max. output	5.0 KW/1800 rpm (6.8 HP/1800 rpm)	6.4 KW/1800 rpm (8.7 HP/1800 rpm)
Max. torque	30.4 N·m {3.1 kg·m (23 ft·lb)} 1250 rpm	40.2 N·m {4.1 kg·m (30 ft·lb)} 1250 rpm
Engine oil capacity	1.15 ℓ (1.22 US qt)	1.25 ℓ (1.32 US qt)
Fuel consumption	190 g/psh	
Cooling system	Forced air	
Fuel injection pump	PFRIKX made by ZEXEL	
Fuel used	Diesel fuel	
Engine start system	Recoil starter, Recoil or electric starter	
PTO shaft rotation	Counterclockwise	
Rated output	4.4 KW/1800 rpm (6 HP/1800 rpm)	5.9 KW/1800 rpm (8 HP/1800 rpm)
Compression ratio	19 : 1	18.2 : 1
Fuel tank capacity	4.6 ℓ (4.9 US qt)	
Injection nozzle	DLA-P made by ZEXEL	
Combustion system	Direct injection system	

NOTE: Specifications are subject to change without notice.